

SHENZHEN ATTEN TECHNOLOGY CO., LTD.

- Soldering Iron
- Soldering Station
- Hot Air Rework Station
- Multi-function Rework System
- Switching DC Power Supply
- Regulated DC Power Supply
- Solder smoke purify machine
- Programmable Power Supply

ATTEN



ST-9003D/ST-1203D/ST-3003D High Frequency Soldering Station User Manual

SHENZHEN ATTEN TECHNOLOGY CO., LTD.

Add: Floor 7 & 8 , Building B, Konka Guangming Technology Center,
No.228 Xingxin Road, Guangming District, Shenzhen 518100, China

Tel: +86 0755-8602 1389 400-998-6633

Web: www.atten.com

Email: sales@atten.com.cn

MADE IN CHINA
CBN036764 (D)

SHENZHEN ATTEN TECHNOLOGY CO., LTD

Content

01. Safety and cautions.....	01
02. Package list and appearance description.....	02
Packing list.....	02
Appearance description.....	02
03. Specification.....	03
Technical parameters.....	03
Packing.....	03
LCD display description.....	03
04. Connection and operation.....	04
Connection.....	04
Boot-up screen.....	05
Working status.....	05
Temperature setting.....	06
Quickly retrieve temperature.....	06
Adjust pre-setting temperature.....	06
05. Menu setting.....	06
Temperature lock function.....	06
Temperature unit exchange.....	07
Temperature calibration.....	07
Auto-standby.....	07
Auto-sleep.....	08
Beep setting.....	08
Password setting.....	08
High temperature mode.....	09
Temperature alarm.....	09
Address setting.....	09
Restore factory setting.....	09
Master-Slave mode setting.....	10
Online device power-on delay setting.....	10
Online device shutdown delay setting.....	11
Vibration switch sensitivity setting.....	12
IR temperature calibration.....	12
Communication function	13
Soldering iron tip and heater accessories.....	13
06. Soldering tip and heater changing.....	13
07. Maintenance.....	16
08. Product warranty.....	17

08/ Product warranty

• Warranty regulations:

- ① The warranty period of this product is calculated from the date of purchase. During the warranty period, under the condition of normal use of this product, if the fault occurs due to the quality problem of the product itself, according to the content of this warranty card, you can enjoy free maintenance serve at the authorized repair place designated by the company (or the company) by presenting the original warranty card. Please keep the proof of purchase and this warranty card, and present them together when maintenance.
- ② During the warranty period, paid maintenance services will be implemented in the following situations:
 - a. Failure to provide a valid warranty card or valid certificate.
 - b. Items such as the date of purchase and the name of the sales unit are not completely filled in or the warranty card is altered.
 - c. Damage caused by failure to operate in accordance with the usage methods and precautions written in the instruction manual.
 - d. Damage caused by natural disasters or force majeure.
 - e. Damage caused by dismantling, repairing or modifying the product without the authorization of the manufacturer.
 - f. Replacement of fragile and consumable parts.
- ③ All items of the warranty card must be filled in completely by the agent or user directly to obtain a 24-month warranty period.
- ④ Please keep this warranty card properly, it will not be reissued if it is lost.
- ⑤ In special circumstances, the two parties shall negotiate and deal with it.
- ⑥ The final interpretation right belongs to our company.

User Notice

The warranty period of this product is valid within 24 months from the date of purchase. For any product quality problem, the company will be responsible for free maintenance with this card and purchase certificate.

Note: When this product is returned to the factory for maintenance, the warranty card must be attached, other wise it will not be repaired for free, thank you for your cooperation (please read the warranty regulations for warranty related instructions)

Product warranty card

Product Model: _____ Product No.: _____

EX-Factory No.: _____ Sold Date: _____

This product test result is qualified and met the technical standard.



Disclaimer

- We will take no responsibility for any personal injury or property damage caused by reasons other than the product quality problem, which may include force majeure (natural disasters, etc.) or personal behavior during the operation of this product.
- This manual is organized, compiled and released by SHENZHEN ATTEN TECHNOLOGY CO., LTD. According to the latest product features. We will not be responsible for further notice of the subsequent improvement of the product and this manual.

07/ Maintenance

Warning

- It should be maintained by qualified electric technician or service personnel specified by original factory to check the fault or clean the machine, turn the power off and allow the unit to cool down to room temperature.
- Before carrying out any cleaning or maintenance work, always make sure that the appliance is disconnected from the mains supply by unplugging the power cord from socket-outlet.

Description	Reason	Guide
Unable to turn on	Fuse unequipped or damaged	Check if the fuse is damaged (if so, please replace the fuse according to the specifications)
	Power cord poor contact	Check power cord connection
	Motherboard burnout	Please contact the local dealer or manufacturer for assistance.
E-1	The heating element is open circuit	Replacement of heating core
E-2	Sensor fault	1.Replacement of heating core 2.Check if the handle and heating element is connected.
E-3	No zero-cross signal	The zero-cross sensor is damaged or the mains frequency is wrong
E-8	Over-temperature protection	The short circuit occurs to the temperature sensor in the heating core; please replace the heating core
E11 (Only for ST-3090D and ST-3300D)	Soldering tip is not installed	turn the power off and allow the unit to cool down to room temperature, please use the accessories from the original factory

● After-sales contact

- If the machine fails, or cannot work normally due to unknown reasons, please contact the local dealer or manufacturer for consultation.
- After-sales service department Tel: 400-998-6633

01/Safety and cautions

- The design of this product (including software) and its accessories are under tutelage of laws. Any action to violate relevant right of our product will be penalized by the law. Please consciously observe relevant local laws in the use of this product.
- **Thank you for purchasing our products Please read this manual carefully and pay attention to warnings and precautions mentioned herein before using this product. Save this booklet for future reference.**

 **warning** Failure to comply with a WARNING may result in serious injury or death.

 **Attention** Failure to comply with a ATTENTION may result in injury to the operator, or damage to the items involved.

- We assume that user have common sense and basic relevant electrical operation knowledge before using this product. Children shall not play with the appliance without supervision.

 **Attention** To avoid damaging to unit and please keep the operating environment safe.

- To avoid electric shock, injury to user or causing fire, please comply with the following items.
- To ensure your safety and avoid damage to the unit, please use parts and accessories that have been approved or recommended by our factory.

Warning

- READ ALL INFORMATION BEFORE USE.
- Power off when not in use or unattended. Place the soldering iron handle the iron stand, This tool must be placed on its stand when not in use.
- Keep this product away from flammable materials. When using, please inform other people in the area near the machine. Please do not touch the machine because of high temperature
- Do not apply to the same place for a long time.
- Be aware that heat may be conducted to combustible materials that are out of sight.
- Do not leave the appliance unattended when it is switched on.
- This appliance is not intended for use by persons (including children) with reduced physical, sensory or mental capabilities, or lack of experience and knowledge, unless they have been given supervision or instruction concerning use of the appliance by a person responsible for their safety.
- Children should be supervised to ensure that they do not play with the appliance.
- Cleaning and user maintenance shall not be made by children without supervision.
- If the supply cord is damaged, it must be replaced by the manufacturer, its service agent or similarly qualified persons in order to avoid a hazard.

Attention

- Before switching on the power supply, ensure that the voltage of the product conforms to the applicable local voltage to avoid permanent damage to the mac
- The soldering process will produce smoke, so make sure the area is well ventilated.
- When the power is on, the tip temperature is between 80°C~600°C/176°F~1112°F, since mishandling may lead to burns or fire.
- Do not use this product if you are inexperienced or have no sufficient necessary knowledge without the guidance of related personnel.
- Do not use this product under wet environment or with wet hands to prevent electric shock.
- To ensure the normal operation of this product's grounded function, make sure that the power supply is well grounded when connecting the machine.
- Before replacing parts or storing the unit, turn the power off and allow the unit to cool down to room temperature.
- Please use the accessories from the original factory when replacing the product parts.
- Do not play or do other similar dangerous actions when using this equipment, because it can easily lead to injury to others or yourself.
- Do not use it for any purpose other than the function of the product, to avoid machine damage or personal injury.
- Do not use it for any purpose other than the function of the product, to avoid machine damage or personal injury.
- Do not modify this product and its accessories, otherwise the original warranty will be invalidated or damage may occur to the product.
- When plugging and unplugging the power cord and handle plug, please hold the plug body and do not pull the cord.
- Do not hit the product or its accessories too hard during the operation; otherwise damage may occur to the product.

02/ Package list and appearance description

• Packing list



High frequency soldering station host *1



Iron stand (include copper cleaning wire ball) *1



Soldering iron handle *1



Ground wire *1



Power cord *1



Hex wrenches*1



User manual *1
Certificate *1

• Appearance description

- ① LCD display
- ② "1", "2", "3" key:
Short press: quickly retrieve the temperature parameters
Long press: save the current temperature parameter
- ③ "▲" / "▼" Adjusting key
- ④ "MENU/ENTER"
Short press: turn on IR temperature calibration function
Long press: enter into the main setting menu interface
- ⑤ Infrared receiver
- ⑥ Soldering iron handle interface
- ⑦ Power switch

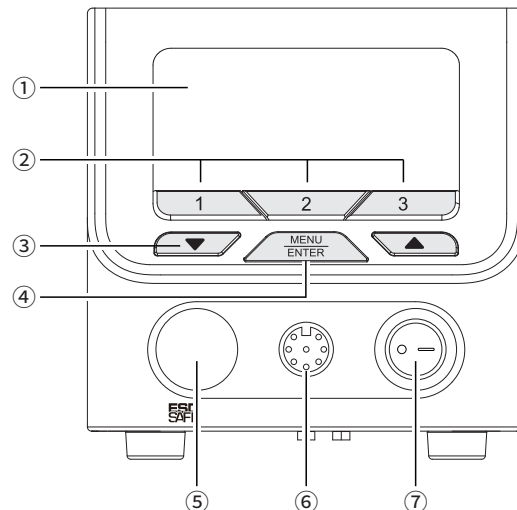

• ST-3003D soldering tip changing:

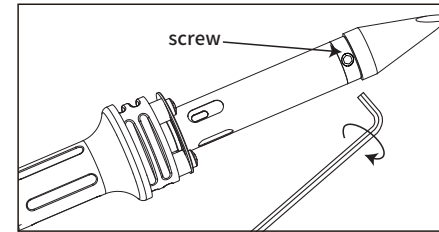

- ① Use a screwdriver to remove the screw.

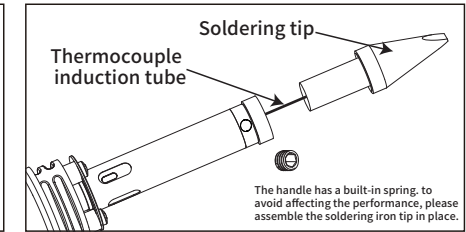

- ② Remove the tip of the soldering iron and replace it with a new one (note: the new tip must be inserted into the thermocouple induction tube and locked with a slotted screw).

• ST-3003D Changing heater:

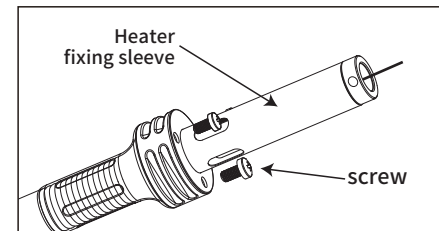

- ① Take out the soldering iron tip first, and then use a Phillips screwdriver to remove the heater fixing sleeve screw.

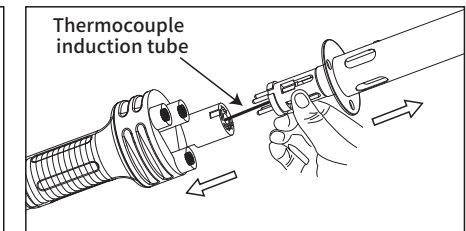

- ② As shown in the figure, pull out the heater about 4cm, and replace it with a new one (Note: the new heater must be inserted into the thermocouple induction tube and installed to the appropriate hole).

• ST-9003D Changing heater:

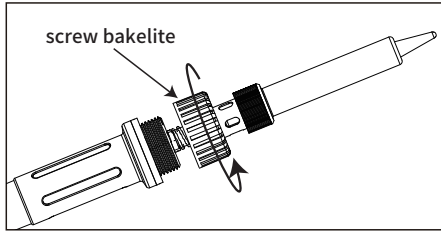

① Remove the screw bakelite as the direction indicated.

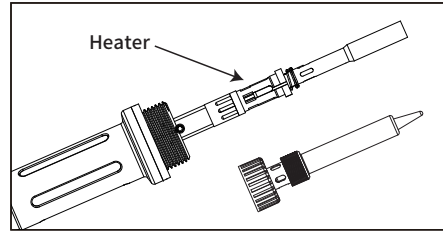

② Remove the sleeve and soldering iron tip, and pull out the heater away 3~4cm.

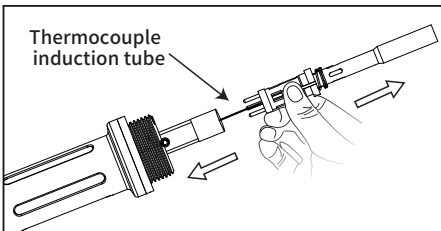

③ Take out the heater and replace it with a new one (Note: the replacement heater must be inserted into the thermocouple induction tube and installed to the appropriate hole).

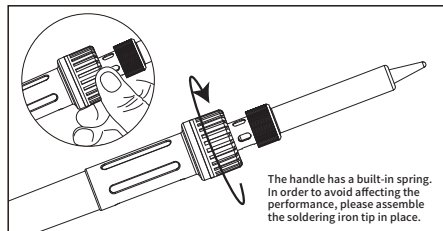

④ Assemble all parts in place according to the disassembly steps and the heater is replaced.

• ST-1203D integrated soldering tip changing:

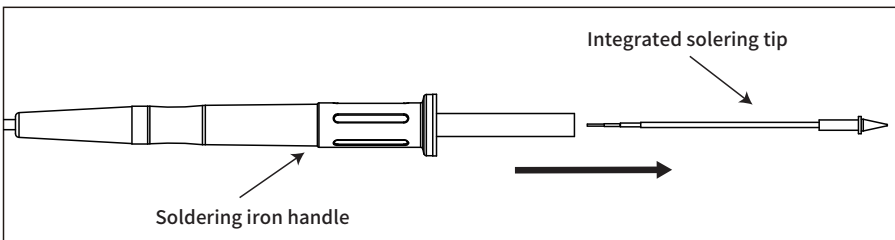

Cut off the power supply of the machine and wait until the heater and handle completely cool to room temperature, take out and replace the integrated soldering tip along the direction of the figure.

03/ Specification

• Technical parameters

High frequency soldering station host:

Model	ST-9003D	ST-1203D	ST-3003D
Rated operating voltage	AC 220-240V~ 50/60Hz / (AC 110-125V~ 60Hz)		
Power	110W (±10)	150W (±10)	320W (±10)
Temperature range	80°C~500°C 176°F~932°F		80°C~600°C 176°F~1112°F
Standby mode	Default 3 minutes (1~60 minutes adjustable)		
Sleep mode	Default 30 minutes (1~60 minutes adjustable)		
Grounded	support		
IR temperature calibration	support		
communication interface	support		
Working conditions	Temperature 0°C~40°C; Relative humidity < 85%RH		
Dimension	200 (L) x125 (W) x120 (H) mm		240(L)x125(W)x120(H) mm
Weight (N.W.)	≈3kg	≈3.3kg	≈2.3Kg

Soldering iron handle:

Model	SP-H090	SP-H120	SP-H300
Power	≥90W	≥120W	≥300W
Soldering tips	T300	T120	T330
Heater	HS-3090H	HS-3120H	HS-3300H
Tip-to-ground impedance	≤2Ω		
Tip-to-ground voltage	≤2mV		
Wire length	120cm		
Dimension	210 (L) x14 (W) x14 (H) mm		210(L)x18(W)x18(H) mm
Weight (N.W.)	≈89g	≈77g	≈120g

• Packing

Model	Inner box package		outer carton package	
ST-9003D	290x260x185mm	G.W: ≈4.16KG	535x305x395mm (4pcs/carton)	G.W: ≈17.5KG
ST-1203D		G.W.: ≈4.46KG		G.W: ≈19KG
ST-3003D	306x276x200mm	G.W: ≈3.28KG	570x320x425mm (4pcs/carton)	G.W: ≈14KG

• LCD display description

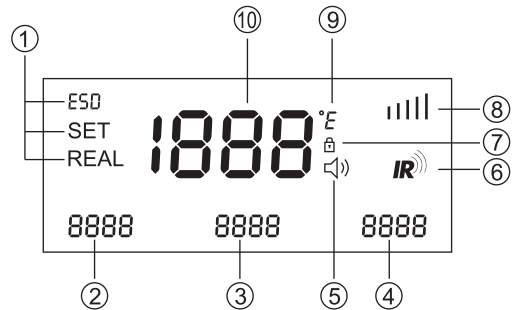

- | | |
|---|--------------------------|
| ① ESD: grounded
SET: setting
REAL: real temperature | ⑤ Beep function ON/OFF |
| ② Show preset temperature 1 | ⑥ IR function turn on |
| ③ Show preset temperature 2 | ⑦ Temperature lock |
| ④ Show preset temperature 3 | ⑧ Show power |
| | ⑨ Temperature unit °C/°F |
| | ⑩ Show temperature |

04/ Connection and operation

• Connection

- ① Plug soldering iron cable end into the front interface and put handle into the stand.
- ② Plug the power cord and ground wire into the behind interface. (Please ensure the power voltage is fit for this product)

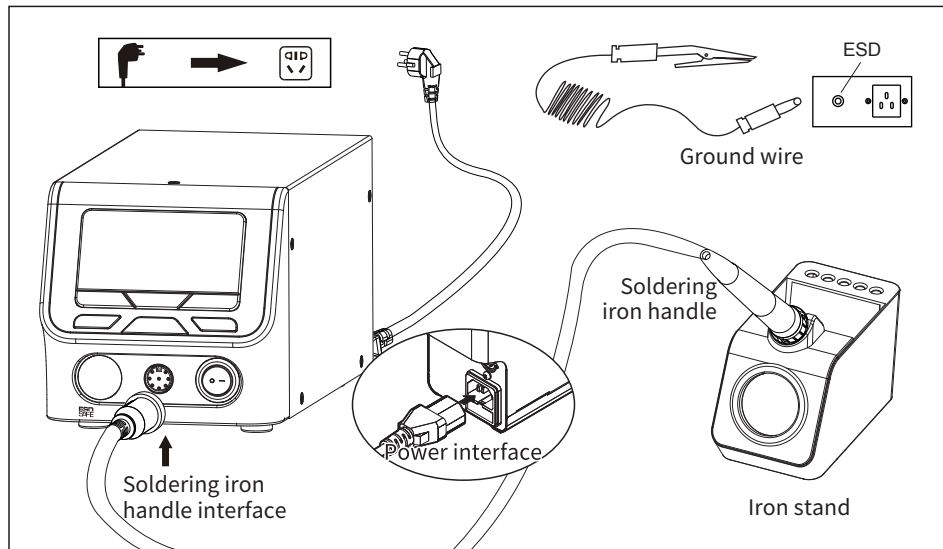

• Communication function (applicable to models with communication function)

- This product has built-in USB and RS485 communication interfaces, and can communicate using the MOUBUS protocol. Please log in to the company official website to download the corresponding DEMO software and communication protocol documents.

• Soldering iron tip and heater accessories

- Please enter company's official website or contact the local dealer and manufacturer for assistance.

06/Soldering tip and heater changing:

⚠ warning

Replace the heating core and soldering tip, be sure to cut off the power supply and wait until the heater and handle are completely cooled to room temperature.

• ST-9003D soldering tip changing:

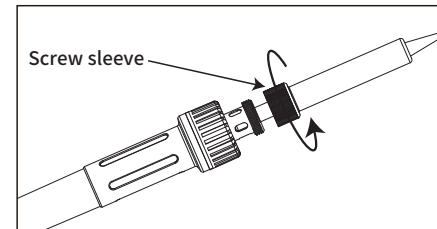

- ① Remove the screw sleeve as the direction indicated.

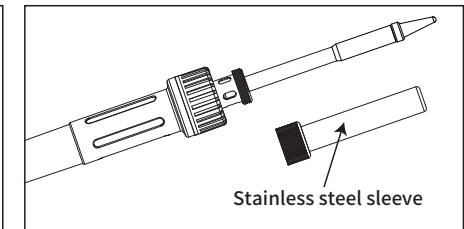

- ② Remove the stainless steel sleeve of the handle as shown.

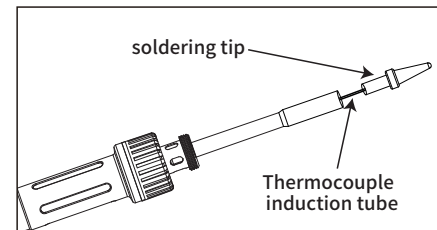

- ③ Remove the soldering tip and replace it with a new tip (note: the new soldering tip must be inserted into the thermocouple induction tube).

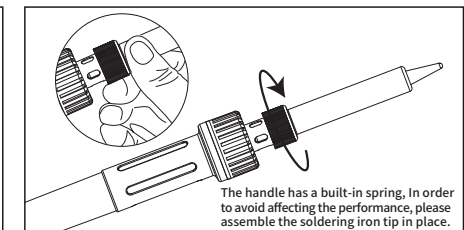

- ④ Following to the disassembly steps, assemble all parts in place and the soldering tip is replaced.

• **Vibration switch sensitivity setting:**

Mainly used to wake up the machine after entered standby mode. The higher sensitivity value of the vibration switch, its more sensitive.

Under the "Ubl" menu, short press the "▲" or "▼" key on the machine panel to set the Vibration switch sensitivity(Figure 1-25) (setting range: 1~3, default is 3) press "2" to confirm and choose to save the parameters.



(Fig 1-25)

• **IR temperature calibration function:**

Under the main menu, short press "MENU/ENTER" key to turn on/off the IR temperature calibration function.

(Fig. 1-26) Means: IR function is turn on (Main menu interface display **IR** icon).

(Fig. 1-27) Means: Used with ATTEN temperature tester (ST-1090) , the temperature tester infrared light should be aligned with the infrared receiver of the station, the recommended distance is 10cm~30cm, align the soldering iron handle with the thermometer temperature sensing point, after the temperature on thermometer screen is stable, press the thermometer "SEND" key, (If the temperature compensation is successful,"beep" will sound and "IR" will flash,and the host displayed temperature will be consistent with thermometer's displayed temperature.)

(Fig 1-28) Under the CAL menu,the temperature compensation value can be seen.

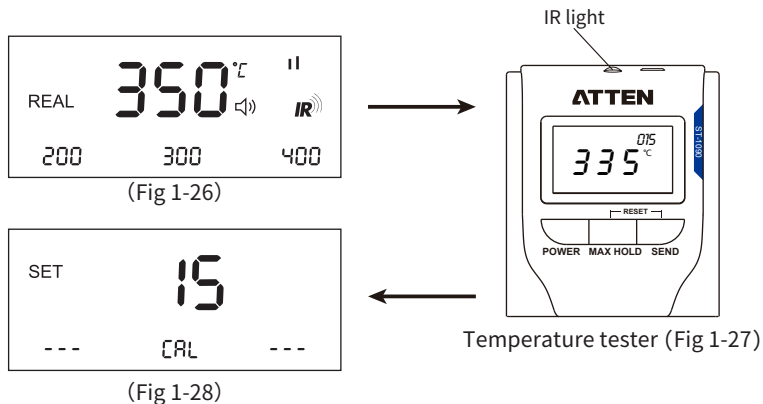

• **Boot-up screen**

After the station has been switched on, it will display the system version number for 1 seconds. (The version will change after system version updated, such as Ver: xx. xx stands for any number)



• **Working status**

• **Working normally**

(Fig. 1-1) Means: Current temperature preset value 350°C, heating power value 2, show real temperature.

• **Enter standby mode**

(Fig. 1-2) Means: In the absence of any operation, factory default for 3 mins enter standby LCD display "Stb", it is heating by 200°C. It will recover to normal work when taking handle up.(standby function can be turned off in menu setting.)

• **Enter sleep mode**

(Fig. 1-3) Means: The heating function is turned off, soldering iron handle it is not heating, press any key to return to work. (After standby function turn on, factory default for 30 mins enter sleep, sleep time can be customizable in menu setting.)

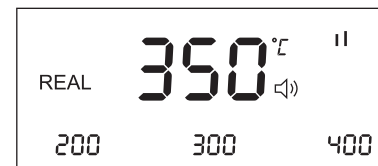

(Fig 1-1)

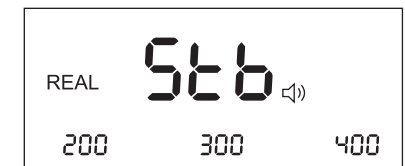

(Fig 1-2)

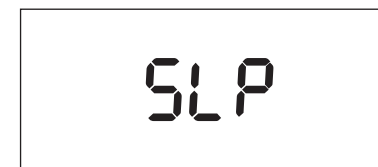

(Fig 1-3)

• **Temperature setting:**

Under the main menu, short press "▲" or "▼" key, temperature will be reduced or increased in 5% unit, long press for rapidly reduce or increase, wait for 3 seconds after set, the system will automatically save the setting. (the temperature value can not be adjusted when locked)

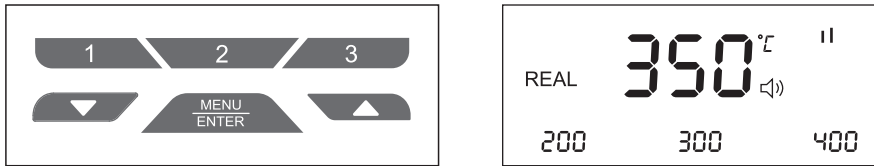

• **Quickly retrieve temperature:**

Under the main menu, short press "1", "2", and "3" keys to quickly retrieve the temperature value. (factory default: [1] key is 200°C, [2] key is 300°C, [3] key is 400°C)

• **Adjust pre-setting temperature:**

Under the main menu, long press (>3s) "1", "2", and "3" keys to save the current temperature value in the corresponding shortcut key.

05/ Menu setting

• Under the main menu, long press "MENU/ENTER" key for more than 3 seconds to enter menu setting. If no operation for 15 seconds, the system automatically return.

Button definitions in menu setting mode

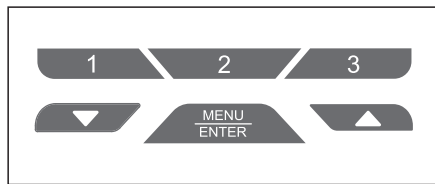

- [1] key: Up menu
- [2] key: Confirm selection & save
- [3] key: Down menu
- ▲ key: Parameters Increased
- ▼ key: Parameters Reduced

• **Temperature lock function:**

Under the "Loc" menu, long press "▲" and "▼" to set the temperature lock: Off/On (Fig 1-4), press "2" save parameters settings. (factory default turn off, when temperature lock function turn on, the current percentages temperature is locked, any temperature set is invalid)

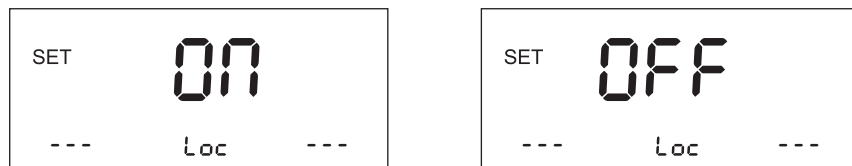

(Fig 1-4)

• **Online device power-on delay setting:**

Under the "t-01" menu, short press the "▲" or "▼" key on the panel of the machine to set the delay time for starting the online device (Figure 1-20) (setting range: 0~900s, default is 0) Press "2" to confirm and choose to save the parameters.

(Fig. 1-21) Means: The current machine has set the power-on delay, and the controlled equipment will start in "15S" after the host machine starts.



(Fig 1-20)



(Fig 1-21)

• **Online device shutdown delay setting:**

Under the "t-02" menu, short press the "▲" or "▼" key on the machine panel to set the shutdown delay time of the online device (Figure 1-22) (setting range: 0~900s, default is 0) press "2" to confirm and choose to save the parameters.

(Fig 1-23) Means: The current machine enters the standby state, and when the shutdown delay is "0", the controlled device enters the standby state at the same time. If the shutdown delay time has been set, the controlled device will enter standby according to the set delay time. (Pick up or touch the handle again to resume normal work)

(Fig 1-24) Means: The host and peripheral devices enter hibernation mode and press any key to resume normal operation



(Fig 1-22)

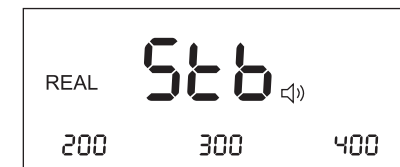

(Fig 1-23)

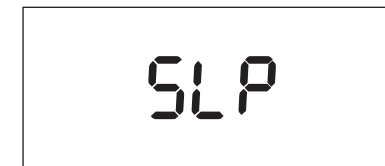

(Fig 1-24)

(Note: The delay between power-on and power-off is only valid in the host mode and the address code setting is consistent, and it needs to be used with ATTEN smoke purifier)

• Restore factory setting:

Under the "FAC" menu, short press "▲" and "▼" key to restore factory setting, when the select parameter "ON", press "2" save parameters settings. All settings are back to the factory settings.



(Fig 1-17)

Factory default:

Loc (Temperature lock) : OFF	Addr (Address) : 1
C-F (Temperature unit) : °C	SLa (Master-Slave mode) : ON
CAL (Temperature calibration) : 0°C	t01 (power-on delay) : 0
Stb (Standby function) : ON (Default 3 minutes)	t02 (shutdown delay) : 0
SLP (Auto-sleep function) : ON (Default 30 minutes)	UbL (Vibration switch sensitivity) : 3
bL (Beep setting) : ON	Shortcut temperature [1] : 200°C
PSd (Password setting) : - - -	Shortcut temperature [2] : 300°C
H-L (Temperature alarm function) : 20°C	Shortcut temperature [2] : 400°C

• Master-Slave mode setting:

Under the "SLa" menu, short press the "▲" or "▼" key on the panel of the machine to set the master-slave mode ("ON": means slave, "OFF": means master) press "2" key to confirm and save the parameters

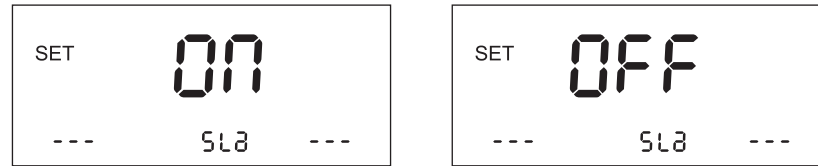

(Fig 1-18)

(Fig 1-19)

Note: Set the machine to [OFF] master mode, and set ATTEN smoke purifier address code to be the same. The machine can control the smoke purifier through the RS485 communication interface. (connect method is shown in the figure below)

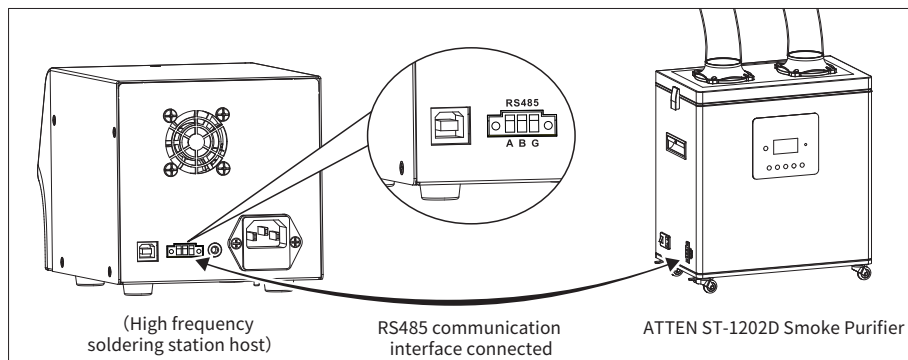

• Temperature unit exchange:

Under the "C-F" menu, short press "▲" and "▼" to exchange "°C" or "°F" temperature unit (Fig 1-5), press "2" save parameters settings. (factory default °C)

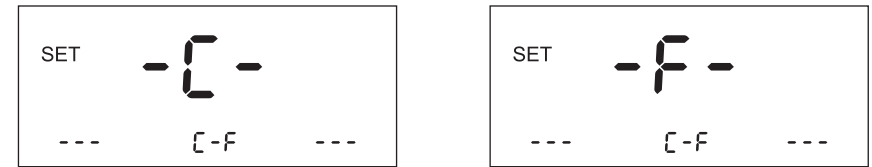

(Fig 1-5)

• Temperature calibration:

Under the "CAL" menu, short press "▲" and "▼" to set the temperature calibration value (Fig 1-6), (sett range: -50°C~50°C/-90°F~90°F), press "2" save parameters settings. (Calibration value will be negative as actual measured temperature is lower than setting temperature. calibration value will be positive as actual-measured temperature is higher than setting temperature)

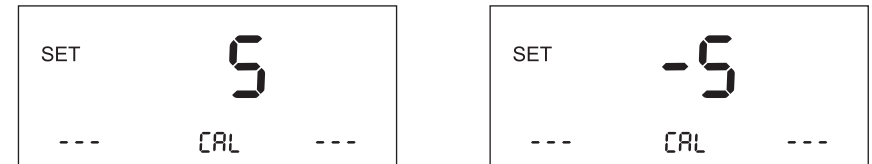

(Fig 1-6)

Note: User need calibrate temperature by adjusting its value if the displayed temperature is much different with actual-measured temperature after changing a new heater or tips, its calibration method be referred as below:

1. Set the this handle required calibration as a suitable temperature like 350°C/662°F.
2. After this setting temperature is stable, use temperature tester to measure the actual temperature of its tip.
3. For example, its actual-measured temperature is 365°C/689°F, we can get conclusion that the actual-measured temperature compared to the setting temperature is 15°C/27°F higher.
4. Then set the calibrate temperature to -15°C/-27°F to compensate the error of output temperature.

• Auto-standby setting:

Under the "Stb" menu, short press "▲" and "▼" to set the standby time (Fig 1-7), 1-60 minutes adjustable (Default 3 minutes), press "2" save parameters settings.

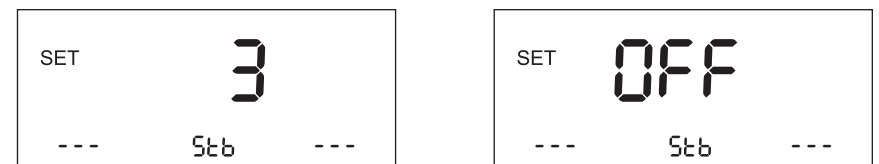

(Fig 1-7)

• **Auto-sleep setting:**

Under the "SLP" menu, short press "▲" and "▼" to set the standby after sleep time (Fig 1-8), 1~60 minutes adjustable (Default 30 minutes), press "2" save parameters settings. (Under the sleep state, the heating function is turned off, soldering iron handle it is not heating, press any key to return to work.)

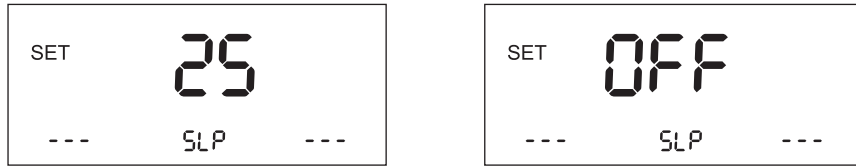

(Fig 1-8)

• **Beep setting:**

Under the "bL" menu, short press "▲" or "▼" key to turn the alarm function off/on (Fig 1-10) press "2" to save the setting.



(Fig 1-9)

• **Password setting:**

Under the "PSd" menu, short press "▲" or "▼" button to adjust the password setting value. The password value can be set from "001" to "999". After each value set press "MUNE" to save the parameters.

(Fig. 1-10) Means: password function is turn off.

(Fig. 1-11) Means: machine has set the password, short press "▲" or "▼" button the password, press "3" key cursor switch, after each value set press "MUNE" to save the parameters.

(Fig. 1-12) Means: password error.

Password removal: Under the "PSd" menu, to unlock the password, set the password to "000" or restore the factory Settings.

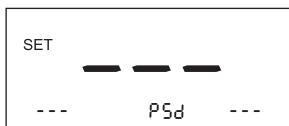

(Fig 1-10)



(Fig 1-11)

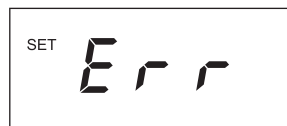

(Fig 1-12)

• **High temperature mode (Only for ST-3003D):**

Under the "H-L" menu, short press "▲" and "▼" to set the high temperature mode turn on or turn off (Fig 1-13), press "2" to save the setting.

(Note: when the high temperature is ON, the temperature can be adjusted to the maximum 600°C/1112°F under normal working condition; when the high temperature is OFF, the temperature can be adjusted from 80 °C to 500°C/176°F to 932°F.)



(Fig 1-13)

• **Temperature alarm function:**

Under the "H-L" menu, short press "▲" and "▼" to set the upper lower temperature values turn on or turn off (setting range: 20~80°C), press "2" to save the setting.

(Fig 1-14) Means: It will alarm if upper temperature more than 20°C and the lower temperature less than -20°C.

(Fig 1-15) Means: alarm function is OFF.

Note: alarm function turn on and emit regular sound, means the temperature percentage does not reach the set parameter.



(Fig 1-14)



(Fig 1-15)

• **Address setting:**

Under the "Addr" menu, press "▲" and "▼" to adjust the communication address range value, (Fig 1-16) which can be used for communication of multiple machines and can be connected at most 247 sets of equipment.

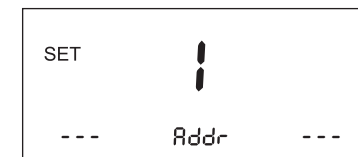

(Fig 1-16)