

Keysight 53210A/53220A/ 53230A 350 MHz Universal Frequency Counter/Timer



Assembly Level
Service Guide

Notices

Copyright Notice

© Keysight Technologies 2011–2018
No part of this manual may be reproduced in any form or by any means (including electronic storage and retrieval or translation into a foreign language) without prior agreement and written consent from Keysight Technologies as governed by United States and international copyright laws.

Trademarks

Microsoft and Windows are U.S. registered trademarks of Microsoft Corporation.

Manual Part Number

53220-90010

Edition

Edition 8, March 2018

Printed in:

Printed in Malaysia

Published by:

Keysight Technologies
Bayan Lepas Free Industrial Zone,
11900 Penang, Malaysia

Technology Licenses

The hardware and/or software described in this document are furnished under a license and may be used or copied only in accordance with the terms of such license.

Declaration of Conformity

Declarations of Conformity for this product and for other Keysight products may be downloaded from the Web. Go to <http://www.keysight.com/go/conformity>. You can then search by product number to find the latest Declaration of Conformity.

U.S. Government Rights

The Software is “commercial computer software,” as defined by Federal Acquisition Regulation (“FAR”) 2.101. Pursuant to FAR 12.212 and 27.405-3 and Department of Defense FAR Supplement (“DFARS”) 227.7202, the U.S. government acquires commercial computer software under the same terms by which the software is customarily provided to the public. Accordingly, Keysight provides the Software to U.S. government customers under its standard commercial license, which is embodied in its End User License Agreement (EULA), a copy of which can be found at <http://www.keysight.com/find/sweula>. The license set forth in the EULA represents the exclusive authority by which the U.S. government may use, modify, distribute, or disclose the Software. The EULA and the license set forth therein, does not require or permit, among other things, that Keysight: (1) Furnish technical information related to commercial computer software or commercial computer software documentation that is not customarily provided to the public; or (2) Relinquish to, or otherwise provide, the government rights in excess of these rights customarily provided to the public to use, modify, reproduce, release, perform, display, or disclose commercial computer software or commercial computer software documentation. No additional government requirements beyond those set forth in the EULA shall apply, except to the extent that those terms, rights, or licenses are explicitly required from all providers of commercial computer software pursuant to the FAR and the DFARS and are set forth specifically in writing elsewhere in the EULA. Keysight shall be under no obligation to update, revise or otherwise modify the Software. With respect to any technical data as defined by FAR 2.101, pursuant to FAR 12.211 and 27.404.2 and DFARS 227.7102, the U.S. government acquires no greater than Limited Rights as defined in FAR 27.401 or DFAR 227.7103-5 (c), as applicable in any technical data.

Warranty

THE MATERIAL CONTAINED IN THIS DOCUMENT IS PROVIDED “AS IS,” AND IS SUBJECT TO BEING CHANGED, WITHOUT NOTICE, IN FUTURE EDITIONS. FURTHER, TO THE MAXIMUM EXTENT PERMITTED BY APPLICABLE LAW, KEYSIGHT DISCLAIMS ALL WARRANTIES, EITHER EXPRESS OR IMPLIED, WITH REGARD TO THIS MANUAL AND ANY INFORMATION CONTAINED HEREIN, INCLUDING BUT NOT LIMITED TO THE IMPLIED WARRANTIES OF MERCHANTABILITY AND FITNESS FOR A PARTICULAR PURPOSE. KEYSIGHT SHALL NOT BE LIABLE FOR ERRORS OR FOR INCIDENTAL OR CONSEQUENTIAL DAMAGES IN CONNECTION WITH THE FURNISHING, USE, OR PERFORMANCE OF THIS DOCUMENT OR OF ANY INFORMATION CONTAINED HEREIN. SHOULD KEYSIGHT AND THE USER HAVE A SEPARATE WRITTEN AGREEMENT WITH WARRANTY TERMS COVERING THE MATERIAL IN THIS DOCUMENT THAT CONFLICT WITH THESE TERMS, THE WARRANTY TERMS IN THE SEPARATE AGREEMENT SHALL CONTROL.

Safety Information

CAUTION

A CAUTION notice denotes a hazard. It calls attention to an operating procedure, practice, or the like that, if not correctly performed or adhered to, could result in damage to the product or loss of important data. Do not proceed beyond a CAUTION notice until the indicated conditions are fully understood and met.

WARNING

A WARNING notice denotes a hazard. It calls attention to an operating procedure, practice, or the like that, if not correctly performed or adhered to, could result in personal injury or death. Do not proceed beyond a WARNING notice until the indicated conditions are fully understood and met.

Software Updates/Licenses

Periodically, Keysight releases software updates to fix known defects and incorporate product enhancements. To search for software updates and the latest documentation for your product, go to the product page at:

www.keysight.com/find/53210A

www.keysight.com/find/53220A

www.keysight.com/find/53230A

A portion of the software in this product is licensed under terms of the General Public License Version 2 (“GPLv2”). The text of the license and source code can be found at:

www.keysight.com/find/GPLV2

This product utilizes Microsoft Windows CE. Keysight highly recommends that all Windows-based computers connected to Windows CE instruments utilize current anti-virus software. For more information, go to the product page at:

www.keysight.com/find/53210A

www.keysight.com/find/53220A

www.keysight.com/find/53230A

Assistance

This product comes with the standard product warranty. Warranty options, extended support contacts, product maintenance agreements and customer assistance agreements are also available. Contact your nearest Keysight Technologies Sales and Service office for further information on Keysight Technologies' full line of Support Programs.

Certification

Keysight Technologies certifies that this product met its published specifications at time of shipment from the factory. Keysight Technologies further certifies that its calibration measurements are traceable to the United States National Institute of Standards and Technology, to the extent allowed by the Institute's calibration facility, and to the calibration facilities of other International Standards Organization members.

Exclusive Remedies

The remedies provided herein are the customer's sole and exclusive remedies. Keysight Technologies shall not be liable for any direct, indirect, special, incidental, or consequential damages, whether based on contract, tort, or any other legal theory.

Lithium Battery Recycling



The 53210A/53220A/53230A counters contain a 3 V “coin cell” lithium battery. Keysight recommends that this battery be replaced every year at the instrument’s 1-year calibration interval. Replacement procedures are provided in the 53210A/53220A/53230A Service Guide.

Option 300 provides battery operation of the 53210A/53220A/53230A using a 12 lithium battery. Performance of this battery will degrade over time as a function of the number of battery charge/discharge cycles.

Refer to local, state, or Federal regulations when disposing of, or recycling either battery.

Safety Symbols

The following symbols on the instrument and in the documentation indicate precautions which must be taken to maintain safe operation of the instrument.

	Standby Power. Unit is not completely disconnected from AC mains when power switch is in standby position.		Frame or chassis (ground) terminal
	Caution, risk of danger (refer to this manual for specific Warning or Caution information)	CAT I	IEC Measurement Category I. Do NOT connect inputs to AC mains or to circuits derived from AC mains.

Safety Information

The following general safety precautions must be observed during all phases of operation of this instrument. Failure to comply with these precautions or with specific warnings or operating instructions in the product manuals violates safety standards of design, manufacture, and intended use of the instrument. Keysight Technologies assumes no liability for the customer's failure to comply with these requirements.

General

Do not use this product in any manner not specified by the manufacturer. The protective features of this product may be impaired if it is used in a manner not specified in the operation instructions.

Before applying power

Verify that all safety precautions are taken. Note the instrument's external markings described under "Safety Symbols".

Ground the instrument

The Keysight 53210A/53220A/53230A is provided with a grounding-type power plug. The instrument chassis and cover must be connected to an electrical ground to minimize shock hazard. The ground pin must be firmly connected to an electrical ground (safety ground) terminal at the power outlet. Any interruption of the protective (grounding) conductor or disconnection of the protective earth terminal will cause a potential shock hazard that could result in personal injury.

Fuses

The Keysight 53210A/53220A/53230A is provided with an internal line fuse appropriate for the line voltages listed on the instrument. This fuse is not user accessible.

Do not operate in an explosive atmosphere

Do not operate the instrument in the presence of flammable gases or fumes.

Do not operate near flammable liquids

Do not operate the instrument in the presence of flammable liquids or near containers of such liquids.

Do not remove the instrument cover

Only qualified, service-trained personnel who are aware of the hazards involved should remove instrument covers. Always disconnect the power cable and any external circuits before removing the instrument cover.

Do not modify the instrument

Do not install substitute parts or perform any unauthorized modification to the product. Return the product to a Keysight Sales and Service Office for service and repair to ensure that safety features are maintained.

In case of damage

Instruments that appear damaged or defective should be made inoperative and secured against unintended operation until they can be repaired by qualified service personnel.

Cleaning the instrument

Clean the outside of the instrument with a soft, lint-free, slightly-dampened cloth. Do not use detergents or chemical solvents.

WARNING

Do not connect the input channels of the 53210A/53220A/53230A to AC line-voltage mains or to circuits derived from AC mains. The instrument must be used in CAT I (isolated from mains) applications only. Do not use in other IEC Measurement Category (CAT II, CAT III, or CAT IV) applications. Failure to observe these precautions may result in electric shock and serious personal injury.

WARNING

The BNC shells of the input terminals are connected to the instrument chassis. Verify signal polarity before making any connections to the input terminals.

Protection limits

The Keysight 53210A/53220A/53230A 350 MHz Universal Frequency Counter/Timer provides protection circuitry to prevent damage to the instrument and to protect against the danger of electric shock, provided the Protection Limits are not exceeded and the instrument is properly grounded. To ensure safe operation of the instrument, do not exceed the Protection Limits defined on the front panel:

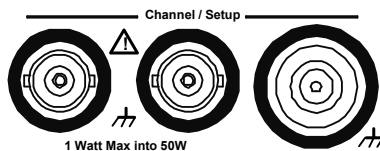
**WARNING**

During battery operation, the maximum measured signal supplied by the user is +42 V.

WARNING

Product Options 201/202 add parallel Channel 1 and Channel 2 inputs to the rear panel of the instrument. Signals on the center conductor of either panel's channel BNCs are also present on the corresponding center conductor of the BNC on the opposite panel.

Installing the instrument

The Keysight 53210A/53220A/53230A operates in the following line-voltage ranges:

100 V to 240 V, 50 Hz to 60 Hz

100 V to 127 V, 440 Hz

90 VA Max

Instrument ventilation is through the sides and rear. Do not obstruct the ventilation holes in any of these locations.

Battery operation

When operating the 53210A or 53220A under battery power (Option 300), failure to observe the following warnings may result in damage to the instrument, electric shock, and serious personal injury:

WARNING

Connect the instrument chassis to earth ground during battery operation to minimize shock hazard. Any interruption or disconnection of the protective earth terminal will cause a potential shock hazard that could result in personal injury.

WARNING

Under battery power, the instrument chassis may float to the potential of the measured signal supplied by the user.

Waste Electrical and Electronic Equipment (WEEE) Directive

This instrument complies with the WEEE Directive marking requirement. This affixed product label indicates that you must not discard this electrical or electronic product in domestic household waste.

Product category:

With reference to the equipment types in the WEEE directive Annex 1, this instrument is classified as a “Monitoring and Control Instrument” product.

The affixed product label is as shown below.



Do not dispose in domestic household waste.

To return this unwanted instrument, contact your nearest Keysight Service Center, or visit <http://about.keysight.com/en/companyinfo/environment/takeback.shtml> for more information.

Sales and Technical Support

To contact Keysight for sales and technical support, refer to the support links on the following Keysight websites:

- www.keysight.com/find/53210A
www.keysight.com/find/53220A
www.keysight.com/find/53220A
(product-specific information and support, software and documentation updates)
- www.keysight.com/find/assist
(worldwide contact information for repair and service)

Table of Contents

Software Updates/Licenses	3
Assistance	4
Certification	4
Exclusive Remedies	4
Lithium Battery Recycling	5
Safety Symbols	5
Safety Information	6
General	6
Before applying power	6
Ground the instrument	6
Fuses	6
Do not operate in an explosive atmosphere	7
Do not operate near flammable liquids	7
Do not remove the instrument cover	7
Do not modify the instrument	7
In case of damage	7
Cleaning the instrument	7
Protection limits	8
Installing the instrument	9
Battery operation	9
Waste Electrical and Electronic Equipment (WEEE) Directive	10
Product category:	10
Sales and Technical Support	10
1 Performance Tests	
Introduction	24
Chapter overview	25
Recommended calibration cycle	27
Internal auto-calibration	27
Equipment required	28
Power-On Test	29

Self-Test (Q)	31
Run internal self-test	31
Keysight 53210A/53220A/53230A Operational Verification	33
Frequency checks	33
Termination checks (optional)	35
Keysight 53210A/53220A/53230A Complete Performance Tests	37
Test 1: (Q) Absolute time base	38
Test 2: (Q) Frequency accuracy - channels 1 and 2	43
Test 3: Single period	49
Test 4: (Q) Pulse width	55
Test 5: (Q) Time interval	60
Test 6a: (Q) Frequency accuracy - channel 2/3, option 106 (6 GHz microwave channel)	65
Test 6b: (Q) Frequency accuracy - channel 2/3, option 115 (15 GHz microwave channel)	71
Test 7a: (Q) Pulse burst frequency - 53230A channel 3 option 150 with option 106	77
Test 7c: (Q) Pulse burst frequency - 53230A channel 3 option 150 with option 115	83
Keysight 53210A/53220A/53230A Operational Verification and Performance Test Record	89
Keysight 53210A/53220A/53230A Performance Test Record (Tests 1 to 7)	90

2 Service

Introduction	100
Returning the counter to Keysight Technologies for service	100
About the Keysight 53210A/53220A/53230A calibration menu	100
The Keysight 53210A/53220A/53230A calibration procedures	100
Pre-troubleshooting information	100
Troubleshooting information	100
Returning the Instrument to Keysight Technologies for Service	104
Operating checklist	104
Is the instrument inoperative?	104

Does the instrument fail self-test?	104
Types of service available	104
Extended service contracts	104
Obtaining repair service (worldwide)	105
To provide repair information	106
To pack in the original packaging materials	107
To pack in commercially available materials	107
Warranty	108
About the Keysight 53210A/53220A/53230A Calibration Menu	109
Overview of the Keysight 53210A/53220A/53230A calibration menu	109
To get help with the calibration menu functions	111
To view the calibration menu and security status from the counter front panel	113
To lock the counter against calibration	114
To unlock the counter for calibration:	116
To change to a new security code	117
The Keysight 53210A/53220A/53230A Calibration Procedures	118
Equipment required	118
Determine the counter firmware version	119
Calibration cycle	121
Calibration string:	121
Internal reference oscillator calibration	121
Summary of oscillator calibration procedure:	126
Remote oscillator calibration summary:	126
Voltage calibration (internal DACs)	127
Option 106 microwave channel frequency calibration	133
Option 115 microwave channel frequency calibration	140
Internal auto-calibration	147
To view the calibration count	150
Resetting the security code to a null	151
Pre-Troubleshooting Information	152
Safety considerations	152
Recommended test equipment	153
Repair considerations	154

After service considerations	155
Troubleshooting the Counter	160
Unit is inoperative	160
Unit fails self-test	160
Power supply check	160
Checking the battery and battery charger	164
Performing the counter self-test	169
To determine the counter firmware version	170
Reseat the boards	172
Re-run the counter self test	173
Error Messages	174
Command errors (-100...)	174
Execution errors (-200...)	174
Hardware errors (-240, -241, -250...)	175
Device-specific errors (-300..., +800)	176
Query errors (-400...)	177
Calibration errors (700...)	177
Self-test errors (901...)	178

3 Replacing Assemblies

Introduction	182
Tools Required	183
Do this first	183
Electrostatic discharge	184
To Remove the Cover and Rear Bezel	185
To Remove the Internal DC Battery Assembly (Option 300)	187
To Remove the GPIB Assembly	189
To Remove a 6.0 GHz or 15.0 GHz Microwave Channel Assembly (Options 106/115)	190
Re-installing the microwave channel assembly	190
To Remove the Processor Board	193
To Remove the Front Panel Assembly	194
To remove the display assembly from the front panel	197

To Remove the Motherboard	198
To Remove the AC Power Supply Assembly	199

4 Retrofitting Options

Introduction	202
Tools required	202
Do This first	203
To Retrofit Ultra-High Stability Timebase (Option 010)	204
To Retrofit the GPIB Connector	205
GPIB connector parts (P/N 53200U-400)	205
Preliminary steps	205
GPIB connector installation procedure	206
To Retrofit the Internal Battery DC Power (Option 300)	207
Option 300 DC power input assembly parts	207
Preliminary steps	207
Battery assembly installation procedure	208
To Retrofit the 53210A (Channel 1) or 53220A/53230A (Channels 1/2) Rear Panel Inputs (Option 201)	213
Option 201 rear panel channel 1/2 parts	213
Preliminary steps	213
Channels 1/2 rear panel retrofit procedure	215
To Retrofit the 53210A Channel 2 Front Panel Input (Option 106 or Option 115, plus Front Panel Option 202)	217
Option 106/115 channel 2 parts	217
Option 202 front panel channel 2 parts	217
Preliminary steps	218
Channel 2 front panel retrofit procedure (53210A)	220
To Retrofit the 53210A Channel 2 Rear Panel Input, 6.0 GHz (Option 106) or 15.0 GHz (Option 115) plus Rear Panel Option 203	227
Option 106/115 channel 2 parts	227
Option 203 rear panel channel 2 parts	227
Preliminary steps	228
Channel 2 rear panel retrofit procedure (53210A)	230

To Retrofit the 53220A/53230A Channel 3 Input, 6.0 GHz (Option 106) or 15.0 GHz (Option 115) plus Front panel option 202	232
Option 202 front panel channel 3 parts	232
Preliminary steps	233
Front panel installation procedure (Option 202 only)	235
To Retrofit the 53220A/53230A Channel 3 Input, 6.0 GHz (Option 106) or 15.0 GHz (Option 115) plus Rear Panel Option 203	242
Option 203 rear panel channel 3 parts	242
Preliminary steps	243
Rear panel installation procedure (Option 203 only)	245
To Retrofit Option 150 (Pulse Microwave Measurements) for the 53230A	247
Retrofitting procedure	247
5 Replaceable Parts	
Introduction	250
Contacting Keysight Technologies	251
By telephone (in the United States):	251
For mail correspondence, use the address below:	251
How To Order A Part	252
Parts Identification	252
Replaceable Parts	254
6 Backdating	
Introduction	260
Serial numbers	260
Backdating Firmware	262
To determine the counter firmware version	262
Procedure Changes	264
Information concerning Option 106 “Microwave Input”, FW Rev (27.0)	264

Option 106 microwave channel frequency calibration	264
Backdating Hardware	271
Backdating Specifications	272

THIS PAGE HAS BEEN INTENTIONALLY LEFT BLANK.

List of Figures

Figure 1-1	Operational verification setup for Keysight 53210A/220A/230A	33
Figure 1-2	Termination Check Setup	35
Figure 1-3	Absolute timebase test setup	39
Figure 1-4	Test setup for channel 1/2 frequency accuracy tests	43
Figure 1-5	Test Setup for Single Period	50
Figure 1-6	Pulse width test setup	56
Figure 1-7	Time interval (channel 1 to 2) test setup	61
Figure 1-8	Option 106 (6 GHz) microwave channel 2/3 test setup	66
Figure 1-9	Option 115 (15 GHz) microwave channel 2/3 test setup	72
Figure 1-10	Option 106/150 microwave channel 3 test setup	78
Figure 1-11	Option 115/150 microwave channel 3 test setup	84
Figure 2-1	The front panel at a glance	101
Figure 2-2	Front panel display	102
Figure 2-3	Calibration procedure summary	112
Figure 2-4	Information screen	120
Figure 2-5	Oscillator calibration setup	122
Figure 2-6	DC voltage source and DMM connections	130
Figure 2-7	Microwave source connection to Channel 3	133
Figure 2-8	Microwave source connection to Channel 3	141
Figure 2-9	Counter top internal view	158
Figure 2-10	Bottom internal view	159
Figure 2-11	ac Power Supply Testpoint Locations on the Motherboard assembly (top view, internal battery removed, test points visible.)	162
Figure 2-12	Battery folded in the service position	165
Figure 2-13	Test Button and Charge Indicator	166
Figure 3-1	Handle removal	185
Figure 3-2	Rear Bezel And Cover Removal	186
Figure 3-3	Battery assembly temporary position for service or Removal	188
Figure 3-4	Top view of counter showing GPIB assembly	189

Figure 3-5	Front flange resting on plastic tab	191
Figure 3-6	Processor PC board	193
Figure 3-7	Front rubber bumper removal	194
Figure 3-8	Front panel removal	195
Figure 4-1	Connector Locking Tab	208
Figure 4-2	Jumper cable installed	209
Figure 4-3	Digital and Y-cables.	210
Figure 4-4	Test button and charge indicator	210
Figure 4-5	Battery assembly connectors	211
Figure 4-6	Battery assembly held by three small tabs	212
Figure 4-7	Option 201 rear input channels 1 and 2	215
Figure 4-8	53210A channel 2 front panel Option 106/202	219
Figure 4-9	Processor printed circuit board	220
Figure 4-10	T20 TORX screw on motherboard	221
Figure 4-11	Connector-adapter installation	222
Figure 4-12	Semi-rigid cable position	223
Figure 4-13	Front flange resting on plastic tab	225
Figure 4-14	53210A channel 2 rear panel Option 106/203	229
Figure 4-15	Channel 2 assembly installed on top of the motherboard, with the SMA edge connector pointing toward the rear of the counter.	230
Figure 4-16	53220A/53230A Option 106/202.	234
Figure 4-17	Processor printed circuit board.	235
Figure 4-18	T20 TORX screw on motherboard	236
Figure 4-19	Connector-adapter parts	238
Figure 4-20	Semi-rigid cable position	239
Figure 4-21	53220A/53230A rear panel option 106/203.	244
Figure 4-22	Channel 3 assembly installed on top of the motherboard, with the female SMA edge connector pointing toward the rear.	245
Figure 5-1	Keysight 53210A/53220A/53230A Counters, top view (cover off)	257
Figure 5-2	Keysight 53210A/53220A/53230A Counters, bottom view (cover off)	258
Figure 6-1	Information screen	263
Figure 6-2	Microwave source connection to channel 3	265

List of Tables

Table 1-1	Recommended test equipment for operational verification and performance tests	28
Table 1-2	The Keysight 53210A/53220A/53230A performance tests	38
Table 2-1	Recommended test equipment for calibration	118
Table 2-2	Option 106 calibration frequencies and power levels	137
Table 2-3	Option 115 calibration frequencies and power levels	145
Table 2-4	Recommended equipment for test and troubleshooting	153
Table 2-5	Keysight 53210A/53220A/53230A assembly identification	156
Table 2-6	DC power supply voltages	163
Table 5-1	Table of replaceable parts	254
Table 6-1	Instruments this guide directly applies to	260

THIS PAGE HAS BEEN INTENTIONALLY LEFT BLANK.

1 Performance Tests

Introduction	24
Power-On Test	29
Self-Test (Q)	31
Keysight 53210A/53220A/53230A Operational Verification	33
Keysight 53210A/53220A/53230A Complete Performance Tests	37
Keysight 53210A/53220A/53230A Operational Verification and Performance Test Record	89
Keysight 53210A/53220A/53230A Performance Test Record (Tests 1 to 7)	90

Verifying specifications.

Introduction

This chapter provides procedures to test the electrical performance of the Keysight 53210A/53220A/53230A Frequency Counters, using the specifications provided on the CD-ROM (“Keysight 53210A/53220A/53230A Specifications”) that came with your counter. Successful completion of all the performance tests verifies the counter is meeting all factory specifications.

Four types of testing are provided:

- Power-on test
- Counter self-test
- operational Verification Tests
- Complete performance tests

This chapter is organized as follows:

- Introduction
- Power-On Test
- Self-Test (Q)
- Keysight 53210A/53220A/53230A Operational Verification
- Keysight 53210A/53220A/53230A Complete Performance Tests
- Keysight 53210A/53220A/53230A Operational Verification and Performance Test Record
- Keysight 53210A/53220A/53230A Performance Test Record (Tests 1 to 7)

Chapter overview

Power-on test

When the counter is first turned ON, a limited turn-on test is performed to verify the counter is sufficiently functional to perform basic operations.

Self-test

Running the counter Self-Test initiates a series of checks against internal standards. Successful completion of the Self-Test provides a high confidence level that the counter is completely functional. No external test equipment is required for this operator-initiated test.

Operational verification

The operational verification is an abbreviated check that may be performed to give a strong degree of confidence that the instrument is capable of making basic measurements accurately without running the complete performance tests. An operational verification is useful for incoming inspection and routine preventative maintenance.

Complete performance verification tests

The complete performance verification tests verify the specifications listed on the Keysight 53210A/53220A/53230A Product Reference CD-ROM as “Keysight 53210A/53220A/53230A Specifications.” All tests can be performed without accessing the inside of the instrument. The complete performance tests are recommended as acceptance tests upon initial receipt of your counter. They will also help you to become familiar with its performance and operation. Complete performance tests should be run at least once a year to ensure the counter is meeting all specifications.

Quick performance check A combination of selected performance tests (marked ‘Q’) plus the counter **Self-Test** provides a simple method to achieve a high confidence in the counter’s ability to both functionally operate and to meet specifications. These tests represent the absolute minimum set of performance checks recommended following any service activity.

Auditing the counter's performance for the quick check points (designated by a 'Q') verifies performance for normal accuracy drift mechanisms.

This test does not check for abnormal component failures. To perform the quick performance check, do the following:

- Perform the counter **Self-Test** as shown on [page 31](#).
- Perform only the performance verification tests indicated with the letter **Q** at the beginning of the test.
- If the counter fails the quick performance check, repair may be required. Refer to ["Troubleshooting the Counter"](#) on page 160.

Remote testing of the counter

All of the counter tests may be run using an automated test system and remote programming commands. Three interfaces are provided in each counter to allow operation over an interface from a remote computer: GPIB, LAN, and USB. Refer to the SCPI Programmer's Reference for information on the remote commands available for controlling the counter.

Performance test record

The results of the operational verification, and performance tests should be recorded on a copy of the Performance Test Record, located at the end of the complete performance tests section in this chapter.

Test considerations

For optimum performance, all performance tests should comply with the following recommendations:

- Ensure that the ambient temperature for running the Performance Tests is stable and between 18 degrees C and 28 degrees C. Ideally, the tests should be performed at $23^{\circ}\text{C} \pm 1^{\circ}\text{C}$.
- Ensure that ambient relative humidity is less than 80%.
- See [page 37](#) for warm-up considerations.
- Keep the instrument cables as short as possible, consistent with the impedance requirements. Use only RG-58 or equivalent 50 Ω cable for measurements.

- To verify the total number of accuracy places for frequency measurements, it may be necessary to turn off Auto-Digit control. Use this set of key depressions to turn AutoDigits OFF:

[Digits] / (AutoDigits) / <Off>

- The softkey menus shown in the test procedures represent the functionality of the 53230A. The softkey menus for the 53210A and 53220A may be different depending on the function selected.

Recommended calibration cycle

The counter requires periodic verification of operation. Depending on the use and environmental conditions, aging, and measurement accuracy required, the counter should be checked using the operational verification procedure *at least* once every year. The recommended calibration cycle for specification accuracy is also one year.

Internal auto-calibration

An Internal Auto-Calibration feature is available (see [Chapter 2, "Service"](#)) that uses internal instrument standards to refine the accuracy of the counter. It is recommended that Auto-Cal be performed regularly (such as at the beginning of a shift change, starting a contemporary series of measurements, after a large ambient temperature change, etc.) for optimum counter performance.

NOTE

Auto-calibration is also a subset of the counter self-test.

Equipment required

Table 1-1 Recommended test equipment for operational verification and performance tests

Instrument	Required characteristics	Recommended model
Microwave signal generator	100 MHz to 15 GHz; Freq Accy at 6 GHz and 15 GHz: ± 10 ppb; PW Accy: $\pm 10\%$	Keysight E8257D-520-UNW or equivalent
Pulse generator	5 nSec pulse width \pm 40 pSec	Keysight 81134A or equivalent
RF signal generator	10 MHz \pm 2.000E-12	Stanford Research Systems CG635
Primary frequency standard (10 MHz house standard)	Absolute accuracy $>$ 1×10^{-10}	Stanford Research Systems FS725 Rubidium Timebase or equivalent
DC power supply	Adjustable to 5.000V	Keysight 6234A or equivalent
Digital multimeter (DMM)	Microvolt accuracy	Keysight 34410A or equivalent
SMA(m)-to-BNC(f) adapters (3)		Keysight 1250-1200
Type N(m)-to-BNC(f) adapter		Keysight 1250-0780
BNC-to-dual banana plug	BNC(f) to banana plug (m)	Keysight E9637A or Newark 10M4161
50 Ω coaxial cable with BNC connectors (5)	BNC(m) to BNC(m), 48 inches	Keysight 10503A
3.5mm cables (2)	DC-18 GHz, matched pair	Keysight 11500E
Coaxial BNC tee connector		Keysight 1250-0781

Power-On Test

- 1 Inspect the counter for any damage. Make sure no cables are connected to the input channels (rear and front panels) of the counter.
- 2 Connect the power cord to the counter, and connect the other end of the power cord to the primary power source.

NOTE

It is normal for the fan in the counter to run at different speeds as necessary (depending upon internal temperature) when the counter is in standby mode. Power to the timebase is continuous to maintain long term measurement reliability, and the fan helps maintain timebase temperature stability.

- 3 Verify the following condition for the Power LED with power off (lower L/H corner of the front panel).
 - No OCXO or OCXO in Off mode - LED is off when power is off.
 - OCXO present, heated by AC power - LED is on solid when power is off.
 - OCXO present, heated by battery power - LED blinks when power is off.
- 4 Press the **POWER** key (lower left-hand corner of the front panel) to turn on the counter. Verify the following results:
 - The front panel display turns white as all pixels are illuminated.
 - The LED under the power switch is on solid.
 - After several seconds, a screen is briefly displayed that shows the status and ID of the IP Address and the GPIB address. The factory default GPIB address is 3. (“Disabled” means the GPIB is turned **Off** under **[Utility] / (I/O Config)**).
 - The counter is now ready to measure frequency of a signal applied to CHANNEL 1 input as indicated by illumination of the **Freq** softkey and Channel **1** annunciator.

NOTE

An auto-cal is performed at power-on. (See **“To run auto calibration:”** on page 148 for more information.)

NOTE

If a fail message is displayed at power-on, refer to **“Troubleshooting the Counter”** on page 160 of this service guide.

- 5 Mark Pass or Fail in the Keysight 53210A/53220A/53230A Power-ON Test Record, Test 1, at the end of this chapter.

NOTE

The power-on hardware initialization activities check the following circuits for operation:

- Front panel display driver
 - Power manager
 - Battery (if installed)
 - GPIB
 - Measurement board hardware
-

Self-Test (Q)

A brief power-on test occurs automatically whenever you turn on the counter. This limited test assures that the counter is functional.

NOTE

It is recommended that the counter Self-Test be performed to ensure that the instrument is completely functional before running the Operational Verification or Performance Tests.

NOTE

SELF-TEST and the remote command *TST perform the same internal tests.

An auto-calibration is performed as a subset of the counter Self-Test. (See ["Internal auto-calibration"](#) on page 147 for more information.)

After turn-on, or at any time a reasonable operational status needs to be verified, the internal Self-Test can be run.

Run internal self-test

- 1 Disconnect any input signal(s) from the counter.
- 2 Press the **Utility** key and then the **Instr Setup** softkey.

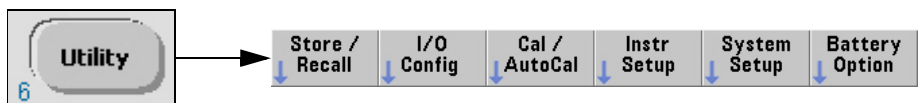

1 Performance Tests

The Instrument Setup menu softkeys are displayed:



- 3 Press the **Self Test** softkey. The display shows:
 - “**Performing Self-Test. Please wait...**” (displayed for several seconds.)
 - If the self-test passes, “**Self-Test Passed.**” is momentarily displayed.

NOTE

If “**Self-Test Failed**” is displayed or any other failure is indicated, refer to the troubleshooting section in [Chapter 2, "Service" on page 99](#).

- 4 Mark Pass or Fail in the [“Keysight 53210A/53220A/53230A Performance Test Record \(Tests 1 to 7\)”](#) on page 90.

Keysight 53210A/53220A/53230A Operational Verification

The operational verification consists of checks that may be performed at any time to give a high degree of confidence that the instrument is operating properly, without running the complete performance tests.

These checks represent the minimum set of tests recommended following any option retrofit installations (Refer to [Chapter 4, "Retrofitting Options"](#)).

If you are unfamiliar with the operation of the counter, you can review the "Keysight 53210A/53220A/53230A Quick Start Tutorial." However, the procedures in this chapter are written so that little operational experience is necessary. The procedures should be followed in the order in which they appear.

Frequency checks

- 1 Connect the counter's rear-panel **Int Ref Out** as shown in [Figure 1-1](#) to the front panel Channel 1 input connector.

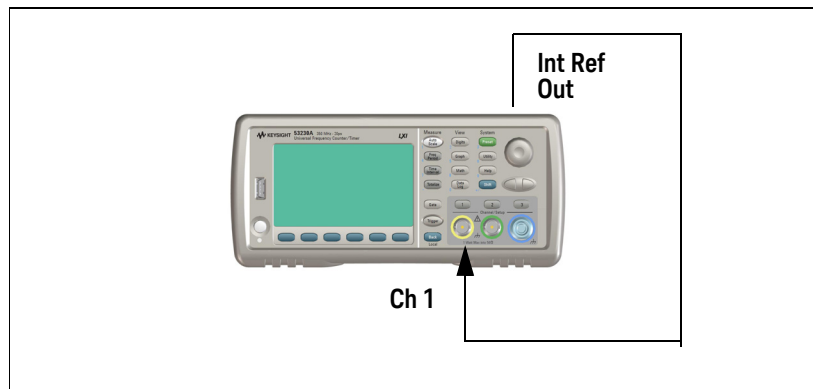

Figure 1-1 Operational verification setup for Keysight 53210A/220A/230A

NOTE

If the counter has Option 201 (rear panel input connectors) installed, connect the **Int Ref Out** to the rear panel Channel 1 input connector and NOT the front panel Channel 1 input connector.

1 Performance Tests

- 2 Press the **Preset** key to preset the counter.
- 3 Verify the display shows a frequency reading of approximately 10,000,000 Hz.
- 4 Mark Pass or Fail in the “**Keysight 53210A/53220A/53230A Performance Test Record (Tests 1 to 7)**” on page 90.

NOTE

The remaining steps apply only to the Keysight 53220A and Keysight 53230A since the Keysight 53210A does not have a second RF frequency input.

- 5 In the same way as for Channel 1, connect the **Int Ref Out** to the Channel 2 input connector (front or rear panel).
- 6 Press the Channel 2 button.

NOTE

If necessary, press the **Freq/Period** key to read the Channel 2 frequency.

- Channel 1 annunciator is not lit. Channel 2 annunciator is lit.
-

- 7 Verify the display shows a frequency reading of approximately **10,000,000 Hz**.
- 8 Mark Pass or Fail in the “**Keysight 53210A/53220A/53230A Performance Test Record (Tests 1 to 7)**” on page 90.
- 9 Disconnect the test setup.

Termination checks (optional)

NOTE

Once the termination checks have been successfully performed, it is usually not necessary to run them again unless the counter's motherboard has been replaced.

- 1 Press the **Preset** key to preset the counter.
- 2 Connect a digital multimeter (DMM) to **CHANNEL 1** as shown in Figure 1-2, and set it to measure ohms (set DMM to appropriate Ohms range). On the DMM, use a dual-banana plug-to-BNC connector.

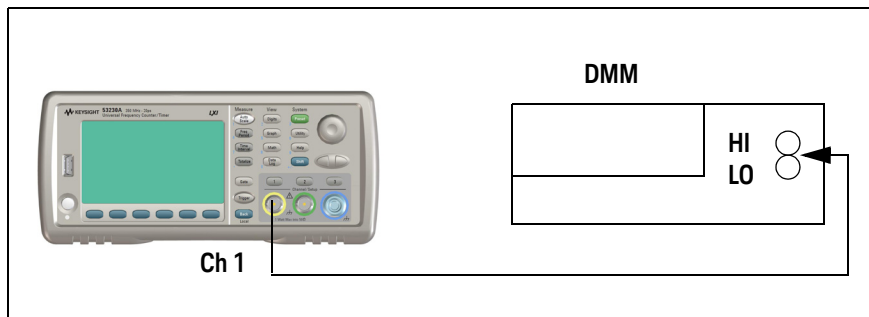
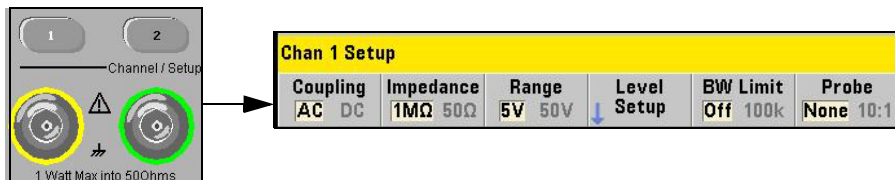

Figure 1-2 Termination Check Setup

- 3 Press the Channel 1 key.
 - The LED turns on and the Channel 1 Setup softkeys are displayed:



1 Performance Tests

- 4** Select the following:
 - Coupling: **DC**
 - The **DC** annunciator indicates DC input coupling for Channel 1.
 - Impedance: **50 Ω**
 - The **50 Ω** annunciator turns on, indicating a 50 Ω input impedance for Channel 1.
- 5** Verify the DMM reads approximately 50 Ohms.
- 6** Mark Pass or Fail in the “Keysight 53210A/53220A/53230A Performance Test Record (Tests 1 to 7)” on page 90.
- 7** Select the following:
 - Impedance: **1 M Ω** .
 - The **1 M Ω** annunciator turns on, indicating a 1 M Ω input impedance for Channel 1.
- 8** Verify the DMM reads approximately **1.000** MOhm.
- 9** Mark Pass or Fail in the “Keysight 53210A/53220A/53230A Performance Test Record (Tests 1 to 7)” on page 90.
- 10** Repeat steps 2 through 9 for RF Channel 2 for the Keysight 53220A/53230A counters ONLY, since the Keysight 53210A counter does not have a standard RF Channel 2.
- 11** Mark Pass or Fail in the Keysight 53220A/53230A Operational Verification Test Record, Tests 6a and 6b for Chan 2, starting on [page 90](#).
- 12** Disconnect the test setup.

NOTE

This completes the operational verification testing for the Keysight 53210A/53220A/53230A.

Keysight 53210A/53220A/53230A Complete Performance Tests

The following seven performance tests, when successful, verify that the counter meets the instrument specifications as provided on the CD ROM that came with your Keysight 53210A/53220A/53230A Counter. See also the information on running a 'QUICK' performance test on [page 25](#). Before running these tests, review the “[Test considerations](#)” on page 26.

Record the results of the performance tests in the appropriate place on the “[Keysight 53210A/53220A/53230A Performance Test Record \(Tests 1 to 7\)](#)” on page 90.

To verify the total number of accuracy places for frequency measurements, it may be necessary to turn off Auto-Digit control. Use this set of key depressions to turn AutoDigits OFF:

[Digits] / (AutoDigits) / <Off>

NOTE

If the instrument is currently located in the calibration environment with the power removed, turn on the instrument and allow a 45 minute warm-up period before starting the Performance Test procedures. Upon receipt and delivery to the calibration environment, turn on the instrument and allow a 2½ hour warm-up/stabilization period before starting the procedures.

If it is known that the instrument has been in storage or decommissioned (unused) for several months, turn on the instrument and allow it to stabilize for 72 hours. Periodically monitor the aging (drift) rate relative to the counter's 24-hour specification. If the aging rate exceeds the 24-hour specification, allow an additional stabilization period and continue to monitor the rate relative to the specification. The counter has stabilized when aging remains within the 24-hour rate. Otherwise, the 45 minute or 2½ warm-up period applies.

An instrument that has not or will not be used for several months should be stored in the same ambient environment and orientation in which it will eventually be used.

Table 1-2 The Keysight 53210A/53220A/53230A performance tests

[a] Test description
Test 1: Absolute time base
Test 2: Frequency accuracy - channels 1 and 2
Test 3: Single period
Test 4: Pulse width
Test 5: Time interval
Test 6: Frequency accuracy - microwave channel options 106 and 115
Test 7: Pulse burst frequency - 53230A channel 3 option 150

[a] Other counter measurement functions are mathematically derived by the processor from the parameters verified by these performance tests.

Test 1: (Q) Absolute time base

This test uses the Keysight 53210A/53220A/53230A Frequency Counters to measure the absolute frequency of the internal 10 MHz clock.

Equipment

- FS725 Rubidium timebase
- CG635 signal generator (E8257D-520 is a valid substitute)
- Keysight 10503 BNC cables (2)

CG635 signal generator setup

- 1** Set Output Channel: \bar{Q}
- 2** Set Output Level: +7 dBm
- 3** Set Frequency: **10 MHz**

Counter setup

- 1 Connect the equipment as shown in [Figure 1-3](#).

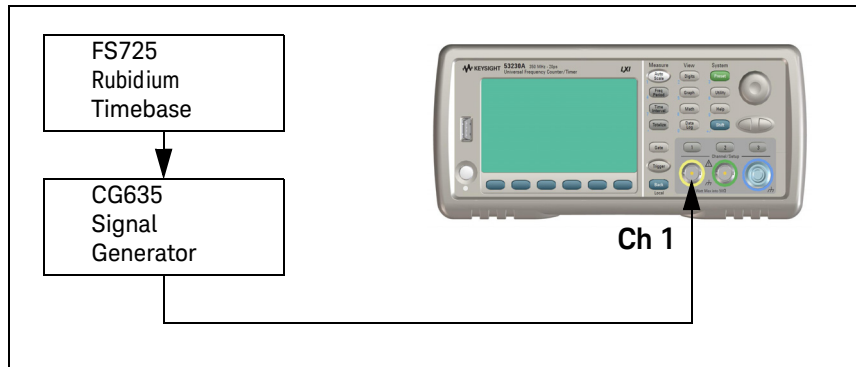

Figure 1-3 Absolute timebase test setup

- 2 Press the **Preset** key on the front panel to preset the counter.
 - Display shows:
 - **Instrument has been preset.**
 - Channel 1 annunciator is lit.
- 3 Press the **Trigger** key.
 - The following softkeys are displayed:



- 4 Press and set:
 - Trigger Source: **Manual**
 - **Wait For Trig** is displayed.
 - Rdgs/Trigger: *100*.

- 5 Press the **Freq Period** key.
 - The following softkeys are displayed:



- 6 Press the **Freq** softkey.
 - The following softkeys are displayed:



- 7 Press and set:
 - Noise Rejection: **Off**
- 8 Press the **Frequency/Period** key.
 - The following softkeys are displayed:

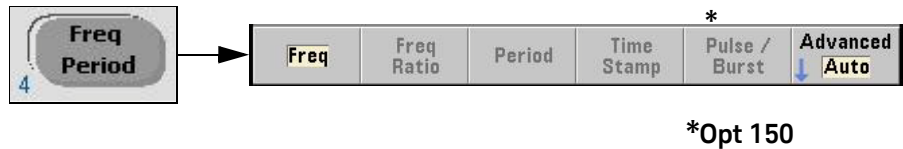

- If **Advanced** is appears, press **Auto** to select Auto measurement mode.

NOTE

The 53210A does not have an Auto measurement mode.

- 9 Press the Channel 1 input key.
- The following softkeys are displayed:



- 10 Press and set:
- Coupling: **DC**
 - Input Impedance: **50 Ω**
 - Range: **5 V**
 - Level Setup / Auto Level: **Off**
 - Level Setup / Input Level: **0.000 V**
 - BW Limit: **Off**
 - Probe: **None**
- 11 Press the **Math** key.
- The **Math** softkeys are displayed:



- 12 Press to set:
- All Math: **On**

13 Press the **Statistics** softkey:

- The **Statistics** softkeys are displayed:



14 Press to set:

- Statistics: **On**
- The display shows:

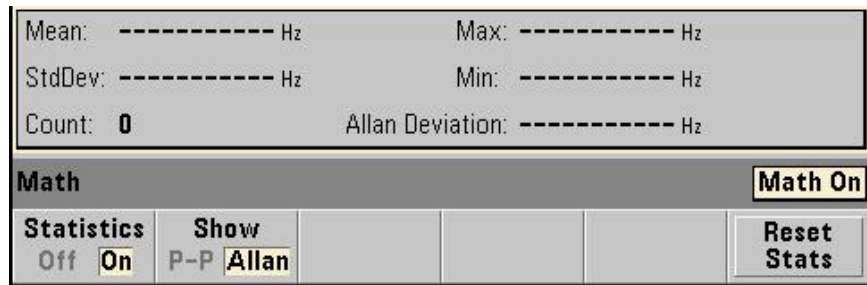

Absolute timebase test procedure

- 1 Press the **Trigger** key to manually trigger the counter.
 - Counter takes 100 readings and fills in Math functions.
- 2 Verify the 'Mean' displays a reading of:
 - 10 MHz ± 10 Hz (for standard timebase)
 - 10 MHz ± 0.5 Hz (for Option 010 high stability timebase)
- 3 Record the 'Mean' test value, Test 1, in the [“Keysight 53210A/53220A/53230A Performance Test Record \(Tests 1 to 7\)”](#) on page 90.
- 4 Proceed to Test #2 or disconnect the test setup.

Test 2: (Q) Frequency accuracy - channels 1 and 2

This set of tests verifies the Channel 1 and 2 frequency accuracy specifications of the Keysight 53210A/53220A/53230A Frequency Counters.

Equipment

- FS725 Rubidium timebase
- CG635 synthesized signal generator (E8257D-520 is a valid substitute)
- Keysight 10503A BNC cables (3)

CG635 signal generator setup

- 1 Set output channel: \bar{Q}
- 2 Set output level: +7 dBm
- 3 Set frequency: **10 MHz**

Counter setup

- 1 Connect the test equipment to the counter as shown in [Figure 1-4](#).

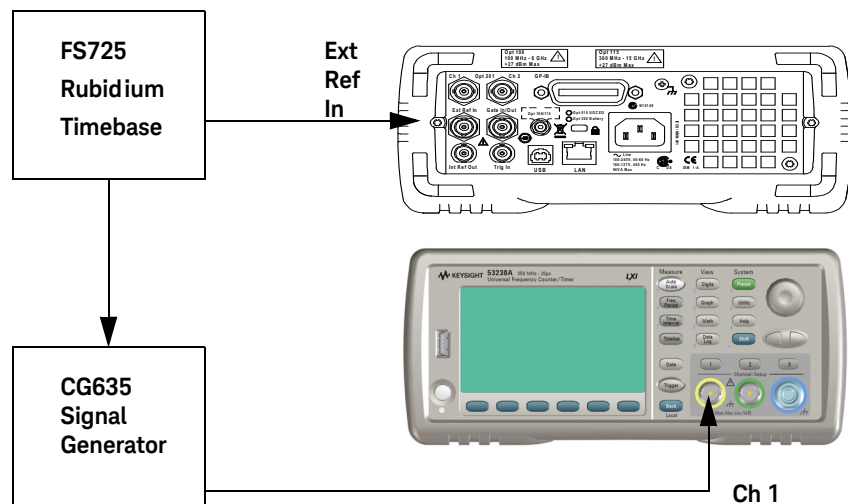
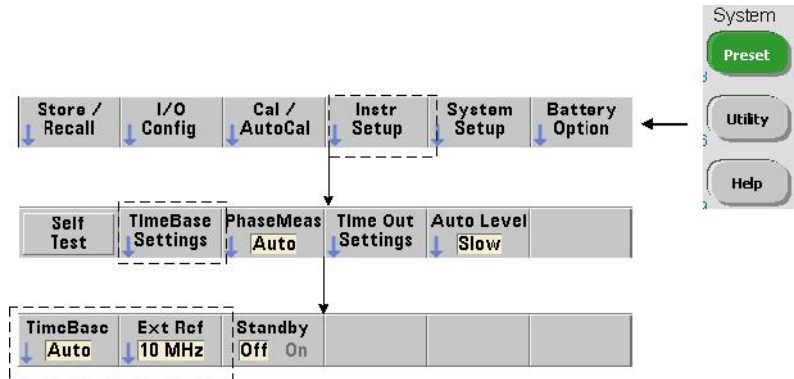

Figure 1-4 Test setup for channel 1/2 frequency accuracy tests

1 Performance Tests

- 2 With the external reference connected, use the following key sequence to select (as necessary) the time base source to 'Auto' or 'External', and the external reference frequency of 10 MHz:



- 3 Press the **Preset** key to preset the counter.
- Display shows:
 - **Instrument has been preset.**
 - **Ext Ref** is shown in the upper right-hand corner of the display.
 - The following softkeys are displayed:



*Opt 150

- 4 Press and set:
- Measurement mode: **Advanced / Auto**

NOTE

The 53210A does not have an Auto measurement mode.

- 5 Press the **Freq** softkey.
- The following softkeys are displayed:



- 6 Press and set:
- Noise Rejection: **Off**
- 7 Press the **Trigger** key.
- The following softkeys are displayed:

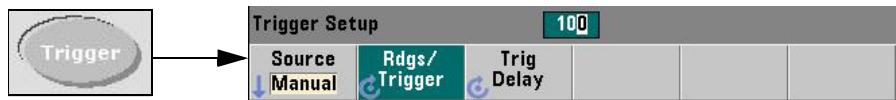

- 8 Press and set:
- Trigger Source: **Manual**
 - **Wait For Trig** is displayed.
 - Rdgs/Trigger: **100**
- 9 Press the **Gate** key.
- The **Gate** softkeys are displayed:



- 10 Press and set:
- Gate src: **Timed**
 - Gate time: **10 mSec**
 - Gate out: **On**
 - Polarity: **Norm**

11 Press the Channel 1 input key.

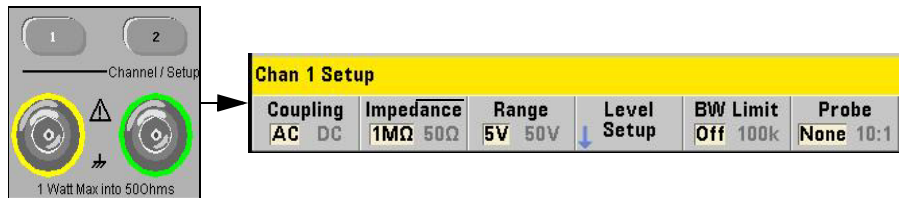

12 Press and set:

- Coupling: **DC**
- Input impedance: **50 Ω**
- Range: **5 V**
- BW Limit: **Off**
- Level Setup / Auto Level: **Off**
- Level Setup / Input Level: **0.000 V**

13 Press the **Math** key.

- The following softkeys are displayed:

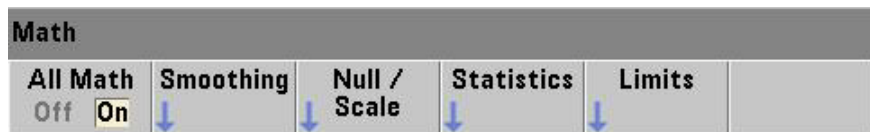

14 Press and set:

- All math: **On**

15 Press the **Statistics** softkey.

- The **Statistics** softkeys are displayed:



16 Press to set:

- Statistics: **On**
- The display shows:

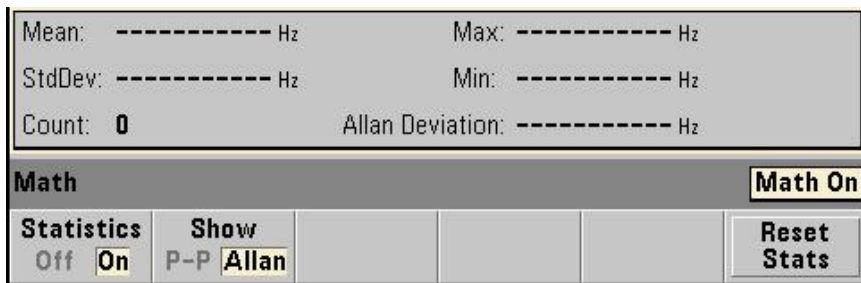

Frequency accuracy test procedure

- 1 Press the **Trigger** key to manually trigger the counter.
 - Counter takes 100 readings and fills in Math functions.
- 2 Verify the 'Mean' is:
 - 10 MHz \pm 100 mHz (for 53210A)
 - 10 MHz \pm 10 mHz (for 53220A/53230A)
- 3 Verify the 'Std Dev' is less than:
 - 140 mHz (for 53210A)
 - 70 mHz (for 53220A)
 - 14 mHz (for 53230A)

- 4 Record the 'Mean' and 'Std Dev', Test 2a, for Channel 1 (10 MHz), in the ["Keysight 53210A/53220A/53230A Performance Test Record \(Tests 1 to 7\)"](#) on page 90.
- 5 Press the **Reset Stats** softkey.
- 6 Set CG635 output frequency to 115 MHz and repeat step 1.
- 7 Verify the 'Mean' is:
 - 115 MHz \pm 1.150 Hz (for 53210A)
 - 115 MHz \pm 0.115 Hz (for 53220A/53230A)
- 8 Verify the 'Std Dev' is less than:
 - 1610 mHz (for 53210A)
 - 805 mHz (for 53220A)
 - 161 mHz (for 53230A)
- 9 Record the 'Mean' and 'Std Dev', Test 2a, for Channel 1 (115 MHz), in the ["Keysight 53210A/53220A/53230A Performance Test Record \(Tests 1 to 7\)"](#) on page 90.
- 10 Press the **Reset Stats** softkey.
- 11 Set CG635 output frequency to 350 MHz, and repeat step 1.
- 12 Verify the 'Mean' is:
 - 350 MHz \pm 3.5 Hz (for 53210A)
 - 350 MHz \pm 0.350 Hz (for 53220A/53230A)
- 13 Verify the 'Std Dev' is less than:
 - 4 900 mHz (for 53210A)
 - 2 450 mHz (for 53220A)
 - 490 mHz (for 53230A)
- 14 Record the 'Mean' and 'Std Dev', Test 2a, for Channel 1 (350 MHz), in the ["Keysight 53210A/53220A/53230A Performance Test Record \(Tests 1 to 7\)"](#) on page 90.
- 15 Press the **Reset Stats** softkey.
- 16 Repeat the procedure above (steps 1 to 15) for Channel 2. Be sure to set up Channel 2 (steps 11 and 12 under "Counter Setup".)

NOTE

Step 16 applies only to the 53220A and 53230A. The 53210A does not have a Channel 2 for RF frequencies. Also, selecting Channel 2 automatically resets the statistics.

17 Record the 'Mean' and 'Std Dev' for all three Channel 2 frequencies, Test 2b, Channel 2, in the ["Keysight 53210A/53220A/53230A Performance Test Record \(Tests 1 to 7\)"](#) on page 90.

18 Press the **Reset Stats** softkey.

19 Proceed to Test #3 or disconnect the test setup.

Test 3: Single period

This test measures a single period of a signal. The period is measured from rising edge to rising edge on a single channel.

NOTE

Test #3 applies to the 53220A and 53230A only.

Equipment

- FS725 Rubidium timebase
- CG635 Synthesized signal generator
- Keysight 10503 BNC cables (3)

CG635 signal generator setup

- 1** Set Output Channel: \bar{Q}
- 2** Set Output Level: +7 dBm
- 3** Set Frequency: **1 MHz**

Counter setup

- 1 Connect the equipment as shown in [Figure 1-5](#).

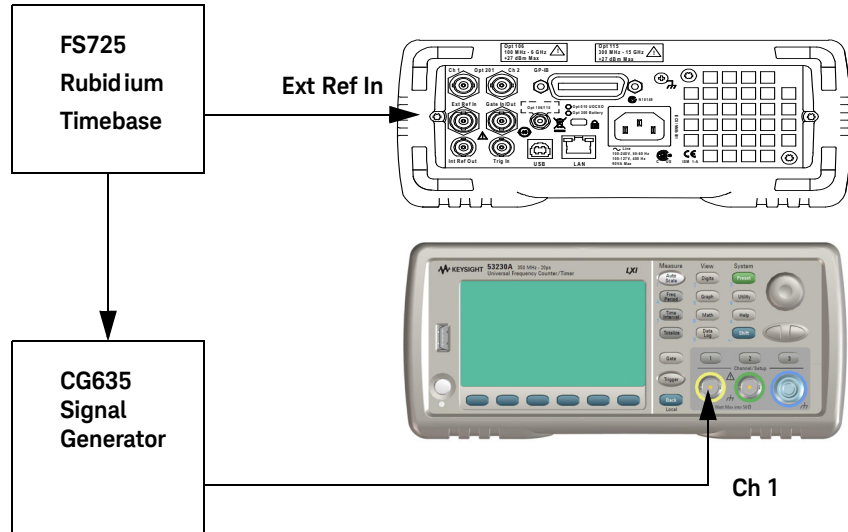

Figure 1-5 Test Setup for Single Period

- 2 Press the **Preset** key to preset the counter.
 - Display shows:
 - **Instrument has been preset.**
 - **Ext Ref** is shown in the upper right-hand corner of the display.
- 3 On the Counter, press the **Time Interval** key.
 - The following softkeys are displayed:



- 4 Press the Single **Period** softkey.
- The following softkeys are displayed:



- 5 Press and set:
- Auto Level: **Off**
 - Level: **0 V**
 - Noise Rej: **Off**
- 6 Press the **Channel 1** key.
- The Channel 1 Setup menu softkeys are displayed.

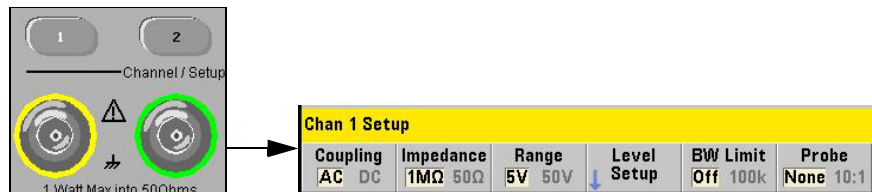

- 7 Press and set:
- Coupling: **DC**
 - Impedance: **50 Ω**
 - Range: **5 V**
 - BW Limit: **Off**
- 8 Press the **Trigger** key.
- The trigger softkeys are displayed:



1 Performance Tests

9 Press and set:

- Source: **Manual**
 - **Wait For Trig** is displayed.
- Trig Delay: **0 Seconds**
- Rdgs/Trigger: **100**

10 Press the **Math** key.

- The following softkeys are displayed:



11 Press and set:

- All Math: **On**

12 Press the **Statistics** softkey:

- The **Statistics** softkeys are displayed:



13 Press to set:

- Statistics: **On**
- The display shows:

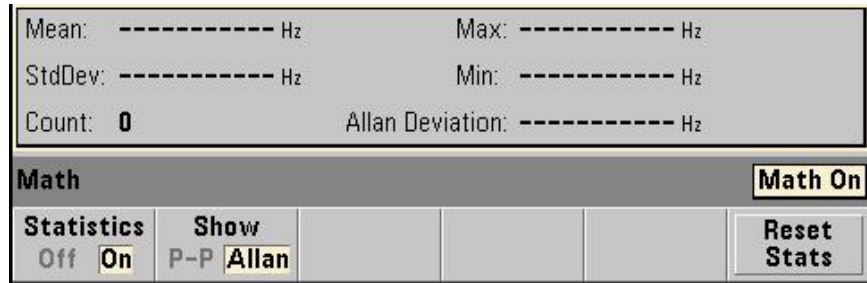

Single period test procedure

- 1** Press the **Trigger** key.
 - Counter takes 100 readings and fills in Math functions.
- 2** Verify the 'Mean' is:
 - 1.00 uSec \pm 0.200 nSec (53220A)
 - 1.00 uSec \pm 0.100 nSec (53230A)
- 3** Verify the 'Std Dev' is less than:
 - 0.140 nSec (53220A)
 - 0.028 nSec (53230A)
- 4** Record the 'Mean' and 'Std Dev' for 1 MHz, Channel 1, Test 3a, in the Keysight 53220A/53230A Performance Test Record starting on [page 90](#).
- 5** Press the **Reset Stats** softkey.
- 6** Set the CG635 output frequency to 250 MHz.
- 7** Press the **Trigger** key.
 - Counter takes 100 readings and fills in Math functions.

- 8** Verify the 'Mean' is:
 - 4.00 nSec \pm 0.200 nSec (53220A)
 - 4.00 nSec \pm 0.100 nSec (53230A)
- 9** Verify the 'Std Dev' is less than:
 - 0.140 nSec (53220A)
 - 0.028 nSec (53230A)
- 10** Record the 'Mean' and 'Std Dev' for 250 MHz, Channel 1, Test 3b, in the Keysight 53220A/53230A Performance Test Record starting on [page 90](#).
- 11** Press the **Reset Stats** softkey.
- 12** Repeat steps 1 to 11 for Channel 2. Be sure to perform the Channel 2 setup (see steps 6 and 7 under "Counter Setup".)

NOTE

Selecting Channel 2 automatically resets the statistics.

-
- 13** Record the 'Mean' and 'Std Dev' for 1 MHz and 250 MHz, Channel 2, Test 3c and 3d, in the Keysight 53220A/53230A Performance Test Record starting on [page 90](#).
 - 14** Press the **Reset Stats** softkey.
 - 15** Proceed to Test #4 or disconnect the setup.

Test 4: (Q) Pulse width

This test uses the Keysight 53220A/53230A Counter to measure the width of a narrow pulse from a pulse generator.

NOTE

Test #4 applies to the 53220A and 53230A only.

Equipment

- FS725 Rubidium timebase
- Keysight 81134A pulse generator
Keysight 10503 BNC cables (3)
- Keysight 15443A (SMA) cable or Keysight 11500E (3.5 mm) cable
- Keysight 1250-1200 BNC(f)-to-SMA(m) adapter (2)

81134A setup

- Output Level: **1 Vpp**
- Period: **66.6 nSec**
- Pulse Width: **5 nSec**

Counter setup

- 1 Connect the equipment as shown in [Figure 1-6](#).

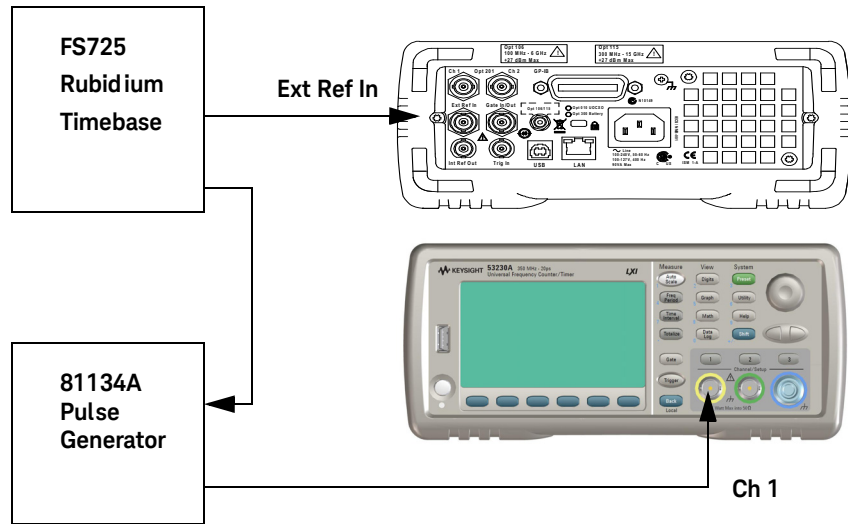

Figure 1-6 Pulse width test setup

- 2 Press the **Preset** key to preset the counter.
 - Display shows:
 - **Instrument has been preset.**
 - **Ext Ref** is shown in the upper right-hand corner of the display.
- 3 Press the **Time Interval** key.
 - The following softkeys are displayed:



- 4 Press the **Pulse Width** softkey.
- The following softkeys are displayed:



- 5 Press and set:
- Set width: **pos**
 - auto level: **Off**
 - Input level: **+0.00 V**
 - Set noise rejection: **Off**
- 6 Press the **Trigger** key.
- Front panel display shows:



- 7 Press and set:
- Source: **Manual**
 - **Wait For Trig** is displayed
 - Rdgs/Trigger: **100**
 - Trig Delay: **0** Seconds

1 Performance Tests

8 Press the Channel 1 key:

- The Channel 1 Setup softkeys are displayed:

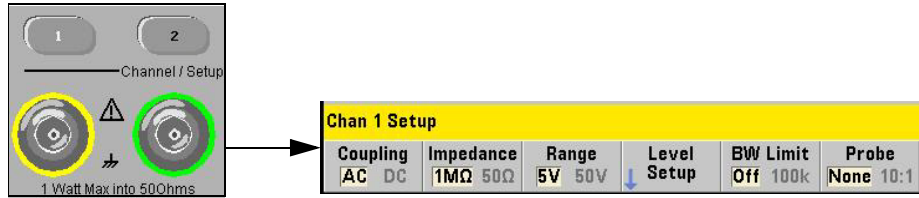

9 Press and set:

- Coupling: **DC**
- Input Impedance: **50 Ω**
- Range: **5 V**
- BW Limit: **OFF**

10 Press the **Math** key.

- The following softkeys are displayed:



11 Press and set:

- All math: **On**

12 Press the **Statistics** softkey:

- The **Statistics** softkeys are displayed:



13 Press to set:

- Statistics: **On**
- The display shows:

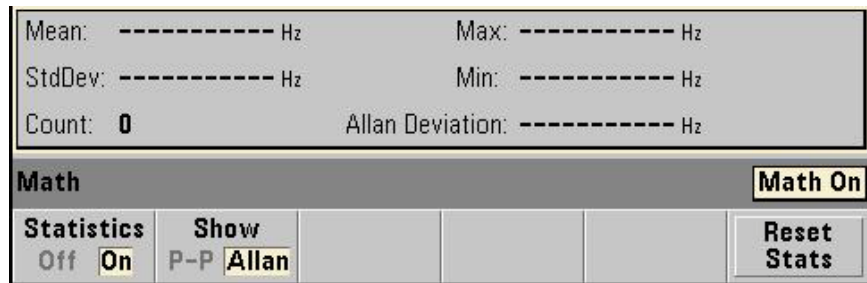

Pulse width test procedure

- 1** Press the **Trigger** key.
 - Counter takes 100 readings and fills in Math functions.
- 2** Verify the 'Mean' is:
 - 5 ± 0.4 nSec (53220A)
 - 5 ± 0.2 nSec (53230A)
- 3** Verify the 'Std Dev' is less than:
 - 0.140 nSec (53220A)
 - 0.028 nSec (53230A)
- 4** Record the Mean and Standard Deviation for Channel 1, Test 4a, in the ["Keysight 53210A/53220A/53230A Performance Test Record \(Tests 1 to 7\)"](#) on page 90.
- 5** Repeat steps 1 to 3 for Channel 2 (Test 4b). Be sure to do the Channel 2 setup first. (See steps 8, 9 in the Counter setup above.)

NOTE

Selecting Channel 2 automatically resets the statistics.

1 Performance Tests

- 6 Record the Mean and Standard Deviation for Channel 2, Test 4b, in the “[Keysight 53210A/53220A/53230A Performance Test Record \(Tests 1 to 7\)](#)” on page 90.
- 7 Proceed to Test #5 or disconnect the test setup.

Test 5: (Q) Time interval

This test verifies the time interval specifications between Channel 1 and Channel 2.

NOTE

Test #5 applies to the 53220A and 53230A only.

Equipment

- FS725 Rubidium timebase
- Keysight 81134A pulse generator
- Keysight 10503 BNC cables (2)
- Keysight 11500E (3.5) mm cables (2)
- Keysight 1250-1200 BNC(f)-to-SMA(m) adapter

NOTE

The 3.5 mm cables must be the exact same length or erroneous measurements will occur.

81134A setup

- Output Level: **1 Vpp**
- Period: **66.6 nSec**
- Pulse Width Ch1: **5 nSec**
- Pulse Width Ch2: **5 nSec**
- Delay Ch2: **49.9 nSec**

Counter setup

- 1 Connect the equipment as shown in [Figure 1-7](#).

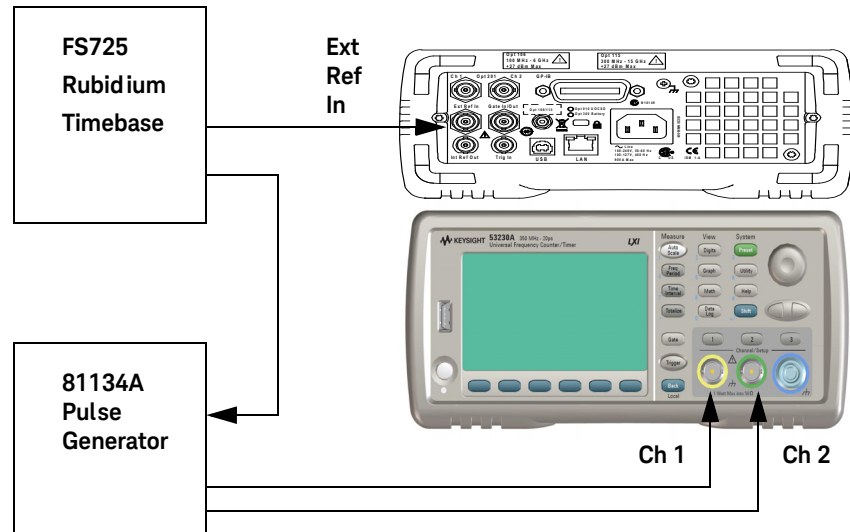

Figure 1-7 Time interval (channel 1 to 2) test setup

- 2 Press the **Preset** key to preset the counter.
 - Display shows:
 - **Instrument has been preset.**
 - **Ext Ref** is shown in the upper right-hand corner of the display.
- 3 Press the **Time Interval** key.
 - The following softkeys are displayed:



- 4 Press the **Time Interval** softkey.

1 Performance Tests

- The **Time Interval** softkeys are displayed:



- 5 Press to set **Time Int: 1-2**.

NOTE

Time Int 2-1 could also be tested, but only one test is required. If **Time Int 2-1** is used, set the 81134A to delay Channel 1 by 49.9 nSec instead of Channel 2.

- 6 Press the **Start Ch Level** softkey.
- 7 The following softkeys are displayed:



- 8 Press and set:
 - Slope: **Pos**
 - Auto Level: **Off**
 - Level: **0 V**
 - Noise Rej: **Off**
- 9 Press the **Back** key.
- 10 Press the **Stop Ch Level** softkey.
- 11 Press and set:
 - Slope: **Pos**
 - Auto Level: **Off**
 - Level: **0 V**
 - Noise Rej: **Off**

- 12** Press the **Trigger** key.
- Front panel display shows:



- 13** Press to set:
- Source: **Manual**
 - **Wait For Trig** is displayed
 - Rdgs/Trigger: **100**
 - Trig Delay: **0 seconds**
- 14** Press the **Math** key.
- The following softkeys are displayed:



- 15** Press and set:
- All Math: **On**

16 Press the **Statistics** softkey:

- The **Statistics** softkeys are displayed:



17 Press to set:

- Statistics: **On**

The display shows:



Time interval test procedure

1 Press the **Trigger** key.

- The counter takes 100 readings and fills in the math functions.

2 Verify the 'Mean' is:

- 49.9 ± 0.5 nSec (53220A)
- 49.9 ± 0.25 nSec (53230A)

3 Verify the 'Std Dev' is less than:

- 0.140 nSec (53220A)
- 0.028 nSec (53230A)

4 Record the Median and Standard Deviation, Test 5, in the ["Keysight 53210A/53220A/53230A Performance Test Record \(Tests 1 to 7\)"](#) on page 90.

5 Proceed to Test #6 or disconnect the test setup.

Test 6a: (Q) Frequency accuracy - channel 2/3, option 106 (6 GHz microwave channel)

This test verifies the frequency accuracy of Option 106 Channel 2 (53210A) or Channel 3 (53220A/53230A) at two frequencies (100 MHz and 5.88 GHz).

Equipment

- FS725 Rubidium timebase
- Keysight E8257D-520 microwave signal generator
- Keysight 10503A BNC cable (2)
- Keysight 11500E (3.5) mm cable
- Keysight 1250-1250 N(M) to SMA(F)

E8257D-520 setup

- Output Frequency: **100 MHz**
- Output Power: **-27 dBm**

NOTE

The input power **MUST** be -27 ± 0.5 dBm at the channel 3 input connector. If necessary, use a 3.5 mm cable with certified loss at 100 MHz or a power meter to verify input power.

Counter setup

- 1 Press the **Preset** key to preset the counter.
- 2 Connect the equipment as shown in **Figure 1-8**.

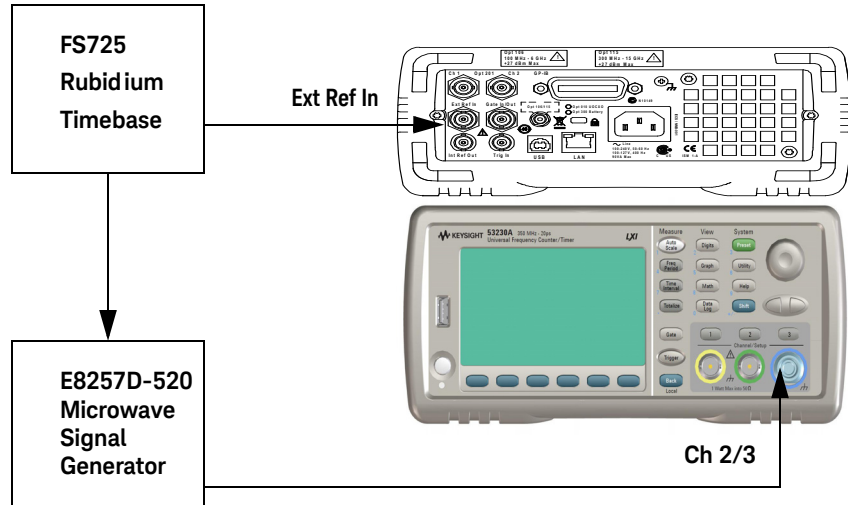
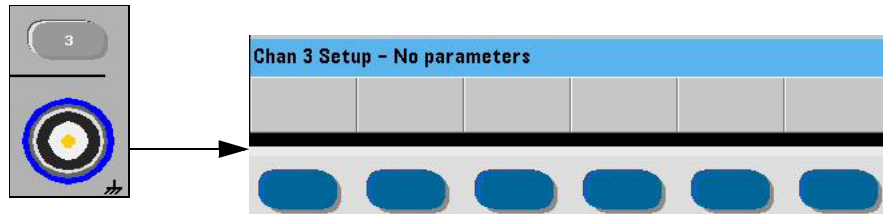

Figure 1-8 Option 106 (6 GHz) microwave channel 2/3 test setup

NOTE

For the Keysight 53210A Counter, Option 106 is installed as Channel 2. For the Keysight 53220A and 53230A Counters, Option 106 is installed as Channel 3. For this procedure, “Channel 3” is used to refer to the microwave input channel.

- 3 Press the Channel **3** input key.
 - Channel 3 is selected for test input.

**NOTE**

There are no parameters to set for Channel 3 for this test.

- 4 Press the **Gate** key.
 - The **Gate** softkeys are displayed:



- 5 Press and set:
 - Gate Src: **Timed**
 - Gate Out: **On**
 - Gate Time: **10 mSec**
- 6 Press the **Trigger** key.
 - The **Trigger** softkeys are displayed:



1 Performance Tests

7 Press to set:

- Source: **Manual**
 - **Wait For Trig** is displayed
- Rdgs/Trigger: **100**
- Trig Delay: **0 seconds**

8 Press the **Math** key.

- The **Math** softkeys are displayed:



9 Press to set:

- All Math: **On**

10 Press the **Statistics** softkey:

- The **Statistics** softkeys are displayed:



- 11** Press to set:
- Statistics: **On**
 - The display shows:

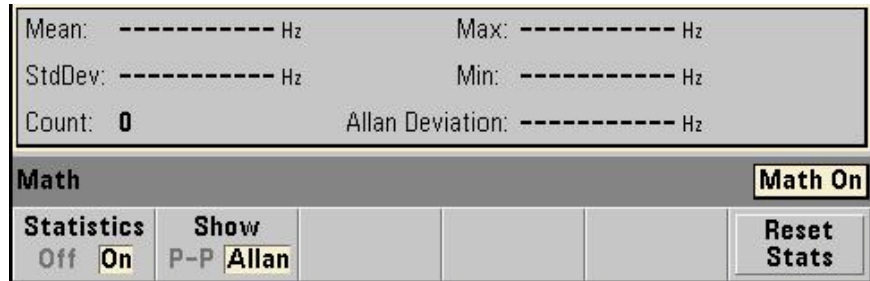

Channel 3 (option 106) frequency accuracy test procedure

- 1** Press the **Trigger** key.
 - The counter takes 100 readings and fills in the math functions.
- 2** Verify the 'Mean' is:
 - 100 MHz \pm 1.000 Hz (53210A)
 - 100 MHz \pm 100 mHz (53220A/53230A)
- 3** Verify the 'Std Dev' is less than:
 - 1.400 Hz (53210A)
 - 700 mHz (53220A)
 - 140 mHz (53230A)
- 4** Record the Mean and Standard Deviation for 100 MHz, Test 6a, in the Keysight 53210A/53220A/53230A Performance Test Record.
- 5** Press the **Reset Stats** softkey.
- 6** Set the E8257D-520 to 5.88 GHz at -27 dBm.

NOTE

The input power **MUST** be -27 ± 0.5 dBm at the channel 3 input connector. If necessary, use a 3.5 mm cable with certified loss at 5.88 GHz or a power meter to verify input power.

1 Performance Tests

- 7** Press the **Trigger** key.
 - The counter takes 100 readings and fills in the math functions.
- 8** Verify the 'Mean' is:
 - 5.88 GHz \pm 58.800 Hz (53210A)
 - 5.88 GHz \pm 5.880 Hz (53220A/53230A)
- 9** Verify the 'Std Dev' is less than:
 - 82.300 Hz (53210A)
 - 41.100 Hz (53220A)
 - 8.230 Hz (53230A)
- 10** Record the Mean and Standard Deviation for 5.88 GHz, Test 6a, in the Keysight 53210A/53220A/53230A Performance Test Record.
- 11** Press the **Reset Stats** softkey.
- 12** If Opt 150 is installed, proceed to Test 7a. Otherwise, disconnect the test setup.

Test 6b: (Q) Frequency accuracy - channel 2/3, option 115 (15 GHz microwave channel)

This test verifies the frequency accuracy of Option 115 Channel 2 (53210A) or Channel 3 (53220A/53230A) at three frequencies (300 MHz, 3.1 GHz, and 15.0 GHz).

Equipment

- FS725 Rubidium timebase
- Keysight E8257D-520 microwave signal generator
- Keysight 10503A BNC cable (2)
- Keysight 11500E (3.5) mm cable
- Keysight 1250-1250 N(M) to SMA(F)

E8257D-520 setup

- Output Frequency: **300 MHz**
- Output Power: **-23 dBm**

NOTE

The input power **MUST** be -23 ± 0.5 dBm at the channel 3 input connector. If necessary, use a 3.5 mm cable with certified loss at 300 MHz or a power meter to verify input power.

Counter setup

- 1 Press the **Preset** key to preset the counter.
- 2 Connect the equipment as shown in **Figure 1-9**.

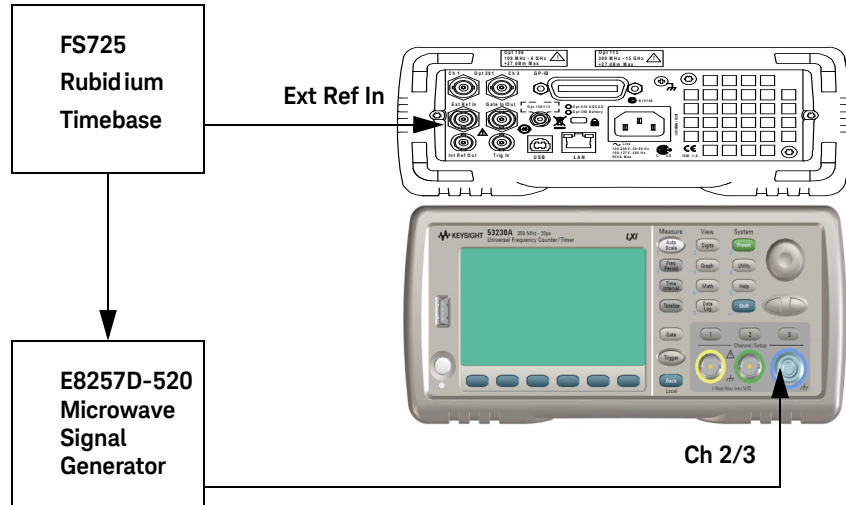
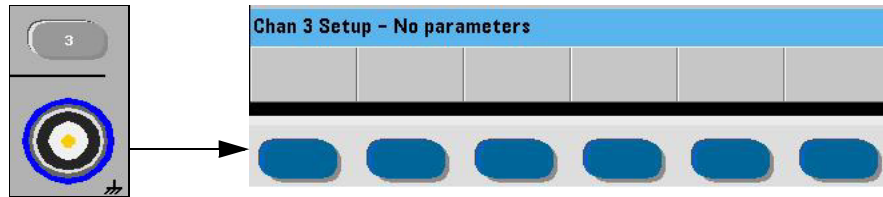

Figure 1-9 Option 115 (15 GHz) microwave channel 2/3 test setup

NOTE

For the Keysight 53210A Counter, Option 115 is installed as Channel 2. For the Keysight 53220A and 53230A Counters, Option 115 is installed as Channel 3. For this procedure, “Channel 3” is used to refer to the microwave input channel.

- 3 Press the Channel **3** input key.
 - Channel 3 is selected for test input.

**NOTE**

There are no parameters to set for Channel 3 for this test.

- 4 Press the **Gate** key.
 - The **Gate** softkeys are displayed:



- 5 Press and set:
 - Gate Src: **Timed**
 - Gate Out: **On**
 - Gate Time: **10 mSec**
- 6 Press the **Trigger** key.
 - The **Trigger** softkeys are displayed:



1 Performance Tests

- 7** Press to set:
- Source: **Manual**
 - **Wait For Trig** is displayed
 - Rdgs/Trigger: **100**
 - Trig Delay: **0 seconds**
- 8** Press the **Math** key.
- The **Math** softkeys are displayed:



- 9** Press to set:
- All Math: **On**
- 10** Press the **Statistics** softkey:
- The **Statistics** softkey menu is displayed:



- 11** Press to set:
- Statistics: **On**
 - The display shows:

Mean: ----- Hz	Max: ----- Hz
StdDev: ----- Hz	Min: ----- Hz
Count: 0	Allan Deviation: ----- Hz
Math	
Math On	
Statistics	Show
Off On	P-P Allan
Reset Stats	

Channel 3 (option 115) frequency accuracy test procedure

- 1** Press the **Trigger** key.
 - The counter takes 100 readings and fills in the math functions.
- 2** Verify the 'Mean' is:
 - 300 MHz \pm 3.0 Hz (53210A)
 - 300 MHz \pm 0.3 Hz (53220A/53230A)
- 3** Verify the 'Std Dev' is less than:
 - 4.2 Hz (53210A)
 - 2.1 Hz (53220A)
 - 0.42 Hz (53230A)
- 4** Record the Mean and Standard Deviation for 300 MHz, Test 6b, in the Keysight 53210A/53220A/53230A Performance Test Record.
- 5** Press the **Reset Stats** softkey.
- 6** Set the E8257D-520 to 3.1 GHz at -27 dBm.

NOTE

The input power **MUST** be -27 ± 0.5 dBm at the channel 3 input connector. If necessary, use a 3.5 mm cable with certified loss at 3.1 GHz or a power meter to verify input power.

- 7** Press the **Trigger** key.
 - The counter takes 100 readings and fills in the math functions.

- 8** Verify the 'Mean' is:
 - 3.1 GHz \pm 31 Hz (53210A)
 - 3.1 GHz \pm 3.1 Hz (53220A/53230A)
- 9** Verify the 'Std Dev' is less than:
 - 43.4 Hz (53210A)
 - 21.7 Hz (53220A)
 - 4.34 Hz (53230A)
- 10** Record the Mean and Standard Deviation for 3.1 GHz, Test 6b, in the Keysight 53210A/53220A/53230A Performance Test Record.
- 11** Press the **Reset Stats** softkey.
- 12** Set the E8257D-520 to 15.0 GHz at -4 dBm.

NOTE

The input power **MUST** be -4 ± 0.5 dBm at the channel 3 input connector. If necessary, use a 3.5 mm cable with certified loss at 15 GHz or a power meter to verify input power.

- 13** Press the **Trigger** key.
 - The counter takes 100 readings and fills in the math functions.
- 14** Verify the 'Mean' is:
 - 15.0 GHz \pm 150 Hz (53210A)
 - 15.0 GHz \pm 15 Hz (53220A/53230A)
- 15** Verify the 'Std Dev' is less than:
 - 210 Hz (53210A)
 - 105 Hz (53220A)
 - 21.0 Hz (53230A)
- 16** Record the Mean and Standard Deviation for 15.0 GHz, Test 6b, in the Keysight 53210A/53220A/53230A Performance Test Record.
- 17** Press the **Reset Stats** softkey.
- 18** If Opt 150 is installed, proceed to Test 7c. Otherwise, disconnect the test setup.

Test 7a: (Q) Pulse burst frequency - 53230A channel 3 option 150 with option 106

This test uses the 53230A to measure both narrow and wide pulse outputs of a 6 GHz carrier.

NOTE

This test procedure applies only to the 53230A Counter with Option 106 and Option 150 installed. Option 106 is installed as microwave channel 3.

NOTE

The Quick Verification (Q) requires only the Narrow Pulse Width Burst Frequency Test be performed.

Equipment

- FS725 Rubidium timebase
- Keysight E8257D-520-UNW microwave signal generator
- Keysight 10503A BNC cable (2)
- Keysight 11500E (3.5) mm cable
- Keysight 1250-1250 N(M) to SMA(F)

E8257D-520-UNW setup

- Output Frequency: **6 GHz**
- Output Power: **0 dBm**
- Auto-Level Control: **Off**
- Pulse Mode: **On**
- Pulse Repetition Interval Period: **1 mSec**
- Pulse Width (Narrow): **200 nSec**

NOTE

The input power **MUST** be 0 ± 0.5 dBm at the channel 3 input connector. If necessary, use a 3.5 mm cable with certified loss at 6 GHz or a power meter to verify input power.

Counter setup

- 1 Connect the equipment as shown in [Figure 1-10](#).

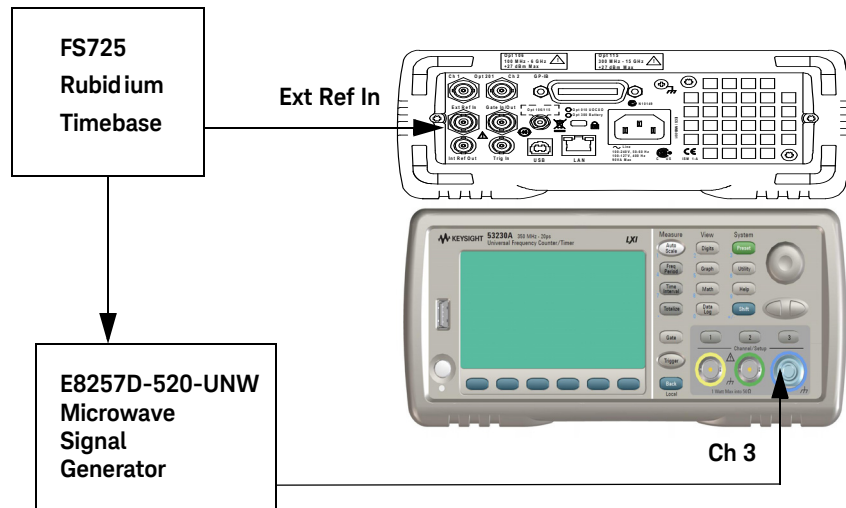
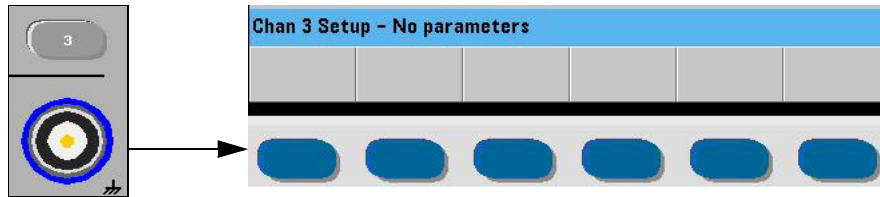

Figure 1-10 Option 106/150 microwave channel 3 test setup

- 2 Press the **Preset** key to preset the counter.
- 3 If needed, perform an Auto-Calibration. (Refer to "[Internal auto-calibration](#)" on page 27.)

- 4 Press the Channel **3** input key.
 - Channel 3 is selected for test input.

**NOTE**

There are no parameters to set for Channel 3 for this test.

- 5 Press the **Freq period** key.
 - The **Freq/Period** softkeys are displayed:



- 6 Press the **Pulse/Burst** softkey.
 - The **Pulse/Burst** menu softkeys are displayed:



1 Performance Tests

7 Press the **Burst Freq** softkey.

- The **Burst Freq** menu softkeys are displayed:



8 Press to select:

- dB Level: **-12**
- Narrow: **On**
- Gate Auto: **On**

9 Press the **Trigger** key.

- The **Trigger** softkeys are displayed:



10 Press to set:

- Source: **Manual**
 - **Wait For Trig** is displayed
- Rdgs/Trigger: **100**
- Trig Delay: **0 seconds**

11 Press the **Math** key.

- The **Math** softkeys are displayed:

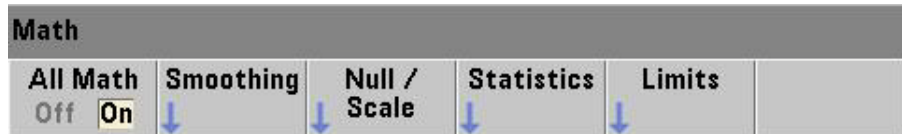

12 Press to set:

- All Math: **On**

13 Press the **Statistics** softkey:

- The **Statistics** softkeys are displayed:



14 Press to set:

- Statistics: **On**
- The display shows:

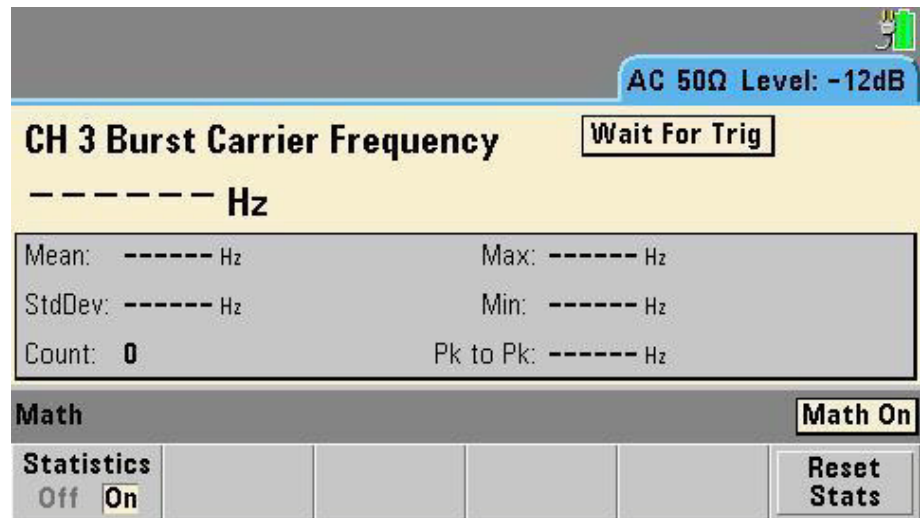

Channel 3 pulse burst frequency test procedure

- 1** Press the **Trigger** key.
 - The counter takes 100 readings and fills in the math functions.

1 Performance Tests

- 2 Verify the 'Mean' is:
 - 6 GHz \pm 6 MHz
- 3 Verify the 'Std Dev' is less than:
 - 3 MHz
- 4 Record the Mean and Standard Deviation for Test 7a, in the [“Keysight 53210A/53220A/53230A Performance Test Record \(Tests 1 to 7\)”](#) on page 90.
- 5 Press the **Reset Stats** softkey.

NOTE

For Quick Verification (Q), only the narrow pulse width burst frequency test needs to be performed.

- 6 Set the E8257D-520 to a pulse width of 13 uSec (Wide Pulse).
- 7 Press **[Freq/Period] / (Pulse/Burst) / (Burst Freq)** keys.
- 8 Press and set:
 - dB Level: **-6**
 - Narrow: **Off**
 - Gate Auto: **On**
- 9 Press the **Trigger** key.
 - The counter takes 100 readings and fills in the math functions.
- 10 Verify the 'Mean' is:
 - 6 GHz \pm 46 kHz
- 11 Verify the 'Std Dev' is less than:
 - 18.5 kHz
- 12 Record the Mean and Standard Deviation for Test 7b, in the [“Keysight 53210A/53220A/53230A Performance Test Record \(Tests 1 to 7\)”](#) on page 90.
- 13 Press the **Reset Stats** softkey.
- 14 Disconnect the test setup.

Test 7c: (Q) Pulse burst frequency - 53230A channel 3 option 150 with option 115

This test uses the 53230A to measure both narrow and wide pulse outputs of a 1.35 GHz carrier using the Opt 115 microwave channel.

NOTE

This test procedure applies only to the 53230A Counter with Option 115 and Option 150 installed. Option 115 is installed as microwave channel 3.

NOTE

The Quick Verification (Q) requires only the Narrow Pulse Width Burst Frequency Test be performed.

Equipment

- FS725 Rubidium timebase
- Keysight E8257D-520-UNW microwave signal generator
- Keysight 10503A BNC cable (2)
- Keysight 11500E (3.5) mm cable
- Keysight 1250-1250 N(M) to SMA(F)

E8257D-520-UNW setup

- Output Frequency: **1.35 GHz**
- Output Power: **-6 dBm**
- Auto-Level Control: **Off**
- Pulse Mode: **On**
- Pulse Repetition Interval Period: **1 mSec**
- Pulse Width (Narrow): **400 nSec**

Counter setup

- 1 Connect the equipment as shown in [Figure 1-11](#).

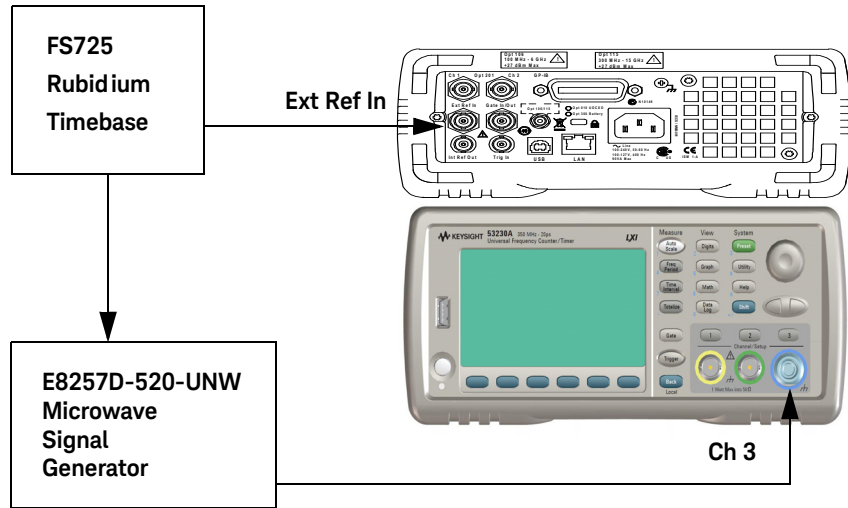
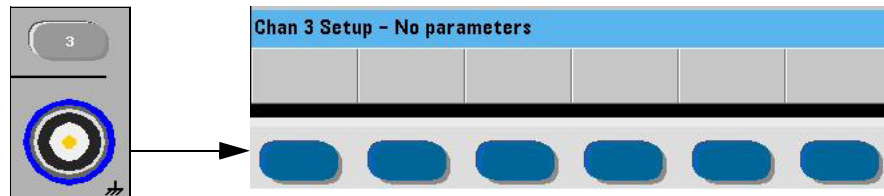

Figure 1-11 Option 115/150 microwave channel 3 test setup

- 2 Press the **Preset** key to preset the counter.
- 3 If needed, perform an auto-calibration. (Refer to [“Internal auto-calibration”](#) on page 27.)
- 4 Press the Channel **3** input key.
 - Channel 3 is selected for test input.



NOTE

There are no parameters to set for Channel 3 for this test.

- 5 Press the **Freq period** key.
- The **Freq/Period** softkeys are displayed:



- 6 Press the **Pulse/Burst** softkey.
- The **Pulse/Burst** menu softkeys are displayed:



- 7 Press the **Burst Freq** softkey.
- The **Burst Freq** menu softkeys are displayed:



- 8 Press to select:
 - dB Level: **-6**
 - Narrow: **On**
 - Gate Auto: **On**

- 9 Press the **Trigger** key.
- The **Trigger** softkeys are displayed:



- 10 Press to set:
- Source: **Manual**
 - **Wait For Trig** is displayed
 - Rdgs/Trigger: **100**
 - Trig Delay: **0 seconds**

- 11 Press the **Math** key.
- The **Math** softkeys are displayed:

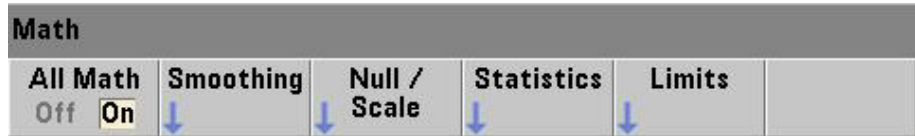

- 12 Press to set:
- All Math: **On**
- 13 Press the **Statistics** softkey:

- The **Statistics** softkeys are displayed:



- 14 Press to set:
- Statistics: **On**
 - The display shows:

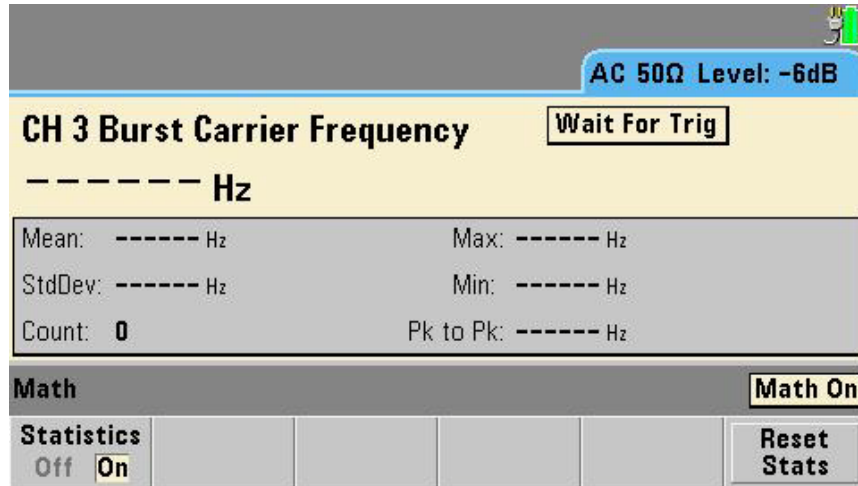

Channel 3 pulse burst frequency test procedure

- 1 Press the **Trigger** key.
 - The counter takes 100 readings and fills in the math functions.
- 2 Verify the 'Mean' is:
 - 1.35 GHz \pm 1.35 MHz
- 3 Verify the 'Std Dev' is less than:
 - 338 kHz
- 4 Record the Mean and Standard Deviation for Test 7c, in the [“Keysight 53210A/53220A/53230A Performance Test Record \(Tests 1 to 7\)”](#) on page 90?.
- 5 Press the **Reset Stats** softkey.

NOTE

For Quick Verification (Q), only the narrow pulse width burst frequency test needs to be performed.

- 6** Set the E8257D-520 to a pulse width of 13 uSec (Wide Pulse).
- 7** Press [**Freq/Period**] / (**Pulse/Burst**) / (**Burst Freq**) keys.
- 8** Press and set:
 - dB Level: **-6**
 - Narrow: **Off**
 - Gate Auto: **On**
- 9** Press the **Trigger** key.
 - The counter takes 100 readings and fills in the math functions.
- 10** Verify the 'Mean' is:
 - 1.35 GHz \pm 20.8 kHz
- 11** Verify the 'Std Dev' is less than:
 - 7.79 kHz
- 12** Record the Mean and Standard Deviation for Test 7d, in the [“Keysight 53210A/53220A/53230A Performance Test Record \(Tests 1 to 7\)”](#) on page 90.
- 13** Press the **Reset Stats** softkey.
- 14** Disconnect the test setup.

Keysight 53210A/53220A/53230A Operational Verification and Performance Test Record

Keysight Technologies Model 53210A/53220A/53230A Universal Counter

Model Number: _____

Serial Number: _____ Repair/Work Order No: _____

Test Performed By: _____ Temperature: _____

Date: _____ Relative Humidity: _____

Notes: _____

Test number	Operational verification	Test Results	
		Pass	Fail
1	Power on Test	<input type="checkbox"/>	<input type="checkbox"/>
2	Self-Test	<input type="checkbox"/>	<input type="checkbox"/>
3	Frequency Check, Channel 1, 10 MHz	<input type="checkbox"/>	<input type="checkbox"/>
4	Frequency Check, Channel 2, 10 MHz	<input type="checkbox"/>	<input type="checkbox"/>
5a	Termination Check Channel 1, 50W	<input type="checkbox"/>	<input type="checkbox"/>
5b	Termination Check Channel 1, 1MW	<input type="checkbox"/>	<input type="checkbox"/>
6a	Termination Check Channel 2, 50W	<input type="checkbox"/>	<input type="checkbox"/>
6b	Termination Check Channel 2, 1MW	<input type="checkbox"/>	<input type="checkbox"/>

Keysight 53210A/53220A/53230A Performance Test Record (Tests 1 to 7)

NOTE

(Q) under a test number indicates this is one of the 'quick' performance tests.

Complete performance tests				
Test number	Test description	Minimum	Actual reading	Maximum
1 (Q)	Absolute Timebase Test (Standard Timebase)	9.999 990 000 MHz	Record: Mean _____	10.000 010 000 MHz
1 (Q)	Absolute Timebase Test (Option 010, High Stability Timebase)	9.999 999 500 MHz	Record: Mean _____	10.000 000 500 MHz
2a (Q)	Channel 1 Frequency Accuracy Test		Record: Mean	
Keysight 53210A (only)	10 MHz Test	9.999 999 900 MHz	_____	10.000 000 100 MHz
	115 MHz Test	114.999 998 850 MHz	_____	115.000 001 150 MHz
	350 MHz Test	349.999 996 500 MHz	_____	350.000 003 500 MHz
			Record: Std Dev	
	10 MHz Test		_____	140.000 mHz
	115 MHz Test		_____	1 610.000 mHz
	350 MHz Test		_____	4 900.000 mHz

Complete performance tests				
Test number	Test description	Minimum	Actual reading	Maximum
2a (Q) Keysight 53220A (only)	Channel 1			
	Frequency Accuracy Test		Record: Mean	
	10 MHz Test	9.999 999 990 MHz	_____	10.000 000 010 MHz
	115 MHz Test	114.999 999 885 MHz	_____	115.000 000 115 MHz
	350 MHz Test	349.999 999 650 MHz	_____	350.000 000 350 MHz
			Record: Std Dev	
	10 MHz Test			70.000 000 mHz
	115 MHz Test		_____	805.000 000 mHz
	350 MHz Test		_____	2 450.000 000 mHz
2a (Q) Keysight 53230A (only)	Channel 1			
	Frequency Accuracy Test		Record: Mean	
	10 MHz Test	9.999 999 990 MHz	_____	10.000 000 010 MHz
	115 MHz Test	114.999 999 885 MHz	_____	115.000 000 115 MHz
	350 MHz Test	349.999 999 650 MHz	_____	350.000 000 350 MHz
			Record: Std Dev	
	10 MHz Test			14.000 000 mHz
	115 MHz Test		_____	161.000 000 mHz
	350 MHz Test		_____	490.000 000 mHz

1 Performance Tests

Complete performance tests				
Test number	Test description	Minimum	Actual reading	Maximum
2b (Q) Keysight 53220A (only)	Channel 2			
	Frequency Accuracy Test		Record: Mean	
	10 MHz Test	9.999 999 990 MHz	_____	10.000 000 010 MHz
	115 MHz Test	114.999 999 885 MHz	_____	115.000 000 115 MHz
	350 MHz Test	349.999 999 650 MHz	_____	350.000 000 350 MHz
			Record: Std Dev	
	10 MHz Test			70.000 000 mHz
	115 MHz Test		_____	805.000 000 mHz
	350 MHz Test		_____	2 450.000 000 mHz

2b (Q) Keysight 53230A (only)	Channel 2			
	Frequency Accuracy Test		Record: Mean	
	10 MHz Test	9.999 999 990 MHz	_____	10.000 000 010 MHz
	115 MHz Test	114.999 999 885 MHz	_____	115.000 000 115 MHz
	350 MHz Test	349.999 999 650 MHz	_____	350.000 000 350 MHz
			Record: Std Dev	
	10 MHz Test			14.000 000 mHz
	115 MHz Test		_____	161.000 000 mHz
	350 MHz Test		_____	490.000 000 mHz

Complete performance tests				
Test number	Test description	Minimum	Actual reading	Maximum
3	Single Period Test		Record: Mean	
Mean (53220A)			(53220A)	
a	Ch 1 - 1 MHz	0.999 800 000 uSec	a. _____	1.000 200 000 uSec
b	Ch 1 - 250 MHz	0.003 800 000 uSec	b. _____	0.004 200 000 uSec
c	Ch 2 - 1 MHz	0.999 800 000 uSec	c. _____	1.000 200 000 uSec
d	Ch 2 - 250 MHz	0.003 800 000 uSec	d. _____	0.004 200 000 uSec
3	Single Period Test		Record: Std Dev	
Std Dev (53220A)			(53220A)	
a	Ch 1 - 1 MHz		a. _____	.140 000 000 nSec
b	Ch 1 - 250 MHz		b. _____	.140 000 000 nSec
c	Ch 2 - 1 MHz		c. _____	.140 000 000 nSec
d	Ch 2 - 250 MHz		d. _____	.140 000 000 nSec
3	Single Period Test		Record: Mean	
Mean (53230A)			(53230A)	
a	Ch 1 - 1 MHz	0.999 900 000 uSec	a. _____	1.000 100 000 uSec
b	Ch 1 - 250 MHz	0.003 900 000 uSec	b. _____	0.004 100 000 uSec
c	Ch 2 - 1 MHz	0.999 900 000 uSec	c. _____	1.000 100 000 uSec
d	Ch 2 - 250 MHz	0.003 900 000 uSec	d. _____	0.004 100 000 uSec
3	Single Period Test		Record: Std Dev	
Std Dev (53230A)			(53230A)	
a	Ch 1 - 1 MHz		a. _____	.028 000 000 nSec
b	Ch 1 - 250 MHz		b. _____	.028 000 000 nSec
c	Ch 2 - 1 MHz		c. _____	.028 000 000 nSec
d	Ch 2 - 250 MHz		d. _____	.028 000 000 nSec

1 Performance Tests

Complete performance tests					
Test number	Test description	Minimum	Actual reading	Maximum	
4a (Q)	Pulse Width Test Ch 1 (53220A)	4.600 000 000 nSec	Record: Mean	5.400 000 000 nSec	
			Record: Std Dev		0.140 000 000 nSec
	Ch 1 (53230A)	4.800 000 000 nSec	Record: Mean	5.200 000 000 nSec	
			Record: Std Dev		0.028 000 000 nSec
	4b (Q)	Pulse Width Test Ch 2 (53220A)	4.600 000 000 nSec	Record: Mean	5.400 000 000 nSec
				Record: Std Dev	
Ch 2 (53230A)		4.800 000 000 nSec	Record: Mean	5.200 000 000 nSec	
			Record: Std Dev		0.028 000 000 nSec

Complete performance tests				
Test number	Test description	Minimum	Actual reading	Maximum
5 (Q)	Time Interval Test		Record: Mean	
	53220A	49.400 000 000 nSecs	_____	50.400 000 000 nSec
	53230A	49.650 000 000 nSecs	_____	50.150 000 000 nSec
			Record: Std Dev	
	53220A		_____	0.140 000 000 nSec
	53230A		_____	0.028 000 000 nSec
6a (Option 106) (Q)	Frequency Accuracy Channel 3 100 MHz			
	53210A		Record: Mean	
	53220A	99.999 999 000 MHz	_____	100.000 001 000 MHz
	53230A	99.999 999 900 MHz	_____	100.000 000 100 MHz
		99.999 999 900 MHz	_____	100.000 000 100 MHz
	53210A		Record: Std Dev	
53220A		_____	1 400.000 000 mHz	
53230A		_____	700.000 000 mHz	
		_____	140.000 000 mHz	

1 Performance Tests

Complete performance tests				
Test number	Test description	Minimum	Actual reading	Maximum
6a (Option 106)	Frequency Accuracy			
	Channel 3			
	5.88 GHz			
	(Q)			
	53210A		Record: Mean	
	53220A	5.879 999 941 200 GHz	_____	5.880 000 058 800 GHz
	53230A	5.879 999 994 120 GHz	_____	5.880 000 005 880 GHz
		5.879 999 994 120 GHz	_____	5.880 000 005 880 GHz
	53210A		Record: Std Dev	
	53220A		_____	82.300 000 000 Hz
	53230A		_____	41.100 000 000 Hz
			_____	8.230 000 000 Hz
6b (Option 115)	Frequency Accuracy			
	Channel 3			
	300 MHz			
	(Q)			
	53210A		Record: Mean	
	53220A	299.999 997 MHz	_____	300.000 003 MHz
	53230A	299.999 999 7 MHz	_____	300.000 000 3 MHz
		299.999 999 7 MHz	_____	300.000 000 3 MHz
	53210A		Record: Std Dev	
	53220A		_____	4.2 Hz
	53230A		_____	2.1 Hz
			_____	0.42 Hz

Complete performance tests				
Test number	Test description	Minimum	Actual reading	Maximum
6b (Option 115) (Q)	Frequency Accuracy Channel 3 3.1 GHz			
	53210A		Record: Mean	
	53220A	3.099 999 969 GHz	_____	3.100 000 031 GHz
	53230A	3.099 999 996 9 GHz	_____	3.100 000 003 1 GHz
		3.099 999 996 9 GHz	_____	3.100 000 003 1 GHz
	53210A		Record: Std Dev	
	53220A		_____	43.4 Hz
	53230A		_____	21.7 Hz
			_____	4.34 Hz
	6b (Option 115) (Q)	Frequency Accuracy Channel 3 15.0 GHz		
53210A			Record: Mean	
53220A		14.999 999 850 GHz	_____	15.000 000 150 GHz
53230A		14.999 999 985 GHz	_____	15.000 000 015 GHz
		14.999 999 985 GHz	_____	15.000 000 015 GHz
53210A			Record: Std Dev	
53220A			_____	210 Hz
53230A			_____	105 Hz
			_____	21 Hz
7a (Q) Option 106 Option 150 53230A		Pulse Burst Frequency (6 GHz)	5.994 000 000 GHz	Record: Mean
	Narrow Pulse Width (200 nSec)		Record: Std Dev	
			_____	3.000 MHz

1 Performance Tests

Complete performance tests				
Test number	Test description	Minimum	Actual reading	Maximum
7b Option 106 Option 150 53230A	Pulse Burst Frequency (6 GHz)	5.999 954 000 GHz	Record: Mean _____	6.000 046 000 GHz
	Wide Pulse Width (13 uSec)		Record: Std Dev _____	
7c (Q) Option 115 Option 150 53230A	Pulse Burst Frequency (1.35 GHz)	1.348 865 000 GHz	Record: Mean _____	1.351 350 000 GHz
	Narrow Pulse Width (400 nSec)		Record: Std Dev _____	
7d Option 115 Option 150 53230A	Pulse Burst Frequency (1.35 GHz)	1.349 979 200 GHz	Record: Mean _____	1.350 020 800 GHz
	Wide Pulse Width (13 uSec)		Record: Std Dev _____	

Keysight 53210A/53220A/53230A 350 MHz Universal Frequency
Counter/Timer
Assembly Level Service Guide

2 Service

Introduction	100	
Returning the Instrument to Keysight Technologies for Service		104
About the Keysight 53210A/53220A/53230A Calibration Menu		109
The Keysight 53210A/53220A/53230A Calibration Procedures		118
Pre-Troubleshooting Information	152	
Troubleshooting the Counter	160	
Error Messages	174	

Introduction

NOTE

Unless otherwise indicated, this manual applies to all serial numbers for the Keysight 53210A/53220A/53230A Counters.

This chapter provides service information for your Keysight 53210A, 53220A, and 53230A Counters. It is divided into five major sections:

Returning the counter to Keysight Technologies for service

This section provides you with instructions on how to return the counter to Keysight for service.

About the Keysight 53210A/53220A/53230A calibration menu

This section contains reference information that gives an overview of the calibration menu for the Keysight 53210A, 53220A, and 53230A Counters.

The Keysight 53210A/53220A/53230A calibration procedures

This section provides step-by-step procedures for calibrating the Keysight 53210A, 53220A, and 53230A Counters.

Pre-troubleshooting information

This section provides you with pertinent information such as safety considerations, recommended test equipment, repair and after-service calibration considerations, and assembly identification and location.

Troubleshooting information

This section provides you with troubleshooting procedures that can assist you to isolate an instrument failure to the faulty assembly or module. A final section on “Error Messages” can be used to help isolate a failed assembly for replacement.

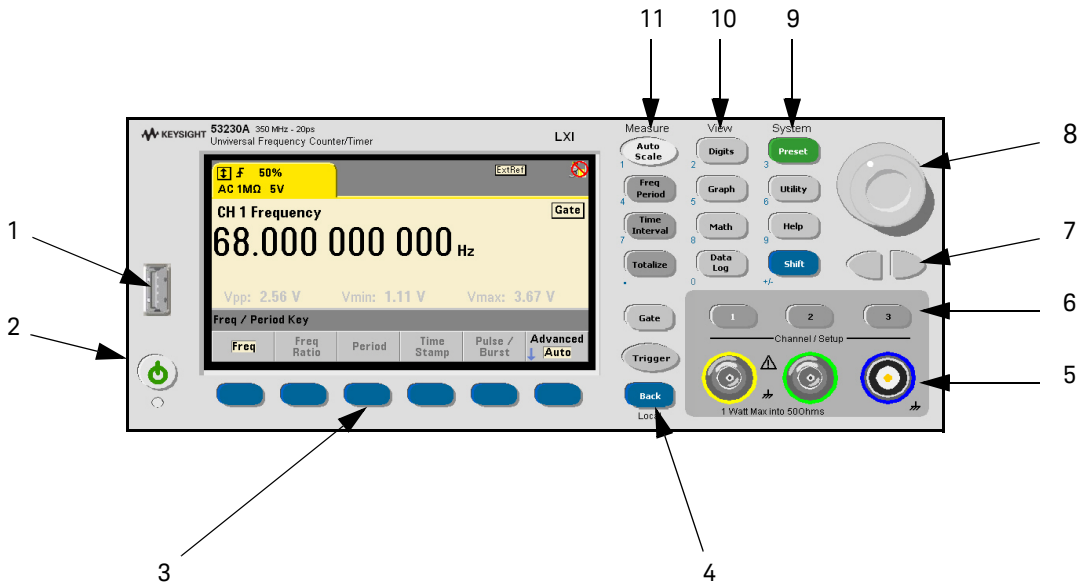

Figure 2-1 The front panel at a glance

- 1 USB Port
- 2 On / Standby Switch
- 3 Menu Softkeys
- 4 Back / Local Key
- 5 Channel Input Connectors
- 6 Channel Input Keys
- 7 L-R / Cursor Keys
- 8 Knob
- 9 System Keys
- 10 View Keys
- 11 Measure Keys

NOTE

The annunciator readout above each of the six softkeys identifies the function or action that will be performed when the softkey underneath that readout is pressed. (See [Figure 2-1](#) and [Figure 2-2](#).)

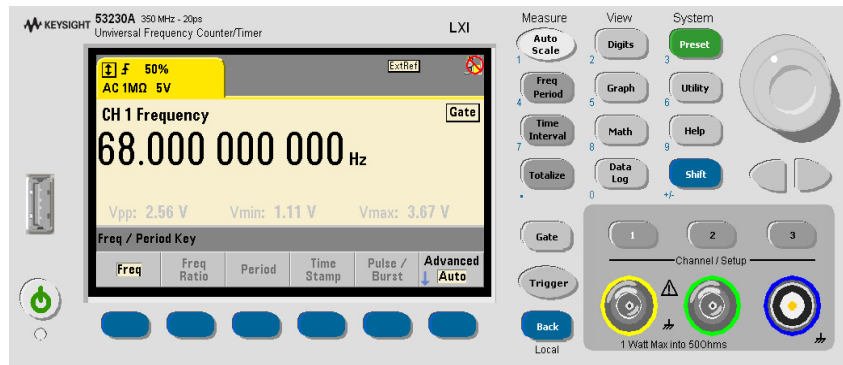

Figure 2-2 Front panel display

NOTE

For the purpose of discussion, in this chapter, a **[key]** refers to a push-button on the right-hand side of the front panel of the counter. A **(softkey)** refers to one of the six pushbutton functions beneath the display area. Softkeys may have any one of many different functions, depending upon which menu has been selected. A row of screen annunciators (softkey labels) will appear above the softkeys. A sample series of key depressions might be: **[Utility] / (Cal AutoCal) / enter <code> / (Unlock Cal)**

NOTE

If the counter is under warranty, refer to **“Returning the Instrument to Keysight Technologies for Service”** on page 104.

NOTE

If you decide to troubleshoot the instrument yourself, refer to the section titled “**Pre-Troubleshooting Information**” on page 152.

CAUTION

DO NOT swap the motherboard, the processor board, or the front panel board from one instrument to another. These boards contain model number and serial number information that uniquely identifies a specific unit, and boards that are mismatched to the instrument may result in problems with performance, calibration, licensing, serviceability, importability/exportability or warranty.

Returning the Instrument to Keysight Technologies for Service

Operating checklist

Before returning your instrument to Keysight Technologies for service or repair, check the following items:

Is the instrument inoperative?

- Verify that the AC power cord is connected to the instrument and an AC outlet.
- Verify that the front-panel **On/Standby** switch has been pushed. The power LED should be lit and not blinking.

Does the instrument fail self-test?

Remove all external connections to the instrument. Errors may be induced by signals present on the external connectors during a self-test. Long test leads, even leads that are otherwise unconnected, can act as an antenna causing pick-up of AC signals.

Types of service available

If your instrument fails during the warranty period, Keysight Technologies will repair or replace it under the terms of your warranty. After your warranty expires, Keysight offers repair services at competitive prices.

Extended service contracts

Many Keysight products are available with optional service contracts that extend the covered period after the standard warranty expires. If you have such a service contract and your instrument fails during the covered period, Keysight Technologies will repair or replace it in accordance with the contract.

Obtaining repair service (worldwide)

To obtain service for your instrument (in-warranty, under service contract, or post-warranty), contact your nearest Keysight Technologies Service Center as shown at the front of this service guide. They will arrange to have your unit repaired or replaced, and can provide warranty or repair-cost information where applicable.

To obtain warranty, service, or technical support information you can contact Keysight Technologies at one of the following telephone numbers:

- In the United States: (800) 829-4444
- In Europe: 31 20 547 2111
- In Japan: 0120-421-345

Or use our Web link for information on contacting Keysight worldwide:

- www.keysight.com/find/assist

Or contact your Keysight Technologies Representative.

Before shipping your instrument, ask the Keysight Technologies Service Center to provide shipping instructions, including what components to ship. Keysight recommends that you retain the original shipping carton for use in such shipments.

To provide repair information

If you are shipping the instrument to an Keysight Technologies office for service or repair, call your nearest Keysight Technologies Sales Office to make arrangements. Then tag and package the Keysight 53210A/53220A/53230A Counter for shipment.

Note there is an Express Repair/Performance Calibration Service for USA customers if downtime is critical. You can receive your repaired counter via overnight shipment. Just call 800-403-0801 and ask for Express Repair/Performance Calibration Service. When your counter is repaired, it will be returned via overnight shipment at no extra charge.

- 1** Write the following information on a tag:
 - Owner's name and address
 - Instrument model number
 - Complete serial number
 - Description of service required or failure indications
- 2** Attach the tag to the instrument.
- 3** Pack the instrument.

If you have the original packaging materials, refer to the following section titled **"To pack in the original packaging materials."** If the original packaging materials are not available, you can order new materials through an Keysight Technologies Sales Office. The new materials are identical to those used by the factory when packaging the instrument. If you want to use commercially available materials, refer to the section titled **"To pack in commercially available materials"** on page 107.

To pack in the original packaging materials

Whenever possible, repack the instrument in its original packaging for shipment. In any correspondence, refer to the instrument by the model number and complete serial number.

- Disconnect the power cord, probes, cables, or other accessories attached to the instrument.
- Make sure the folded corrugated spacer (which normally contains the manuals) is in the box to ensure proper fitting.
- Make sure one of the polystyrene blocks is in its proper position in the shipping box.
- Place the instrument, front panel end first, on the polystyrene block.
- Place the other polystyrene block on top of the rear end of the instrument to secure it. Seal the shipping container securely.
- Do not return the manuals with the instrument. Return an accessory only when it is a part of the failure symptoms.

To pack in commercially available materials

If the factory packaging materials are not available, you can use commercially available materials for shipping.

- Wrap the instrument in heavy paper or plastic.
- Place the instrument in a strong shipping container.
 - A double-wall carton made of 350-lb. test material is adequate.
- Protect the control panel with cardboard.
- Add a layer of shock-absorbing material.
 - The shock-absorbing material should be 70 to 100 mm (3 to 4 inches) thick around all sides of the instrument to prevent movement inside the container.
- Seal the shipping container securely.
- Mark the shipping container FRAGILE.

- To obtain warranty, service, or technical support information you can contact Keysight Technologies at one of the following telephone numbers:
 - In the United States: (800) 829-4444
 - In Europe: 31 20 547 2111
 - In Japan: 0120-421-345

If you have questions relating to the operation of the Keysight 53210A, 53220A, or 53230A Counters, call **1-800-452-4844** in the United States, or contact your nearest Keysight Technologies Sales Office as shown at the front of this service guide.

Warranty

If your 53210A/53220A/53230A Counter fails within the warranty period, Keysight will either repair or replace it free of charge. Call 1-877-447-7278 in the United States (and ask for “Keysight Express”) or contact your local Keysight Technologies Sales Office.

About the Keysight 53210A/53220A/53230A Calibration Menu

NOTE

If you are familiar with the information provided in this section, proceed to the section titled **“The Keysight 53210A/53220A/53230A calibration procedures”** on page 100 to calibrate your counter. This section, **“About the Keysight 53210A/53220A/53230A Calibration Menu,”** can be used as a reference. Your counter should be calibrated at least once each year to maintain specification accuracy.

Overview of the Keysight 53210A/53220A/53230A calibration menu

The Calibration menu is accessed by pressing the **Utility** key and then the **Cal / AutoCal** softkey. All of the calibration factors and security settings are stored in *non-volatile* memory, and *do not* change when power has been off or after a remote interface reset.

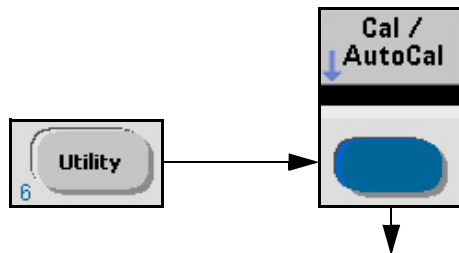

A calibration security code feature allows you to enter a security code (electronic key) to prevent accidental or unauthorized calibrations of the counter. The security code is set to AT53210A, AT53220A or AT53230A (corresponding to the model) when the counter is shipped from the factory. If you change, and then forget, your security code, you can reset the security code to a blank code by resetting all of the non-volatile memory to a default state. (Refer to the Procedure **“Resetting the security code to a null”** on page 151.) Then you can enter a new code.

The Calibration menu allows you to:

- **(Secure Code)** - View/change the calibration security status of the counter (Locked/Unlocked), or change/edit the secure password.
- **(Lock Cal)** - Secures against calibration by entering the displayed security code while the counter is unlocked.
- **(Unlock Cal)** - Unlocks the counter for a new calibration by entering the correct security code while the counter is locked.
- **(Perform Cal)** - Initiates the counter's calibration routines, which allow you to:
 - **(Cal Step)** - Select the type of calibration (frequency or voltage):
 - (Osc)** - Input the RF frequency for Channel 1 or Channel 2 frequency calibration.
 - (Positive Voltage)** - Calibrate, with an operator applied positive reference voltage, the internal DACs.
 - (Negative Voltage)** - Calibrate, with an operator applied negative reference voltage, the internal DACs.
 - (uWave)** - Input the calibration frequencies for the 6 GHz or 15 GHz microwave channel (Options 106 or 115).
 - (Perform Cal Step)** - Initiate the selected calibration step.
 - **(Measure Temp)** - Reads and displays the current temperature and also the temperature of the instrument during the last Auto-Cal.
 - **(Auto Cal)** - Performs an automatic calibration of the internal circuits of the counter. Does not require any external inputs. Same as the IEEE-488.2 command *CAL?.

NOTE

The Auto-Cal command is a subset of the routines executed in Self-Test (*TST). It is recommended that a counter Self-Test be performed before running any of the calibration routines. If the Self-Test passes, the calibration(s) may continue. If the counter fails the Self-Test, calibration should not be attempted until the counter is repaired and passes Self-Test. Refer to **“Troubleshooting the Counter”** on page 160.

NOTE

It is not necessary to unlock the counter to perform Auto-Cal. However, any signals routed to the Channel input connectors should be turned off or disconnected. Also, see the CAUTION below.

CAUTION

A successful ACAL will result in the automatic update of the compensation factors that a previous ACAL has measured and stored. Since ACAL changes these compensation factors, if there is a case where the user is making a measurement (or a series of sequential measurements) and doesn't want these compensation factors changed, the user may not want to run ACAL or Self Test.

To get help with the calibration menu functions

- 1 Press and hold any one of the calibration softkeys.
- 2 A message will be displayed with context-sensitive Help information.
 - Calibrate help is available for the following:
 - how to calibrate
 - how to secure the calibration routines
 - how to change the security code
 - how to enter the Cal String

NOTE

See [Figure 2-3](#) for a summary of the front panel calibration procedures.

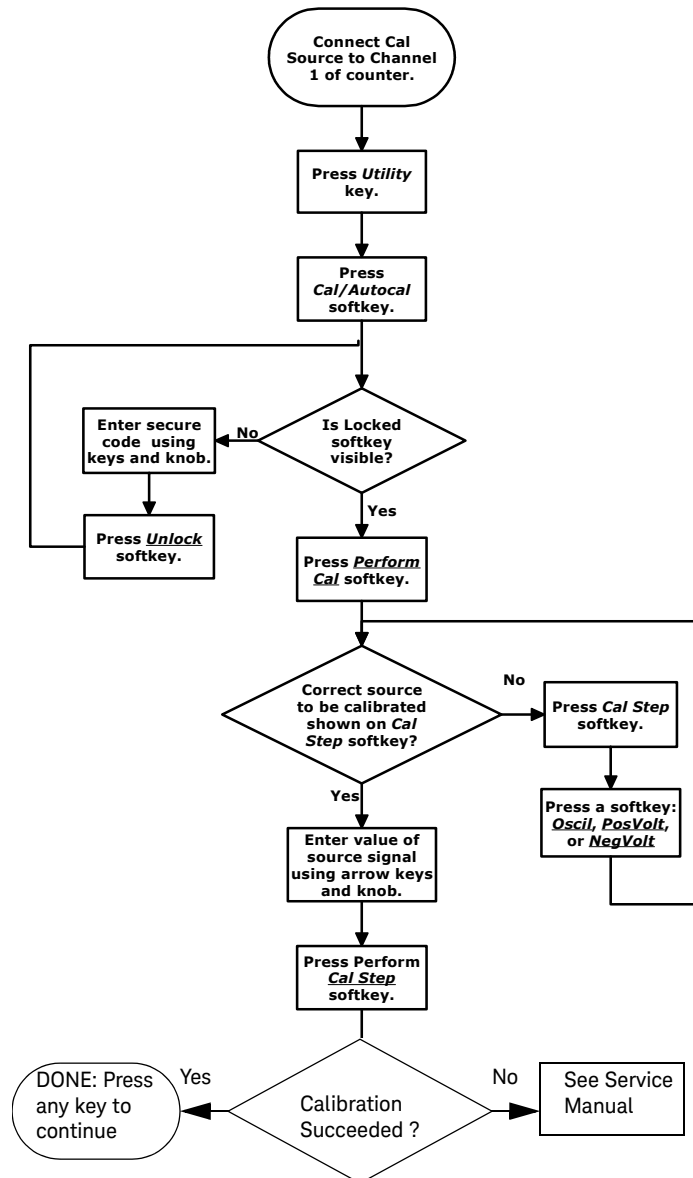
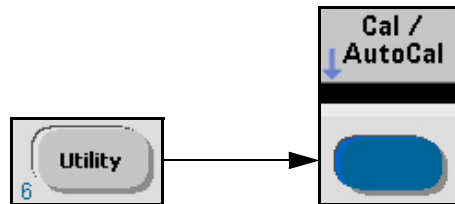

Figure 2-3 Calibration procedure summary

To view the calibration menu and security status from the counter front panel

- The Calibration Menu softkeys and pertinent “Calibrate Information” are accessed by pressing the **[Utility]** key and then the **(Cal / AutoCal)** softkey.



- The display shows the following:



- **Cal Count** shows the total number of times: (1) a successful calibration step has been completed; (2) calibration data is downloaded; (3) the Cal String or Secure Code is updated; (4) the counter firmware is updated. It is not operator-modifiable and rolls over at ($2^{32} - 1$). Since the unit is calibrated several times during manufacture, the Cal Count will not be zero when shipped.
- **Cal String** shows the current calibration string. This string is operator-modifiable, used to record such information as the date of the last calibration, or by whom it was performed. The Calibration String can not be entered from the front panel keys. It can only be entered/updated using the remote SCPI command: **CALibration STRing**. Refer to the Keysight 53210A/53220A/53230A SCPI Programmer's Reference for details of the command format.

- **Secure Code** displays either all dashes (---) or an operator-entered security code that has not yet been accepted by the counter.
- Display softkey annunciators show:



- If **"Unlock Cal"** is displayed for the second softkey from the left, the counter is locked against calibration. (See step 1.)
- If **"Lock Cal"** is displayed for the second softkey from the left, the counter is unlocked and ready for calibration.

To lock the counter against calibration

NOTE

When the counter security is locked to prevent unauthorized calibration, the **Unlock Cal** softkey is available. When the counter security is unlocked, the **Lock Cal** softkey replaces the **Unlock** softkey.

Display softkey annunciators show:

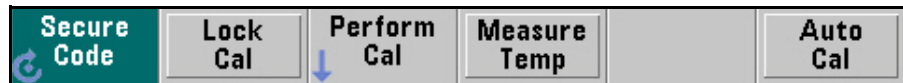

To lock the counter:

- 1 Using the front panel knob and right/left arrow keys, enter the current (or a new) security code in the data entry area (see [Figure 2-1](#) and [Figure 2-2](#)).
- 2 The characters available to use for the security code are selectable by rotating the knob on the front panel for each character position in the code:
 - A to Z, underline character, (_), and 0 to 9.

NOTE

The first character in the code **MUST** be a letter (A to Z).

CAUTION

IMPORTANT! Be sure to write down the calibration security code you enter before you lock the counter. Once the counter is locked, there is no way on the counter to tell what the code is. However, there is a procedure that can be used to reset the secure code to null so that a new code can be entered. Refer to **“Resetting the security code to a null”** on page 151.

- 3** When the code data entry is what you want, press the **Lock Cal** softkey to enter the data into the counter.
 - The data entry area and **Secure Code** areas change to all dash (--) characters when the code is accepted.
 - The **Lock Cal** softkey changes to **Unlock Cal**.
 - The **Cal Count** is incremented only if a new secure code was entered.

To unlock the counter for calibration:

- 1 Press the **Utility** key, and then press the **Cal/AutoCal** softkey.

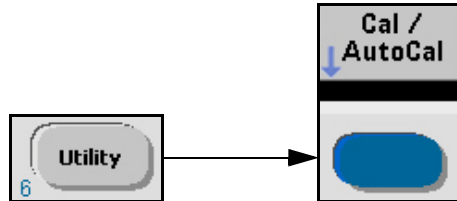

NOTE

If **Lock Cal** is displayed, then the counter is already unlocked for calibration, and the remaining steps are not applicable.

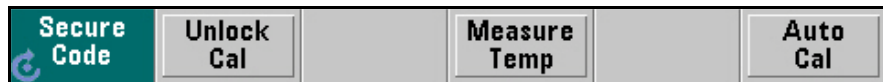

Unlock for calibration:

- 1 If **Unlock Cal** is displayed, use the counter front panel knob and the appropriate left/right arrow keys to enter a valid security code into the data entry field on the display (see [Figure 2-1](#) and [Figure 2-2](#)).
 - For example, if AT53210A was the security code set at the factory (for a 53210A Counter), then enter **AT53210A** into the data entry field. The code will repeat in the **Secure Code** line in the Calibrate Information screen.
- 2 Press the **Unlock Cal** softkey to complete the data entry.
 - If the code is valid, the **Unlock Cal** annunciator changes to **Lock Cal** to show the data was accepted and the counter is now unlocked for calibration.
 - The **Cal Count** is not incremented.
 - If “AT53210A” is NOT the correct security code, the counter will display:
 - **“Incorrect Security Code - Try Again”**

To change to a new security code

- 1 Unlock the counter by using the procedure described in the previous section titled “To Unlock The Counter For Calibration”.

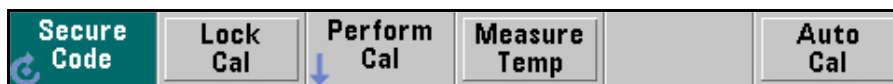

- 2 Enter a new security code and then press the **Lock Cal** softkey.

CAUTION

IMPORTANT! Be sure to write down the new calibration security code you enter before you lock the counter. Once the counter is locked, there is no way on the counter to tell what the code is. However, there is a procedure that can be used to reset the secure code to null so that a new code can be entered. Refer to **“Resetting the security code to a null”** on page 151 .

- The data entry area and **Secure Code** areas change to all dash (--) characters when the code is accepted.
- The **Cal Count** is incremented and the **Lock Cal** softkey changes to the **Unlock Cal** softkey.

The Keysight 53210A/53220A/53230A Calibration Procedures

Equipment required

Table 2-1 Recommended test equipment for calibration

Instrument	Required characteristics	Recommended model
10 MHz system clock or RF signal generator	10 MHz \pm 2.000E-12	Stanford Research Systems CG635 or equivalent
Primary frequency standard (10 MHz house standard)	Absolute accuracy $>1 \times 10^{-10}$	Stanford Research Systems FS725 Rubidium Timebase or equivalent
Digital multimeter (DMM)	Microvolt accuracy	Keysight 34410A or equivalent
Microwave signal generator	100 MHz to 15 GHz; Freq Accy at 6 GHz and 15 GHz: ± 10 ppb; PW Accy: $\pm 10\%$	Keysight E8257D-520-UNW or equivalent
DC power supply	Adjustable to ± 5.000 V	Keysight 6234A or equivalent
Type N(m)-to-BNC(f) Adapter		Keysight 1250-0780
SMA(m)-to-BNC(f) adapter		Keysight 1250-1200
BNC-to-dual banana plug	BNC(f) to banana plug(m)	Keysight E9637A or Newark 10M4161
50 Ohm coaxial cable with BNC connectors (5)	BNC(m) to BNC(m), 48 inches	Keysight 10503A
3.5mm cables	DC-18 GHz, matched pair	Keysight 11500E
Coaxial BNC tee connector		Keysight 1250-0781
Some of this equipment may no longer be available as new. Use an equivalent model number.		

NOTE

Whenever possible, the counter should be calibrated with the instrument oriented in the same physical direction in which it will be used (i.e. flat, on one side, or front panel facing up).

Determine the counter firmware version

- Press the **Help** key, then the **About** softkey.

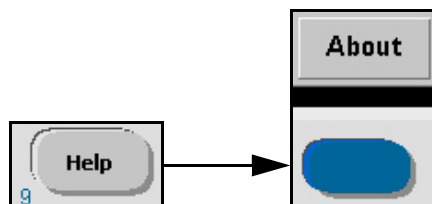

- An information screen (Figure 2-4) is displayed that contains the following items:
 - Keysight Model Number
 - Instrument Serial Number
 - IP and GPIB addresses
 - Firmware Version (Format: x.xx - x.xx - xx - xx - xx)
 - Installed Options

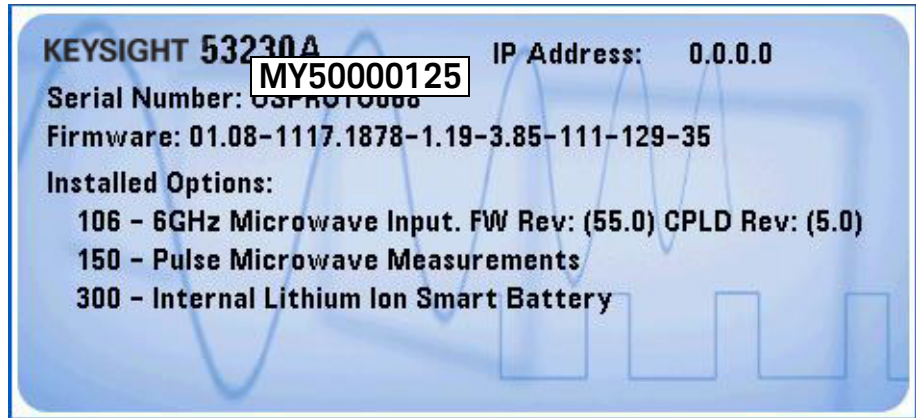

Figure 2-4 Information screen

NOTE

If any number less than 01.08 is displayed as the number before the first dash in the 'Firmware:' version, then refer to [Chapter 6, "Backdating"](#), for any possible changes to these calibration procedures for other firmware versions.

NOTE

If the counter's firmware version is equal to or higher than 01.08, then perform the procedures in this section.

NOTE

If Option 106 "6 GHz Microwave Input" is installed in your counter and the "FW Rev" is (27.0), refer to ["Procedure Changes"](#) on page 264 for information concerning the calibration procedure for your counter.

NOTE

After completing a new calibration of the counter, be sure to secure the stored calibration values by performing the procedure in the section titled ["To lock the counter against calibration"](#) on page 114.

Calibration cycle

The calibration cycle for the Keysight 53210A, 53220A, and 53230A Counters is 1-year. The counter should be calibrated at least once every 12 months to ensure specification accuracy.

Calibration string:

The **Cal String** on the **Calibrate Information** page is operator-modifiable and can be used to remotely enter any current or historical data/information up to 40 characters long. The string may include the characters A-Z, 0-9, and special characters like @, #, *, etc.

The **CAL STRing** can be entered remotely as follows:

- Send CALibration:STRing “<string>” .
- (Example:) output <address> ; CAL:STR “last cal 8-15-2010”
- CALibration:STRing? reads the current cal string contents from the counter:
 - “last cal 8-15-2010”

Internal reference oscillator calibration

- 1** First, run the counter Self-Test as described in “**Performing the counter self-test**” on page 169. A successful self-test procedure verifies that the counter is operational and ready for calibration.
- 2** Unlock the counter by performing the procedure “**To unlock the counter for calibration:**” on page 116. Key sequence:
[Utility] / (Cal AutoCal) / enter <code> / (Unlock Cal)
- 3** Set up a low-jitter, low-noise, external frequency source, such as the Stanford Research CG635, for a 10 MHz square wave at 1 Vpp, 0 volts offset, 50% duty cycle.

NOTE

If your source has an output enable feature, turn it ON.

- 4 Connect the frequency source (Q or not Q output) to Channel 1 on the counter front panel. See [Figure 2-5](#).

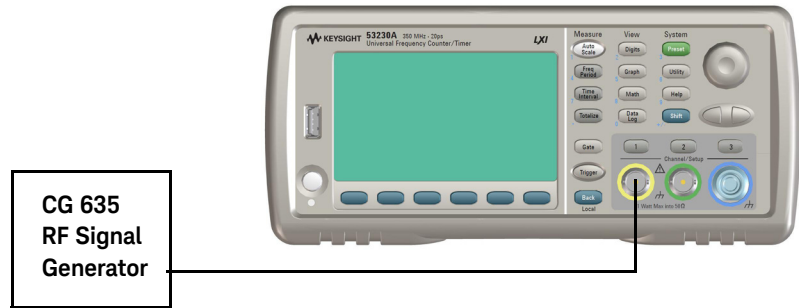
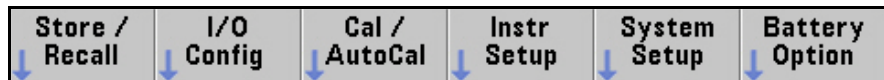

Figure 2-5 Oscillator calibration setup

- 5 Press the **Utility** key:



- Display softkey annunciators show:



6 Press the **Cal / AutoCal** softkey to display the calibrate options.

- Display softkey annunciators show:

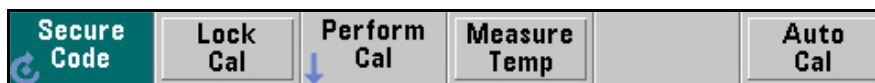

- The display shows:



- **Cal Count** shows the total number of times: (1) a successful calibration step has been completed; (2) calibration data is downloaded; (3) the Cal String or Secure Code is updated; (4) the counter firmware is updated. It is not operator-modifiable and rolls over at $(2^{32} - 1)$. Since the unit is calibrated several times during manufacture, the Cal Count will not be zero when shipped.
 - **Cal String** shows the current calibration string. This string is operator-modifiable, used to record such information as the date of the last calibration, or by whom it was performed. The Calibration String can not be entered from the front panel keys. It can only be entered/updated using the remote SCPI command: **CALibration STRing**. Refer to the Keysight 53210A/53220A/53230A SCPI Programmer's Reference for details of the command format.
 - **Secure Code** displays either all dashes (---) or an operator-entered security code that has not yet been accepted by the counter.
- 7 If "**Unlock Cal**" is displayed on a softkey, the counter is locked against calibration. (See step 2.)

8 If “**Lock Cal**” is displayed on a softkey, the counter is unlocked and ready for calibration.

- The **Perform Cal** softkey becomes available.

9 Press the **Perform Cal** softkey:

- The **Cal Step** softkey shows the last cal step that was selected:



10 Press the **Cal Step** softkey.

- Display softkey annunciators show:



* Only displayed if Option 106 or Option 115 is installed.

11 Press the **Oscil** softkey.

- Display softkey annunciators show:

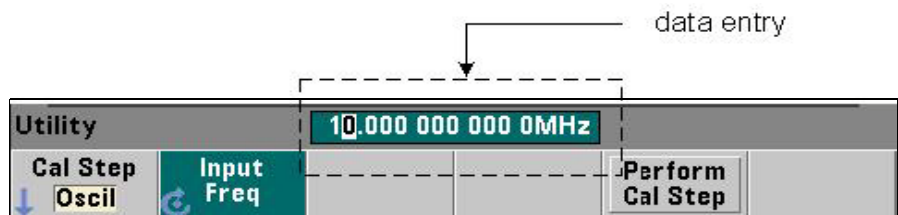

NOTE

The data entry area will display the expected calibration frequency (10.000 MHz).

- 12** Press the **Perform Cal Step** softkey to enter the data into the counter and initiate the reference oscillator calibration.
- If the calibration step PASSES, after a few seconds the counter momentarily displays:
 - “Calibration step succeeded.”
 - The **Cal Count** on the screen increments.
 - If the calibration step FAILS, after a few seconds the counter displays:
 - **“Calibration step failed”**
 - After several seconds, **“Calibration step failed”** is cleared.
 - The **Cal Count** does not increment.

NOTE

If the calibration fails, the current calibration constants remain unchanged.

13 If the calibration fails (**“Calibration step failed”**), first verify the input frequency is correct and the source output is connected and turned on. Then, refer to the troubleshooting procedures on [page 160](#).

14 To check for error messages, refer to the “Remote Oscillator Calibration Summary” below for information on how to read the error message(s) from a remote computer.

NOTE

If you do not have a remote computer available (requires a LAN, USB or GPIB interface) or are not proficient at programming, contact the nearest Keysight Service Center for information and help on sending the counter to Keysight for repair and/or calibration.

NOTE

If you are able to read the error message(s), consult **“Error Messages”** on [page 174](#) for what to do after receiving a specific calibration error message.

Summary of oscillator calibration procedure:

- Input signal: This should be a clean square wave with a fast rise time at 10 MHz, 1 Vp-p, 0V DC offset
- Timebase: Any external timebase you provide is ignored during calibration.
- Verify signal input connections and that source output is ON.
- Procedure: From the front-panel, the following key strokes initiate the internal reference oscillator calibration:

[Utility] / (Cal AutoCal) / (Perform Cal) / (Cal Step Oscil) / enter <Input Freq> / (Perform Cal Step)

Remote oscillator calibration summary:

- Set timeout for PC to be greater than 20 seconds.
- Connect calibration source to channel 1 (10.000 000 000 MHz).
- Unlock security: **CALibration:SECurity:STAtE OFF**, <code>
- Read security state: **CALibration:SECurity:STAtE?**
 - 0 means OFF or unlocked.
- Send command to calibrate: "**CALibration:VALue 10E6**".
- Send query command: "**CAL?**".
- Retrieve query result:
 - 0 indicates the calibration PASSED.
 - Any value other than 0 indicates calibration FAILED.
- If non-zero value, read error queue: **SYSTem:ERRor?** Read errors until no more errors. Consult the Error Messages section starting on [page 174](#) for more information on specific calibration error messages.

NOTE

For remote calibration, an Internal Reference Oscillator calibration is automatically selected (over internal DAC calibration) since the cal value of 10E6 is larger than the acceptable DAC voltage range.

NOTE

An AutoCal is performed automatically after this calibration is successfully completed.

Voltage calibration (internal DACs)

NOTE

The Calibration menu is accessed by pressing the **Utility** key and then the **Cal/ AutoCal** softkey.

- 1 First, run the counter Self-Test as described under “**Performing the counter self-test**” on page 169. A successful self-test procedure verifies that the counter is operational and ready for calibration.
- 2 Unlock the counter by performing the procedure “**To unlock the counter for calibration:**” on page 116. Key sequence:
[Utility] / (Cal AutoCal) / enter <code> / (Unlock Cal)
- 3 Set up an external, low-noise +/- DC voltage source, such as the Keysight 6234A DC Power Supply, to output a voltage of +4.0 VDC. Do not connect the output to the counter input connector until instructed to do so.

NOTE

The preferred voltage for optimum calibration accuracy is +4.096 Volts DC. However, if your power supply can not be set to that specific value, set it as close to +4.0 VDC as possible (acceptable range is 3-5 V). The entered value for calibration **MUST** be within 1.0 milliVolt of the actual voltage source output. It is suggested that a BNC ‘T’ be connected to the power supply output to enable a DMM to measure the voltage that will be applied to the counter.

- 4 Press the **Utility** key and then the **Cal/AutoCal** softkey:

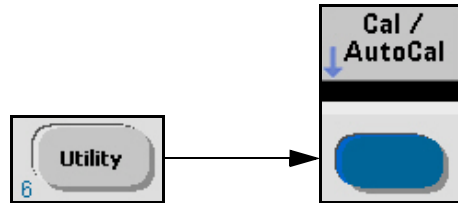

- The Calibration menu option softkeys are displayed:



- The display shows:



- **Cal Count** shows the total number of times: (1) a successful calibration step has been completed; (2) calibration data is downloaded; (3) the Cal String or Secure Code is updated; (4) the counter firmware is updated. It is not operator-modifiable and rolls over at $(2^{32} - 1)$. Since the unit is calibrated several times during manufacture, the Cal Count will not be zero when shipped.

- **Cal String** shows the current calibration string. This string is operator-modifiable, used to record such information as the date of the last calibration, or by whom it was performed. The Calibration String can not be entered from the front panel keys. It can only be entered/updated using the remote SCPI command: **CALibration STRing**. Refer to the Keysight 53210A/53220A/53230A SCPI Programmer's Reference for details of the command format.
- **Secure Code** displays either all dashes (---) or an operator-entered security code that has not yet been accepted by the counter.

NOTE

If **“Unlock Cal”** is displayed for a softkey, the firmware is locked against calibration. (See step 2.)

5 When **“Lock Cal”** is displayed for a softkey, the firmware is unlocked and ready for calibration. The **Perform Cal** softkey then becomes available.

6 Press the **Perform Cal** softkey.

- Display softkey annunciators show:



7 Press the **Cal Step** softkey.

- Display softkey annunciators show:



* Only displayed if Option 106 or 115 is installed.

- 8 Press the **Pos Volt** softkey. Softkeys change to:



- Data entry display area reads **4.096 V (default)** and is modifiable.
- 9 The value shown in the data entry area must equal the power supply output voltage as measured by the DMM (+4.096 or +4.000). Use the front panel knob and left/right arrow keys to enter the value ($\pm 1\text{mV}$).
- 10 Connect the DC voltage source to Channel 1 on the counter front panel as shown in [Figure 2-6](#).

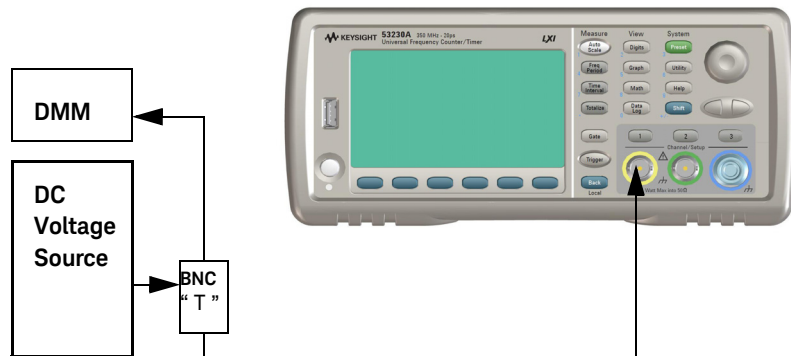

Figure 2-6 DC voltage source and DMM connections

- 11 Press the **Perform Cal Step** softkey.
- If the calibration step **PASSES**, after a few seconds the counter momentarily displays:
 - **“Calibration step succeeded.”**
 - The **Cal Count** on the screen will increment.

- If the calibration step FAILS, after a few seconds the counter displays:
 - **“Computed calibration correction factor out of range”** and also **“Calibration step failed”**.
 - After several seconds, **“Calibration step failed”** is cleared but **“Computed calibration correction factor out of range”** remains.
 - The **Cal Count** does not update.
- Press the **Back - Local** key to clear the **“Computed calibration correction factor out of range”** message.

NOTE

If the calibration fails, the current calibration constants remain unchanged.

- 12** If the correction factor is out of range, the entered voltage value does not agree with the power supply output ± 1.0 mVolt. Correct the mismatch and try again.
- 13** If the Positive Voltage calibration passes, repeat steps 3 through 13 using -4.096 VDC and **Negative Voltage** for the **Cal Step** selection.
- 14** If the calibration fails (**“Calibration step failed”**), first verify the input voltage is correct (within 1.0 millivolt) and the power supply output is connected and turned on. Then, refer to the troubleshooting procedures starting on [page 160](#).
- 15** To check for error messages, refer to the [Summary of internal DAC remote calibration](#): below for information on how to read the error message(s) from a remote computer.

NOTE

If you do not have a remote computer available (requires a LAN, USB or GPIB interface) or are not proficient at programming, contact the nearest Keysight Service Center for information and help on sending the counter to Keysight for repair and/or calibration. (See website information on page 2 of this guide.)

- 16** If you are able to read the error message(s), consult the [“Error Messages”](#) on page 174 for what to do after receiving a specific calibration error message.

Summary of internal DAC calibration procedure:

- Input voltage: should have minimal peak-to-peak noise
- Procedure: From the front-panel, the following key strokes initiate the internal DAC calibration:
[Utility] / (Cal AutoCal) / (Perform Cal) / (Cal Step Pos Volt) or (Neg Volt) / enter <voltage> / (Perform Cal Step)

Summary of internal DAC remote calibration:

- Set timeout for PC to be greater than 20 seconds.
- Connect calibration voltage source to channel 1 (4.096 Volts DC).
- Unlock security: **CALibration:SECurity:STATe OFF, <code>**
- Read security state: **CALibration:SECurity:STATe?**
0 means OFF or unlocked.
- Send the calibrate command: **CALibration:VALue 4.096** (repeat with **CAL:VAL-4.096**).
- Send query command: **CAL?**.
- Retrieve query result:
0 indicates the calibration PASSED.
Any value other than 0 indicates calibration FAILED.
- If non-zero value, read error queue: **SYSTem:ERRor?**
- Read errors until no more errors.
- Consult the “Error Messages” section starting on [page 174](#) for what to do after receiving a specific calibration error message.

NOTE

For a remote internal DAC calibration, DAC Cal is automatically selected (over internal reference oscillator calibration) since the cal value of 4.096 is smaller than the acceptable reference oscillator frequency range.

NOTE

An AutoCal is performed automatically after this calibration is successfully completed.

Option 106 microwave channel frequency calibration

The following procedure should be performed when Option 106 (6 GHz Microwave channel) with any Option 106 firmware revision other than FW Rev 27 is installed as Channel 2 in a 53210A or Channel 3 in a 53220A or 53230A. See [Chapter 6, "Backdating"](#) for the procedure to calibrate Option 106 with FW Rev 27. (Refer to ["Determine the counter firmware version"](#) on page 119.)

- 1 First, run the counter Self-Test as described under ["Performing the counter self-test"](#) on page 169. A successful self-test procedure verifies that the counter is operational and ready for calibration.
- 2 Unlock the counter by performing the procedure ["To unlock the counter for calibration."](#) on page 116. Key sequence:

[Utility] / (Cal AutoCal) / enter <code> / (Unlock Cal)

- 3 Set up an external microwave frequency source for a 500 MHz sine wave at -27 dBm. If the source has an 'output enable' feature, turn it OFF at first (for the zero-calibration procedure).
- 4 Connect the microwave frequency source to Channel 3 on the counter front panel. (Channel 2 for a 53210A.) See [Figure 2-7](#).

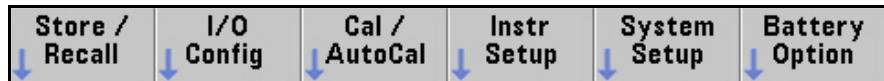

Figure 2-7 Microwave source connection to Channel 3

- 5 Press the **Utility** key:



- Display softkey annunciators show:



- 6 Press the **Cal/AutoCal** softkey to display the calibrate options.

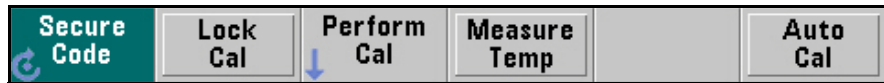

- Display shows:



- **Cal Count** shows the total number of times: (1) a successful calibration step has been completed; (2) calibration data is downloaded; (3) the Cal String or Secure Code is updated; (4) the counter firmware is updated. It is not operator-modifiable and rolls over at $(2^{32} - 1)$. Since the unit is calibrated several times during manufacture, the Cal Count will not be zero when shipped.

- **Cal String** shows the current calibration string. This string is operator-modifiable, used to record such information as the date of the last calibration, or by whom it was performed. The Calibration String can not be entered from the front panel keys. It can only be entered/updated using the remote SCPI command: **CALibration STRing**. Refer to the Keysight 53210A/53220A/53230A SCPI Programmer’s Reference for details of the command format.
 - **Secure Code** displays either all dashes (---) or an operator-entered security code that has not yet been accepted by the counter.
- 7** If **“Unlock Cal”** is displayed on a softkey, the counter is locked against calibration. (See step 2.)
- 8** If **“Lock Cal”** is displayed on a softkey, the counter is unlocked and ready for calibration.
- The **Perform Cal** softkey becomes available.
- 9** Press the **Perform Cal** softkey:
- Display softkey annunciators show:



- 10** Press the **Cal Step** softkey.
- Display softkey annunciators show:



* Only displayed if Option 106 or 115 is installed.

- 11** Press the **uWave** softkey.
- Display softkey annunciators show:



NOTE

If your microwave source does not have an 'output enable/disable' feature, temporarily disconnect the cable from the microwave input channel until after the zero-calibration is performed.

12 Press the **Perform Zero-Cal** softkey to perform zero-calibration.

- Display momentarily shows:



- After a few seconds, display momentarily shows:



13 Select the 'output enable' ON feature of the microwave source or reconnect the cable to the counter, as appropriate.

14 Use the front panel knob and left/right arrow keys to enter the value (500 MHz) as shown.



- 15 Press the **Input Power** softkey and enter the power level of the 500 MHz source as -27 dBm (actual input power at the counter must be $-27 \text{ dBm} \pm 0.5 \text{ dB}$).

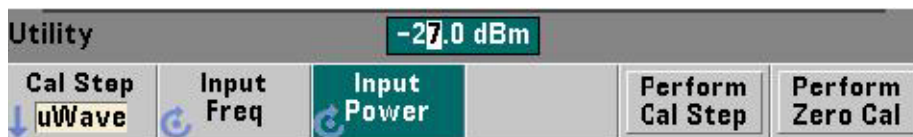

- 16 Press the **Perform Cal Step** softkey to enter the data into the counter and initiate the microwave oscillator calibration.
- If the calibration step PASSES, after a few seconds the counter momentarily displays "Calibration step succeeded."
 - The internal calibration constants are updated.
 - The **Cal Count** on the screen will increment.
- 17 Repeat steps 14 to 16 using each of the calibration frequencies and power levels in [Table 2-2](#) (total of 36 steps). For each calibration step, set the source frequency and power accordingly.

Table 2-2 Option 106 calibration frequencies and power levels

Test point	Frequency (MHz)	Power level 1	Power level 2	Power level 3
1	500 MHz	-27 dBm	-4 dBm	+10 dBm
2	1500 MHz	-27 dBm	-4 dBm	+10 dBm
3	2500 MHz	-27 dBm	-4 dBm	+10 dBm
4	3000 MHz	-27 dBm	-4 dBm	+10 dBm
5	3500 MHz	-27 dBm	-4 dBm	+10 dBm
6	4000 MHz	-27 dBm	-4 dBm	+10 dBm
7	4500 MHz	-27 dBm	-4 dBm	+10 dBm
8	5000 MHz	-27 dBm	-4 dBm	+10 dBm
9	5250 MHz	-27 dBm	-4 dBm	+10 dBm
10	5500 MHz	-27 dBm	-4 dBm	+10 dBm

Table 2-2 Option 106 calibration frequencies and power levels (continued)

Test point	Frequency (MHz)	Power level 1	Power level 2	Power level 3
11	5750 MHz	-27 dBm	-4 dBm	+10 dBm
12	6000 MHz	-27 dBm	-4 dBm	+10 dBm

18 If any calibration step FAILS, after several seconds the counter displays **“Calibration step failed”** .

19 If the calibration fails (**“Calibration step failed”**), first verify the input frequency and power are correct and the source output is connected and turned on. Then, refer to **“Troubleshooting the Counter”** on page 160.

NOTE

If the calibration fails for any calibration point (including zero-cal), the current calibration constants for that frequency and power level, and the **Cal Count**, remain unchanged.

20 To check for error messages, refer to the **Summary of Option 106 remote microwave calibration**: below for information on how to read the error message(s) from a remote computer.

NOTE

If you do not have a remote computer available (requires a LAN, USB or GPIB interface) or are not proficient at programming, contact the nearest Keysight Service Center for information and help on sending the counter to Keysight for repair and/or calibration.

21 If you are able to read the error message(s), consult **“Error Messages”** on page 174 for what to do after receiving a specific calibration error message.

Summary of Option 106 microwave calibration procedure:

- Input signal: This should be a clean sine wave at each frequency and power level, driving 50 Ω termination.
- Timebase: Any external timebase you provide is ignored during calibration.
- Verify signal input connections and source output is ON.
- Procedure: From the front-panel, the following key strokes initiate the microwave frequency channel calibration:

[Utility] / (Cal AutoCal) / (Perform Cal) / (Cal Step uWave) / enter (Input Freq) <frequency>

[Utility] / (Cal AutoCal) / (Perform Cal) / (Cal Step uWave) / enter (Input Power) <power> / (Perform Cal Step)

Summary of Option 106 remote microwave calibration:

- Set timeout for PC to be greater than 20 seconds.
- Unlock security: **CALibration:SECurity:STATe OFF, <code>**
- Read security state: **CALibration:SECurity:STATe?**
 - 0 means OFF or unlocked.
- Send zero-calibration command (one-time only):
 - Use: **"CALibration:LEVe13? 0,0"** for 53220A/53230A.
 - Use: **"CALibration:LEVe12? 0,0"** for 53210A.
- Retrieve query result:
 - 0 indicates the calibration PASSED.
 - Any value other than 0 indicates calibration FAILED.
- Connect calibration source to channel 2 (53210A) or channel 3 (at 500 MHz, -27 dBm for Option 106).
- Send command to calibrate: **"CALibration:LEVe13? 500E6, -27"**.
 - Use **"CALibration:LEVe12? 500E6, -27"** for 53210A.
- Retrieve query result:
 - 0 indicates the calibration PASSED.
 - Any value other than 0 indicates calibration FAILED.

- If non-zero value, read error que: **SYSTEM:ERROR?**
- Read errors until no more errors.
- Repeat as necessary for all values in [Table 2-2](#).
- Consult the “Error Messages” starting on [page 174](#) for what to do after receiving a specific calibration error message.

This concludes the Option 106 calibration procedure.

Option 115 microwave channel frequency calibration

The following procedure should be performed when Option 115 (15 GHz Microwave channel) with any Option 115 firmware revision is installed as Channel 2 in a 53210A or Channel 3 in a 53220A or 53230A.

- 1 Press the following keys:

[Help] / (About)

- 2 The display shows:

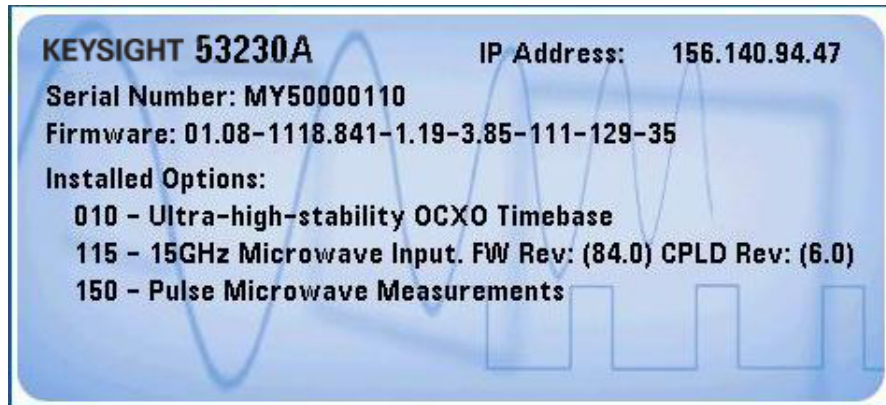

- 3 Run the counter Self-Test as described under “[Performing the counter self-test](#)” on page 169. A successful self-test procedure verifies that the counter is operational and ready for calibration.

- 4 Unlock the counter by performing the procedure “To unlock the counter for calibration:” on page 116. Key sequence:
[Utility] / (Cal AutoCal) / enter <code> / (Unlock Cal)
- 5 Set up an external microwave frequency source for a 300 MHz sine wave at -21 dBm. If the source has an ‘output enable’ feature, turn it OFF at first (for the zero-calibration procedure).
- 6 Connect the microwave frequency source to Channel 3 on the counter front panel. (Channel 2 for a 53210A.) See **Figure 2-8**.

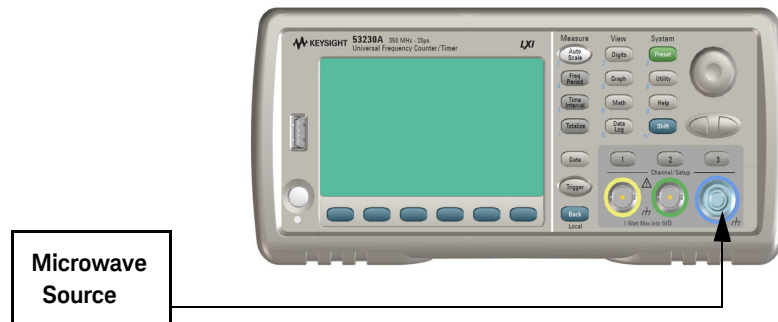

Figure 2-8 Microwave source connection to Channel 3

- 7 Press the **Utility** key:



- Display softkey annunciators show:



- 8 Press the **Cal/AutoCal** softkey to display the calibrate options.

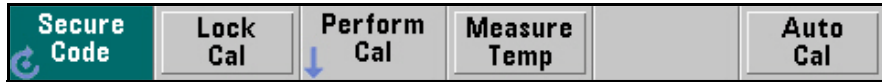

- Display shows:



- **Cal Count** shows the total number of times: (1) a successful calibration step has been completed; (2) calibration data is downloaded; (3) the Cal String or Secure Code is updated; (4) the counter firmware is updated. It is not operator-modifiable and rolls over at $(2^{32} - 1)$. Since the unit is calibrated several times during manufacture, the Cal Count will not be zero when shipped.
 - **Cal String** shows the current calibration string. This string is operator-modifiable, used to record such information as the date of the last calibration, or by whom it was performed. The Calibration String can not be entered from the front panel keys. It can only be entered/updated using the remote SCPI command: **CALibration STRing**. Refer to the Keysight 53210A/53220A/53230A SCPI Programmer's Reference for details of the command format.
 - **Secure Code** displays either all dashes (---) or an operator-entered security code that has not yet been accepted by the counter.
- 9 If **"Unlock Cal"** is displayed on a softkey, the counter is locked against calibration. (See step 2.)

10 If **“Lock Cal”** is displayed on a softkey, the counter is unlocked and ready for calibration.

- The **Perform Cal** softkey becomes available.

11 Press the Perform Cal softkey:

- Display softkey annunciators show:



12 Press the **Cal Step** softkey.

- Display softkey annunciators show:



* Only displayed if Option 106 or 115 is installed.

13 Press the **uWave** softkey.

- Display softkey annunciators show:



NOTE

If your microwave source does not have an ‘output enable/disable’ feature, temporarily disconnect the cable from the microwave input channel until after the zero-calibration is performed.

14 Press the **Perform Zero-Cal** softkey to perform zero-calibration.

- Display momentarily shows:

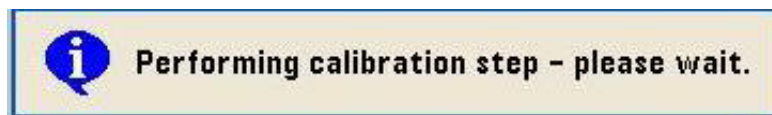

- After a few seconds, display momentarily shows:



- 15 Select the 'output enable' ON feature of the microwave source or reconnect the cable to the counter, as appropriate.
- 16 Use the front panel knob and left/right arrow keys to enter the value (300 MHz) as shown.



- 17 Press the **Input Power** softkey and enter the power level of the 300 MHz source as -21 dBm. (Actual input power at the counter must be -21 dBm ± 0.5 dB. If necessary, verify with a power meter.)



- 18 Press the **Perform Cal Step** softkey to enter the data into the counter and initiate the microwave oscillator calibration.
 - If the calibration step PASSES, after a few seconds the counter momentarily displays "Calibration step succeeded."
 - The internal calibration constants are updated.
 - The **Cal Count** on the screen will increment.
- 19 Repeat steps 16 to 18 using each of the calibration frequencies and power levels in [Table 2-3](#) (total of 36 steps). For each calibration step, set the source frequency and power accordingly.

Table 2-3 Option 115 calibration frequencies and power levels

Test point	Frequency (MHz)	Power level 1	Power level 2	Power level 3
1	300 MHz	-21 dBm	-4 dBm	+10 dBm
2	1000 MHz	-21 dBm	-4 dBm	+10 dBm
3	3000 MHz	-21 dBm	-4 dBm	+10 dBm
4	5000 MHz	-21 dBm	-4 dBm	+10 dBm
5	7000 MHz	-21 dBm	-4 dBm	+10 dBm
6	9000 MHz	-21 dBm	-4 dBm	+10 dBm
7	10000 MHz	-21 dBm	-4 dBm	+10 dBm
8	11000 MHz	-21 dBm	-4 dBm	+10 dBm
9	12000 MHz	-21 dBm	-4 dBm	+10 dBm
10	13000 MHz	-21 dBm	-4 dBm	+10 dBm
11	14000 MHz	-21 dBm	-4 dBm	+10 dBm
12	15000 MHz	-21 dBm	-4 dBm	+10 dBm

- 20** If any calibration step FAILS, after several seconds the counter displays **“Calibration step failed”**.
- 21** If the calibration fails (**“Calibration step failed”**), first verify the input frequency and power are correct and the source output is connected and turned on. Then, refer to **“Troubleshooting the Counter”** on page 160.

NOTE

If the calibration fails for any calibration point (including zero-cal), the current calibration constants for that frequency and power level, and the **Cal Count**, remain unchanged.

- 22** To check for error messages, refer to the **Summary of Option 115 remote microwave calibration**: below for information on how to read the error message(s) from a remote computer.

NOTE

If you do not have a remote computer available (requires a LAN, USB or GPIB interface) or are not proficient at programming, contact the nearest Keysight Service Center for information and help on sending the counter to Keysight for repair and/or calibration.

23 If you are able to read the error message(s), consult “[Error Messages](#)” on page 174 for what to do after receiving a specific calibration error message.

Summary of Option 115 microwave calibration procedure:

- Input signal: This should be a clean sine wave at each frequency and power level, driving 50 Ω termination.
- Timebase: Any external timebase you provide is ignored during calibration.
- Verify signal input connections and source output is ON.
- Procedure: From the front-panel, the following key strokes initiate the microwave frequency channel calibration:

[Utility] / (Cal AutoCal) / (Perform Cal) / (Cal Step uWave) / enter (Input Freq) <frequency>

[Utility] / (Cal AutoCal) / (Perform Cal) / (Cal Step uWave) / enter (Input Power) <power> / (Perform Cal Step)

Summary of Option 115 remote microwave calibration:

- Set timeout for PC to be greater than 20 seconds.
- Unlock security: **CALibration:SECurity:STATE OFF, <code>**
- Read security state: **CALibration:SECurity:STATE?**
 - 0 means OFF or unlocked.
- Send zero-calibration command (one-time only):
 - Use: “**CALibration:LEVe13? 0,0**” for 53220A/53230A.
 - Use: “**CALibration:LEVe12? 0,0**” for 53210A.
- Retrieve query result:
 - 0 indicates the calibration PASSED.
 - Any value other than 0 indicates calibration FAILED.

- Connect calibration source to channel 2 (53210A) or channel 3 (53220A or 53230A) at 300 MHz, -21 dBm for Option 115.
- Send command to calibrate: “**CALibration:LEVe13? 300E6, -21**”.
- Use “**CALibration:LEVe12? 300E6, -21**” for 53210A.
- Retrieve query result:
 - 0 indicates the calibration PASSED.
 - Any value other than 0 indicates calibration FAILED.
- If non-zero value, read error que: **SYSTem:ERRor?**
- Read errors until no more errors.
- Repeat as necessary for all values in [Table 2-3](#).
- Consult the “Error Messages” starting on [page 174](#) for what to do after receiving a specific calibration error message.

This concludes the Option 115 calibration procedure.

Internal auto-calibration

No external inputs are required for running auto-calibration. Auto-calibration runs a select series of internal calibration routines using internal standards and stores appropriate calibration constants for use in subsequent measurements. This operation fine-tunes the current calibration based on the internal temperature of the counter. If the auto-calibration completes normally, the existing constants are replaced by the new values obtained. If any one of the internal routines fails, all existing constants remain the same.

It is not necessary to unsecure the counter for auto-calibration. Auto-Cal does not increase the Cal Count. Auto-Cal is also a subset of Self-Test, so every time you perform a counter Self-Test you also perform an Auto-Cal.

It is not necessary to disconnect signal input cabling when performing auto-calibration, but all input signals should be turned OFF.

NOTE

It is recommended that Auto-Cal be performed frequently during routine counter operation, especially if there has been an internal ambient temperature change of 5° C or more since the last Auto-Cal. A good practice is to perform Auto-Cal at the beginning of a new day of use, at an operator shift change, or other strategic time. However, it may not be desirable to perform an Auto-Cal in the middle of a series of measurements, since the cal constants are updated each time Auto-Cal is performed.

The current internal ambient temperature and the temperature at the last Auto-Cal can be seen simultaneously using:

[Utility] / (Cal AutoCal) / (Measure Temp)

To run auto calibration:

- 1 Press the **Utility** key and then the **Cal / AutoCal** softkey to display the calibrate options.

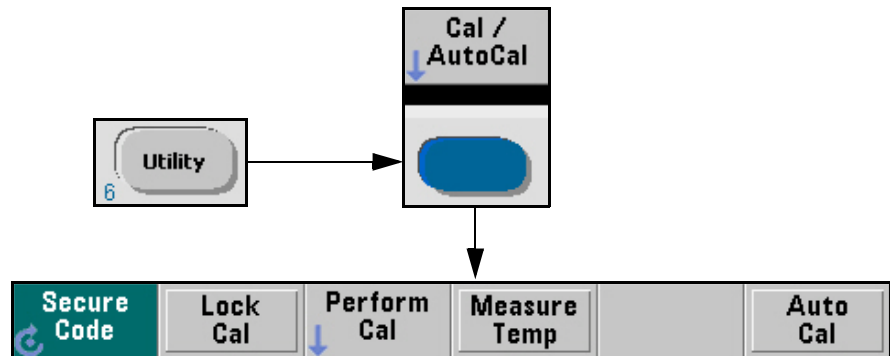

- 2 Press **Auto Cal**.
 - Display stops updating until auto-calibration is completed (several seconds).
 - If the calibration is successful, the screen displays “**Auto Calibration succeeded**”.
 - **Cal Count** is not updated, but the calibration constants ARE updated.
 - If any one of the calibration routines fails, the screen displays “**Auto Calibration failed**”.

NOTE

When the auto-calibration completes, a pass/fail message will be displayed. If the calibration failed, then the current calibration constants remain unchanged.

- 3 If the auto-calibration fails (“**Auto-calibration failed**”), first verify any inputs connected to the counter are turned OFF. Then, refer to the troubleshooting procedures starting on [page 160](#).
- 4 To check for error messages, refer to the [Summary of remote auto-calibration](#): below for information on how to read the error message(s) from a remote computer.

NOTE

If you do not have a remote computer available (requires a LAN, USB or GPIB interface) or are not proficient at programming, contact the nearest Keysight Service Center for information and help on sending the counter to Keysight for repair and/or calibration.

- 5 If you are able to read the error message(s), consult “[Error Messages](#)” on page 174 for what to do after receiving a specific calibration error message.

Summary of auto-calibration procedure:

- Procedure: From the front-panel, the following key strokes initiate the auto-calibration:
 - **[Utility] / (Cal AutoCal) / (Auto Cal)**

Summary of remote auto-calibration:

- Send command ***CAL?**. (Note use of the “*”)
- Wait 10 seconds.
- Retrieve query result:
 - 0 indicates the auto-calibration PASSED.
 - Any value other than 0 indicates auto-calibration FAILED.
- If the retrieved value is non-zero, read error queue: **SYSTem:ERRor?**
 - Read errors until no more errors.

- Consult the “Error Messages” section on [page 174](#) for what to do after receiving a specific calibration error message.

To view the calibration count

- 1 Press the **Utility** key and then press the **Cal/AutoCal** softkey.

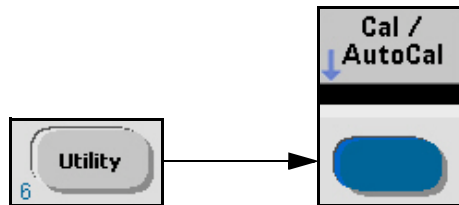

- 2 The display shows:



- **Cal Count** shows the total number of times: (1) a successful calibration step has been completed; (2) calibration data is downloaded; (3) the Cal String or Secure Code is updated; (4) the counter firmware is updated. It is not operator-modifiable and rolls over at $(2^{32} - 1)$. Since the unit is calibrated several times during manufacture, the Cal Count will not be zero when shipped.

- **Cal String** shows the current calibration string. This string is operator-modifiable, used to record such information as the date of the last calibration, or by whom it was performed. The Calibration String can not be entered from the front panel keys. It can only be entered/updated using the remote SCPI command: **CALibration STRing**. Refer to the Keysight 53210A/53220A/53230A SCPI Programmer's Reference for details of the command format.
- **Secure Code** displays either all dashes (---) or an operator-entered security code that has not yet been accepted by the counter.

Resetting the security code to a null

In case a CAL security override is required at any time:

- Create a text file with the defined name "**CalSecureOverride.txt**" in an external USB flash drive at the root directory. This file should be empty.
- Connect the USB drive to the counter front panel USB port.

NOTE

Where USB usage is not allowed, FTP can be used to input the file into the instrument.

- Power the instrument off and back on.
 - At startup, the counter will detect the "CalSecureOverride.txt" empty file on the USB flash drive and there will be a message on the front panel display: "**CAL Security Override file found. Turn OFF CAL security?**" which must be responded to within 10 seconds time.
 - If the operator responds to the message (by pressing the **YES** soft key), the counter will turn OFF the **CALibration SECurity STATe**.
 - A front panel message "**CAL Secure State is turned Off**" will be displayed.
 - As the Calibration secure state is now OFF (i.e. the counter has been un-secured) the operator can enter a new Secure Code.
 - At this point, the operator can either turn the Calibration secure state back ON or leave the box unsecured, as desired.
 - The "**CalSecureOverride.txt**" file is automatically erased from the USB flash drive, regardless of the user action or non-action.

Pre-Troubleshooting Information

This section contains the following pertinent troubleshooting information:

- Safety Considerations
- Recommended Test Equipment
- Repair Considerations
- After Service Considerations
- Assembly Identification and Location

Safety considerations

Although this instrument has been designed in accordance with international safety standards, this guide contains information, cautions, and warnings which must be followed to ensure safe operation and to maintain the instrument in a safe condition. Service instructions, and adjustment procedures requiring removal of the instrument cover, are for use by service-trained personnel only. To avoid dangerous electric shock, do not perform any servicing or make any adjustments with the cover removed, unless qualified to do so.

WARNING

Before applying AC power, the instrument and all protective earth terminals, extension cords, auto transformers, and devices connected to the instrument should be connected to a protective earth grounded socket.

Any interruption of the protective grounding conductor inside or outside the instrument or disconnection of the protective earth terminal will cause a potential shock hazard that could result in personal injury. Intentional interruption is prohibited.

WARNING

Any maintenance and repair of the opened instrument under voltage should be avoided as much as possible and, if necessary, should be carried out only by a skilled person who is aware of the hazards involved (for example, fire and electric shock).

Recommended test equipment

NOTE

Test equipment recommended for testing and troubleshooting the Keysight 53210A/53220A/53230A Counters is listed below.

Table 2-4 Recommended equipment for test and troubleshooting

Instrument	Required characteristics	Recommended model
Microwave signal generator	100 MHz to 15 GHz	Keysight E8257D-520-UNW
RF signal generator	10 MHz \pm 2.000E-12	Stanford Research Systems CG635 or equivalent
Primary frequency standard (10 MHz house standard)	Absolute accuracy $>1 \times 10^{-10}$	Stanford Research Systems FS725 Rubidium Timebase
DC power supply	Adjustable to $\pm 5.000V$	Keysight 6234A or equivalent
Digital multimeter (DMM)	Microvolt accuracy	Keysight 34410A or equivalent
Type N-to-BNC connector		Keysight 1250-0780
BNC-to-dual banana plug	BNC(f) to dual banana plug(m)	Keysight E9637A
50 Ohm Coaxial cable with BNC connectors	BNC(m) to BNC(m), 48 inches	Keysight 10503A
3.5mm cables	DC-18 GHz	Keysight 11500E
Coaxial BNC tee connector		Keysight 1250-0781

NOTE

Substitute equipment may be used if it meets or exceeds the required characteristics listed in [Table 2-4](#).

Repair considerations

Electrostatic discharge

Electronic components and assemblies in the Keysight 53210A, 53220A, or 53230A Counters can be permanently degraded or damaged by electrostatic discharge. Observe the following precautions when servicing the instrument:

- 1** ENSURE that static-sensitive devices or assemblies are serviced at static-safe work stations providing proper grounding for service personnel.
- 2** ENSURE that static-sensitive devices or assemblies are stored in static shielding bags or containers.
- 3** DO NOT wear clothing subject to static-charge buildup, such as wool or synthetic materials.
- 4** DO NOT remove an assembly or component from its static shielding protection until you are ready to install it.
- 5** DO NOT handle components or assemblies in carpeted areas.
- 6** AVOID touching component leads. (Handle by packaging only.)

Surface mount repair

Surface mount components should only be removed using soldering irons or desoldering stations *expressly designed* for surface mount components. Use of conventional solder removal equipment will almost always result in permanent damage to the printed circuit board and will void your Keysight Technologies factory warranty. This paragraph is for information only. The Keysight 53210A/53220A/53230A Counters are not intended for customer repair of the printed circuit boards in these instruments.

Disassembly and reassembly specifics

Refer to [Chapter 3, "Replacing Assemblies"](#) in this guide for complete disassembly and reassembly details, and [Chapter 5, "Replaceable Parts"](#) for the appropriate part number of a failed instrument part.

After service considerations

Product safety checks

The following safety checks should be performed after any troubleshooting and repair procedures have been completed to ensure the safe operation of the instrument.

WARNING

Resistance checks described in the following text require that the power cord be connected to the instrument and that AC power be disconnected. Be sure that the power cord is not connected to power before performing any safety checks.

- 1 VISUAL INSPECTION. Visually inspect the interior of the instrument for any signs of abnormal internally generated heat, such as discolored printed circuit boards or components, damaged insulation, or evidence of arcing. Determine and remedy the cause of any such condition.
- 2 GROUND CONTINUITY TEST. Plug the power cord into the rear-panel power receptacle. (DO NOT connect the instrument to AC power at this time.) Using a suitable ohmmeter or digital multimeter (DMM), check the resistance from the instrument's metallic connection (such as the rear panel or BNC ground collar) to the ground pin on the power cord plug. The reading must be less than 1Ω . Flex the power cord while making this measurement to determine whether intermittent discontinuities exist.
- 3 Check any indicated front- or rear-panel ground terminals marked, using the above procedure.

NOTE

INSULATION RESISTANCE TEST. Tie the line and neutral pins of the power cord plug together. Measure the resistance from the instrument enclosure (chassis) to the line and neutral pins of the power cord. The minimum acceptable resistance is $2\text{ M}\Omega$. Replace any component which results in a failure.

NOTE

Table 2-5, Figure 2-9 and Figure 2-10 show the replaceable assemblies in the Keysight 53210A/53220A/53230A. Refer also to Chapter 5, "Replaceable Parts" for other part numbers.

Table 2-5 Keysight 53210A/53220A/53230A assembly identification

Assembly name #	Keysight part no.
Motherboard	
53210A	53210-66101 (standard timebase)
	53210-66102 (high stability timebase)
53220A	53220-66101 (standard timebase)
	53220-66102 (high stability timebase)
53230A	53220-66101 (standard timebase)
	53220-66102 (high stability timebase)
Front panel display board	
Display	2090-0977
Real Time Clock Battery	1420-0356 (commercial CR2032)
Fan	33250-68501
Microwave channel input board	
Option 106 (6 GHz)	Customers must order: 53200U-106 **
Option 115 (15 GHz)	53200U-115 **
AC power supply	p/o 53200-80002
DC power supply	
Option 300	p/o 53200-80003 (Battery Charger Assembly) 1420-0909 (Battery, +12 volt DC)
Processor board	*
GPIB assembly	53200U-400 **

Refer to [Chapter 6, "Backdating"](#) for other information on the assemblies inside your counter. Contact your local Keysight Technologies Service Center for current information. Refer also to [Chapter 5, "Replaceable Parts"](#) for other part numbers.

* Not customer-replaceable. Must return to Keysight Technologies for replacement. (Firmware compatibility requirements.)

** These items are not obtainable through the Keysight Parts Organization. If these parts are defective, the instrument may be sent to Keysight for repair. As an alternative, you may order replacement parts as retrofit options using the provided order number. See the preface for information on contacting Keysight.

CAUTION

DO NOT swap the motherboard, the processor board, or the front panel board from one instrument to another. These boards contain model number and serial number information that uniquely identifies a specific unit, and boards that are mismatched to the instrument may result in problems with performance, licensing, serviceability, importability/exportability or warranty.

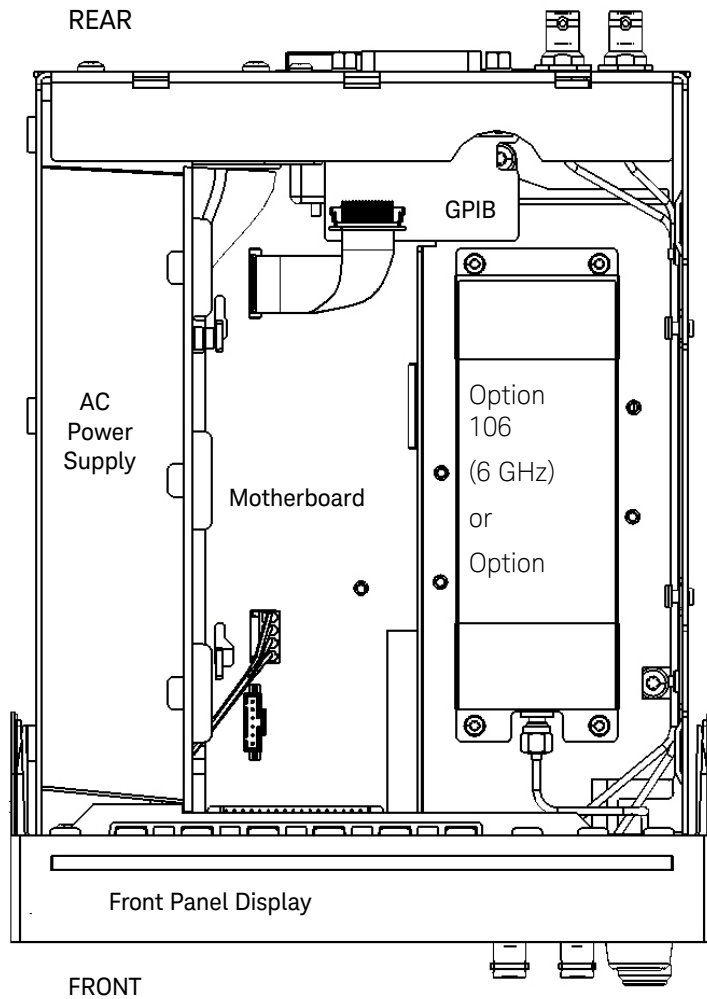

Figure 2-9 Counter top internal view

NOTE

Option 300 (Internal DC battery assembly), if installed, is on top of, and covers, the motherboard and Option 106/115 Assemblies.

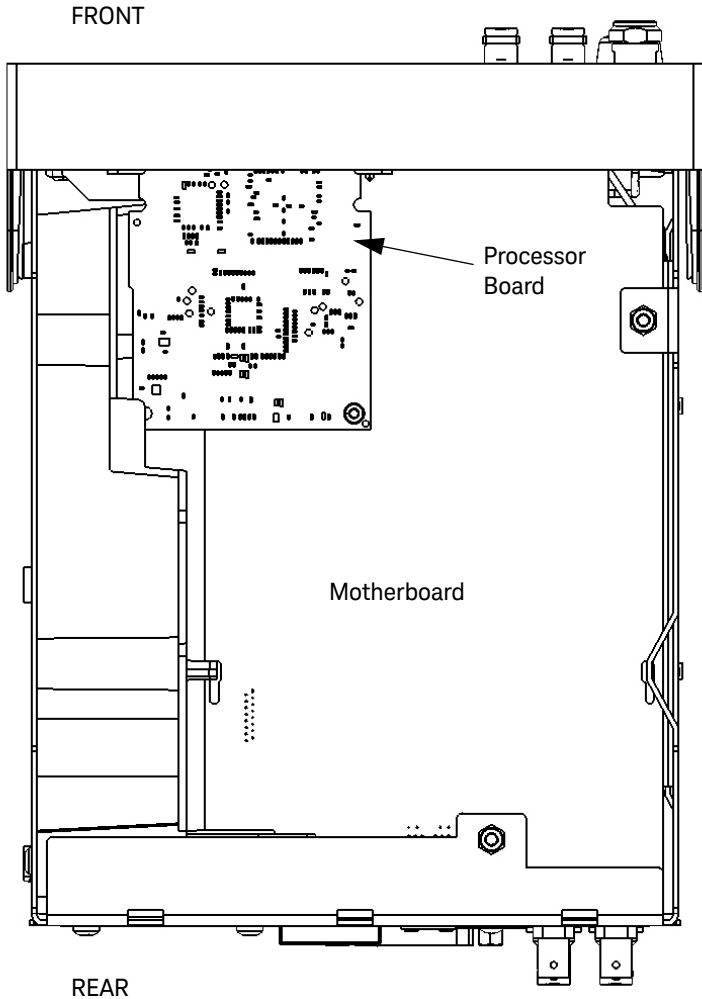

Figure 2-10 Bottom internal view

Troubleshooting the Counter

This section provides a brief check list of common failures. Before troubleshooting or repairing the instrument, make sure the failure is in the instrument rather than any external connections. Also make sure that the instrument has been accurately calibrated within the last year.

The instrument's circuits allow troubleshooting and repair to an assembly level with basic test equipment.

Unit is inoperative

- Verify that the AC power cord is connected to the instrument and to an AC power source.
- Verify that the front-panel On/Standby switch has been pressed.

Unit fails self-test

- Ensure that all terminal connections (both front panel and rear panel terminals) are removed while the self-test is performed.

Power supply check

WARNING

Hazardous voltages are on the power supply assembly. Only service trained and qualified personnel should perform the following procedure.

- 1 Remove the power cord from the back of the instrument to disconnect the counter from the power source.
- 2 Remove the cover as described in [Chapter 3, "Replacing Assemblies"](#).

NOTE

The AC power supply assembly is internally fused for safety reasons. It is assumed that if the internal fuses are blown, then damage has occurred to the power supply which will make it unreliable. Do not attempt to repair the power supply.

- 3 Reconnect the counter to the power source.
 - The fan should begin to operate as soon as power is applied. The fan is temperature-controlled and the fan speed (low-medium-high) will vary with the internal temperature of the counter. If the internal battery (Option 300) is installed and charging, the fan will be on high speed.

NOTE

If unsure whether the fan is running, look at the fan blades on the back of the counter to determine if the fan is running. On the low speed, the fan is very quiet.

- If the fan does not operate at all, check the power supply voltages as described below. If all the voltages are good, replace the fan (part number 33250-68501). If the +15V is missing, replace the AC Power Supply Assembly (part number 0950-5175). If one or more of the other voltages are bad, replace the motherboard.

NOTE

Refer to **Chapter 3, "Replacing Assemblies"** in this service guide if you need to remove or replace an assembly. If either the AC power supply assembly or the motherboard is replaced, perform the appropriate calibration procedures in this chapter.

- If the fan is operative, connect the negative lead of a voltmeter to the chassis and verify that the voltages in **Table 2-6** below match the voltages measured at the test points on the Motherboard Assembly. See **Figure 2-11** below for the test point locations, as viewed from the top of the counter.

CAUTION

BE CAREFUL to NOT short the positive lead of the voltmeter to the chassis when probing at the testpoints on the Motherboard.

NOTE

If the internal battery (Option 300) is installed, it will be necessary to remove it to access the test points. See **Chapter 3, "Replacing Assemblies"** for information on removing the battery.

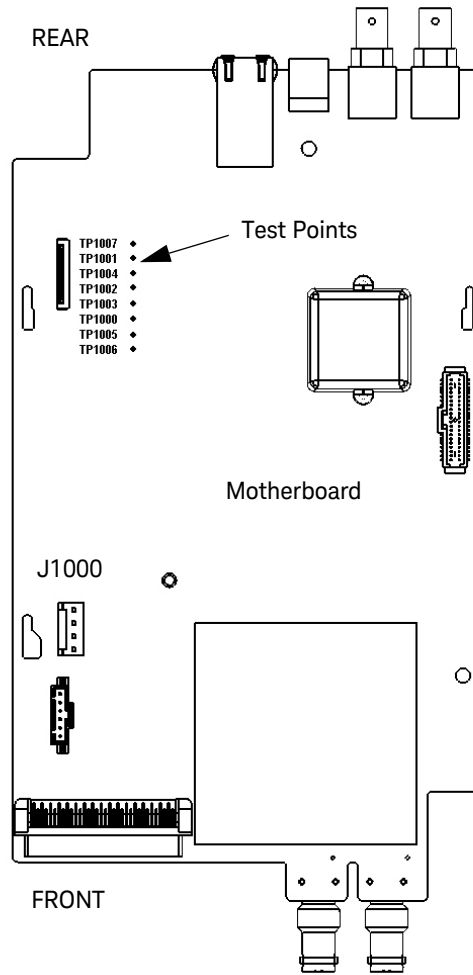

Figure 2-11 ac Power Supply Testpoint Locations on the Motherboard assembly (top view, internal battery removed, test points visible.)

Table 2-6 below lists the power supply voltages and their tolerances.

Table 2-6 DC power supply voltages

Test point	Voltage	Tolerance
T1000	+3.30 V	±0.250 V
T1001	+3.30V	±0.250 V
T1002	+5.00 V	_____
T1003	+5.00 V	_____
T1004	+2.50 V	±0.6 V
T1005	+1.20 V	_____
T1006	-5.00 V	±1.2 V
T1007	+10.0 V	-----
J1000 (pins 1,2)	+15.0 V	-----

- 4** If the +15 V is bad or missing, replace the AC Power Supply (p/n 0950-2496).
- 5** If the +3.3 V or +5 V are bad or missing, the GPIB will likely fail.
- 6** If the +15 V is present, but one or more of the other voltages are incorrect or missing, replace the motherboard.
- 7** After verifying the correct voltages, perform the counter Self-Test as described on [page 169](#).

Checking the battery and battery charger

The Option 300 Internal DC Battery is a Lithium-Ion battery that, when fully charged, provides +12 VDC voltage to the motherboard for normal operation. When fully charged, the internal DC battery can power the counter for approximately 3 hours with external AC power removed.

Battery operation

When AC power is applied to the counter, the +15 VDC from the counter's standard AC power supply is routed through the battery connector cable and back to the motherboard, where several switching power supplies are used to provide the other DC circuit voltages needed by the counter measurement circuits (see [Table 2-6](#) above).

When AC voltage is disconnected or lost from the counter, the battery (if turned ON) applies its own approximately +10 VDC to +12 VDC to the motherboard. This voltage is sufficient for the switching supplies to continue operation.

Preliminary steps

NOTE

Before proceeding, follow all the ESD steps as outlined in **“Do this first”** on page 183 of this service guide.

- 1 Remove the instrument cover as follows:

NOTE

Refer as necessary to the illustrations in the section **“To Remove the Cover and Rear Bezel”** on page 185 of this service guide.

- 2 Remove the AC power cord from the counter and disconnect any signal or interface cables present.
- 3 To remove the counter handle, rotate the handle to the vertical (90 degree) position and pull outward on the two side arms.
- 4 Using a T20 TORX screwdriver, loosen the two TORX screws securing the rear panel bezel.
- 5 Slide the outside cover of the counter to the rear and remove the cover.

- 6** Move the Option 300 Internal Battery DC Power Assembly into its service position as follows (refer to the procedure in **“To Remove the Internal DC Battery Assembly (Option 300)”** on page 187 , as needed):
- Remove the two T20 TORX screws and lock washers holding the battery assembly to the left-hand side panel (as viewed from the rear of the instrument).
 - Lift up carefully on the two side-overlapping tabs on the left side of the battery assembly and separate the assembly from the three large tabs holding it on the right side. Lay the assembly on its back to the right side of the chassis and place the three small tabs (on the back side of the three large tabs) into the three slots on the assembly deck. (See **Figure 2-12.**)

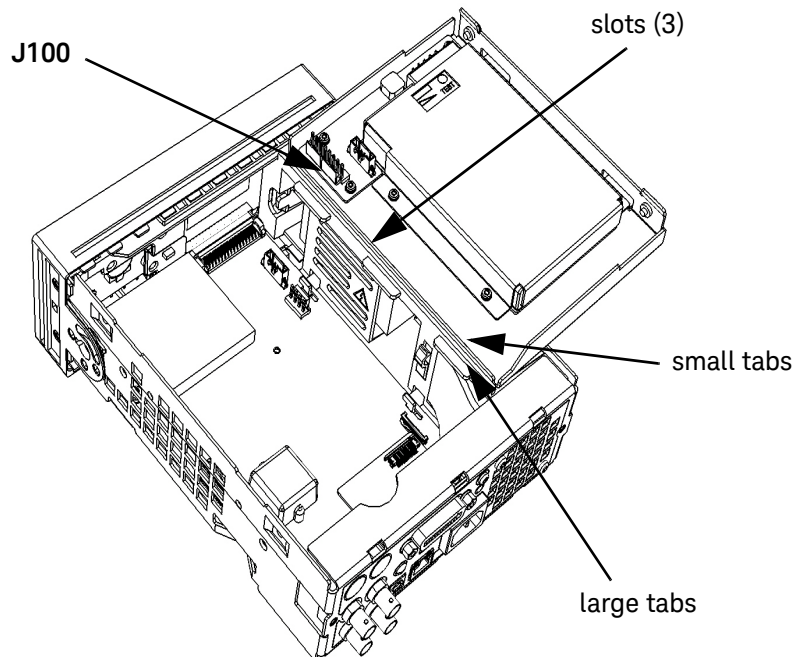

Figure 2-12 Battery folded in the service position

Testing the battery

- 7** On the Battery assembly, push and hold the white test button on the battery while observing the charge-level indicator. (See [Figure 2-13](#)). The charge level should be at least 25% to be functional. If the battery has been installed for over 24 hours with counter AC power connected the entire time, the charge level should be 75 to 100%. (Typically at least 25% after 1 hour charge.)

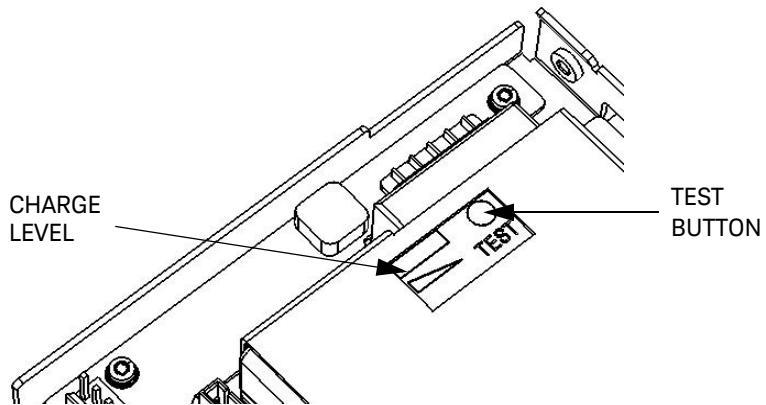

Figure 2-13 Test Button and Charge Indicator

- 8** With counter AC power still disconnected, use a DMM to measure the DC voltage on the battery charging assembly 8-pin connector (J100, still connected to the motherboard) from pins 5 & 6 to ground.
- Both pins should read between +10 and +13 VDC.
- 9** Connect the AC power cord to the counter.
- The Power LED next to the counter Power switch should be off (Standby mode).
- 10** Repeat step 8.
- Both pins 5 & 6 should read +15 VDC \pm 0.2 VDC.
 - Pins 1 & 2 should also read +15 VDC \pm 0.2 VDC. (AC Power supply output)
- 11** If the voltages in step 8 above are missing, or if there is no reading on the battery charge level indicator in step 7, replace the battery (p/n 1420-0909).

NOTE

If the battery has been totally discharged for an extended period of time, you can try charging it for 24 hours to see if it will take a charge.

- 12 If the voltages in step 10 are not +15 VDC, replace the Battery Charging assembly (p/o 53200-80003).

Normal battery operation

When the Option 300 battery is installed, it is normally turned ON when the counter is using AC power, as follows:

- 1 Press the **Utility** key and then the **Battery Option** softkey.

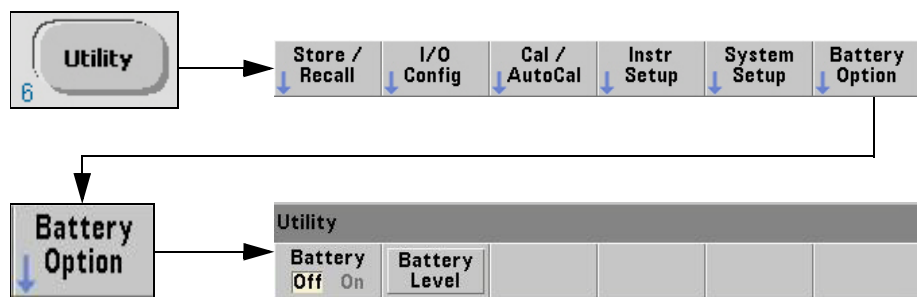

- 2 Press to select:
- Battery: **On** (When battery is Off, it is disabled but still available.)
- 3 Check the battery charge level by pressing the **Battery Level** softkey.
- Display shows (for example):

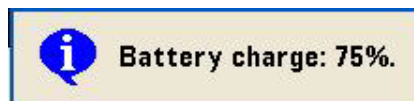

- A battery icon and/or an AC power plug can be seen at the top right-hand corner of the display, showing power connections and battery charge level:



NOTE

The battery should only be disabled (Off) when the counter is being stored and unused for an extended period of time. This will minimize battery drain.

When the battery is enabled and the counter is not connected to AC power, the battery is discharged at approximately 30% of full initial capacity per day. When the battery is disabled and not connected to AC power, the battery is discharged at approximately 10% of full initial capacity per month.

Batteries that are left fully discharged for 6-18 months may need to be replaced.

Remote battery commands

The battery charge can be read from a remote computer by sending the SCPI command: **SYSTem:BATTery:LEVel?** The charge level in % will be returned.

The counter can be queried to see if it is presently using AC power or battery power by sending the SCPI command: **SYSTem:BATTery:STATus?** The command returns either AC or BATT.

Performing the counter self-test

- 1 To access the counter Self-Test, press:
 - **[Utility] / (Instr Setup) / (Self Test)**

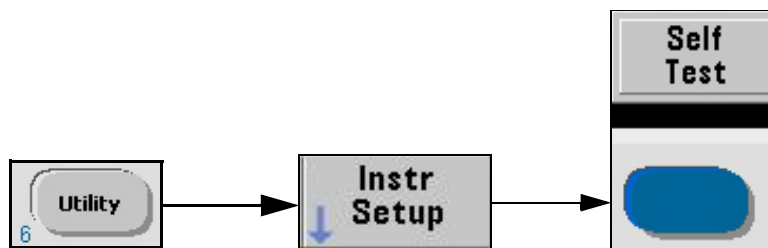

- 2 When the **Self Test** softkey is pressed:
 - The display shows: **Performing Self-Test. Please wait.**
 - After several seconds, the display shows: **Self-Test Passed.**

NOTE

If the self-test fails, an error message will be displayed (“Self-Test Failed.” To check for specific error messages, refer to the [Summary of remote self-test verification](#) below for information on how to read the error message(s) from a remote computer.

NOTE

If you do not have a remote computer available (requires a LAN, USB or GPIB interface) or are not proficient at programming, contact the nearest Keysight Service Center for information and help on sending the counter to Keysight for repair and/or calibration.

Summary of remote self-test verification

- Send command ***TST?**
- Wait 10 seconds.
- Retrieve query result:
 - 0 indicates the self-test PASSED.
 - Any value other than 0 indicates self-test FAILED.
- If the retrieved value is non-zero, read error queue: **SYSTem:ERRor?**
 - Read errors until no more errors.

NOTE

If you are able to read the error message(s), consult **“Error Messages”** on page 174 for what to do after receiving a specific calibration error message.

To determine the counter firmware version

Older firmware versions may have known or unknown problems in the code. Verify the firmware for your counter as follows:

- 1 Press the **Help** key, then the **About** softkey.

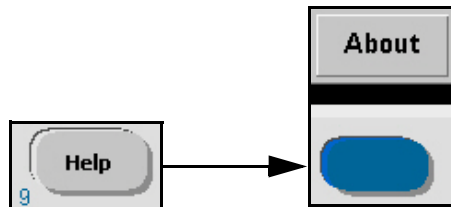

- 2 An information screen is displayed that contains the following:
- Keysight Model Number and counter Serial number
 - IP and GPIB addresses
 - Firmware Version (Format: x.xx - x.xx - xx - xx - xx)
 - Installed Options

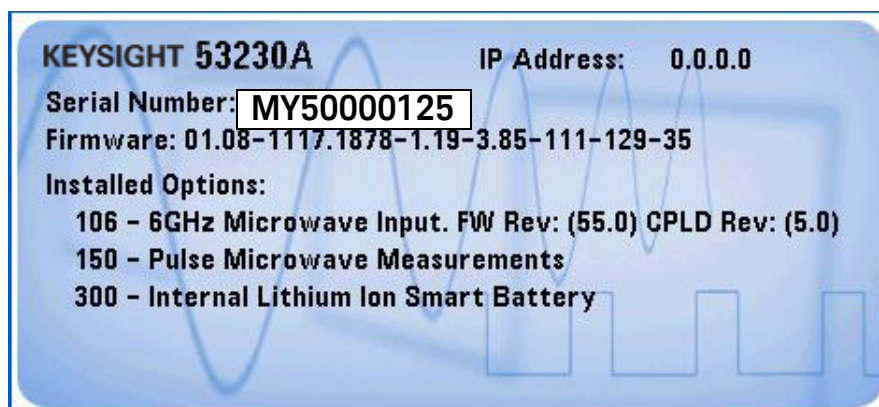
**NOTE**

The serial number prefix for your counter is the first 5 character positions in the serial number listed on the display (for example: MY50000125). The counter serial number suffix (for example: MY50000125) is the production number of the counter. The whole number (MY50000125) is the actual serial number of the counter.

NOTE

If any number other than 01.07 or 01.08 is displayed as the number before the first dash of the firmware version, then refer to [Chapter 6, "Backdating"](#) for any possible changes to the calibration procedures for other firmware versions.

NOTE

If the counter's firmware version code is 01.07 or 01.08, then perform the procedures in this section or contact Keysight Technologies about obtaining a firmware upgrade. (Refer to **"Obtaining repair service (world wide)"** on page 105.)

If the firmware is up-to-date and errors are still being reported, then continue with the following procedure. Refer as necessary to **"Error Messages"** on page 174.

Reseat the boards

Power off the unit, disconnect the power cord, and remove the cover. Re-seat the processor board, and the main board. Reinstall the cover, reconnect the power cord and power up the unit. Look for any errors still being reported after power-on.

Re-run the counter self test

Even if you ran the self-test previously, after reseating the boards the self-test should be run again. (Refer to [page 169](#).)

NOTE

After diagnosing an error or problem and isolating the failure to an assembly, refer to [Chapter 3, "Replacing Assemblies"](#) in this service guide for assembly removal and replacement procedures.

NOTE

After replacing an assembly, perform the calibration procedures in this chapter.

CAUTION

DO NOT swap the motherboard, the processor board, or the front panel board from one instrument to another. These boards contain model number and serial number information that uniquely identifies a specific unit, and boards that are mismatched to the instrument may result in problems with its performance, licensing, serviceability, importability/exportability or warranty. It is also likely that unpredictable error messages could occur. (See ["Error Messages"](#) on page 174.)

Error Messages

Some error messages may be caused by not having the latest firmware for the counter. Before assuming there is a hardware failure, check the firmware version in your counter and then contact Keysight using the procedure at the front of this service guide to determine if you need to update the firmware to a later version. Refer to **“To determine the counter firmware version”** on page 170.

If the counter has the latest firmware, and the error message(s) repeat, follow the recommended assembly replacement procedure.

The following error messages may appear during operation, calibration or testing of the 53210A, 53220A, or 53230A Counters. Refer to the appropriate category of error messages for problems you are experiencing with your counter.

NOTE

When information follows an error message, (1) is the most likely cause of the failure, and then (2), (3), etc. are the next most likely causes (in that order). Replace the indicated failed assembly. See **Chapter 3, “Replacing Assemblies”** and **Chapter 5, “Replaceable Parts”**.

Command errors (-100...)

These errors indicate operator errors. Refer to the User’s Guide for information.

Execution errors (-200...)

These errors (except for the following) indicate remote program command errors. Refer to the SCPI Programmer’s Guide for information.

Hardware errors (-240, -241, -250...)

- -240, "Hardware error; CPU board initialization failed"
 - (1) P0500-63001 processor board
- -240, "Hardware error; no communicate with measurement hardware"
 - (1) 532xx-66501 motherboard; (2) P0500-63001 processor board
- -240, "Hardware error; failed to program measurement FGCA security EEPROM"
 - (1) incorrect firmware match for this model number. Contact factory support to see if EEPROM U600 needs replacing (counter must be returned to factory).
- -240, "Hardware error; measurement hardware initialization failed"
 - (1) 532xx-66501 motherboard; (2) P0500-63001 processor board
- -240, "Hardware error; cannot communicate with channel 3 hardware"
 - (1) 53200-66505 (Option 106) or 53200-66506 (Option 115);
 - (2) 532xx-66501 motherboard
- -240, "Hardware error; channel 3 operation failed"
 - (1) 53200-66505 (Option 106) or 53200-66506 (Option 115);
 - (2) 532xx-66501 motherboard
- -240, "Hardware error; measurement operation failed"
 - (1) 532xx-66501 motherboard; (2) 53200-66505 (Option 106) or 53200-66506 (Option 115)
- -240, "Hardware error; GPIB interface failed"
 - (1) Remove the cover and check that the GPIB ribbon cable is fully seated;
 - (2) P0001-20001 GPIB board; (3) P0500-63001 processor board; (4) 532xx-66501 motherboard
- -241, "Hardware missing"
 - (1) GPIB, Internal Battery, or Channel 2/3 not installed
- -250, "Mass storage error: file read/write error"
 - (1) If USB, replace USB drive; (2) P0500-63001 Processor board

Device-specific errors (-300..., +800)

These error messages can be either operator information only, or can indicate a possible hardware failure.

- -310, "System error; internal software error"
 - (1) P0500-63001 Processor board
- -310, "System error; software initialization failed"
 - (1) P0500-63001 Processor board
- -310, "System error; out of memory"
 - (1) P0500-63001 Processor board
- -311, "Internal software error"
- -313, "Calibration memory lost"
 - (1) P0500-63001 Processor board
- -313, "Calibration memory lost; memory corruption detected"
 - (1) P0500-63001 Processor board
- -313, "Calibration memory lost; due to firmware revision change"
- -314, "Save/recall memory lost; memory corruption detected"
 - (1) P0500-63001 Processor board
- -314, "Save/recall memory lost; due to firmware revision change"
- -315, "Configuration memory lost; memory corruption detected"
 - (1) P0500-63001 Processor board
- -315, "Configuration memory lost; due to firmware revision change"
- -330, "Self-test failed"
- -350, "Error queue overflow"
- +800, "Nonvolatile memory write failure"
 - P0500-63001 processor board

Query errors (-400...)

These errors indicate licensing issues within the counter firmware. Refer to the User's Guide for information.

- +600, "Internal licensing error"
- +601, "License file corrupt or empty"
- +602, "No valid licenses found for this instrument"
- +603, "Some licenses could not be installed"
- +604, "License not found"

Calibration errors (700...)

The following errors indicate failures that may occur during a calibration and which are usually caused by the operator or by the external calibration source.

NOTE

If unable to determine the cause of a calibration error, run the counter self test to determine the instrument status:

- **[Utility] / (Instr Setup) / (Self Test)**
 - +701, "Calibration error; security defeated"
 - +702, "Calibration error; calibration memory is secured"
 - +703, "Calibration error; secure code provided was invalid"
 - +704, "Calibration error: secure code too long"
 - +705, "Calibration error; calibration aborted"
 - +706, "Calibration error: provided value out of range"
 - +707, "Calibration error: computed correction factor out of range"
 - +708, "Calibration error: signal measurement out of range"
 - +709, "Calibration error: no calibration for this function"
 - +710, "Calibration error: full scale correction out of range"

- +711, "Calibration error: calibration string too long"
- +712, "Calibration failed"
- +720, "Auto-calibration failed; input signal detected"
- +740, "Calibration data lost: secure state"
- +740, "Calibration information lost: count, security state, security code, string"
- +741, "Calibration data lost: string data"
- +742, "Calibration sata lost: corrections"
- +748, "Calibration memory write failure"

Self-test errors (901...)

Diagnosing the faulty assembly using self test errors 901 - 912

If the instrument reports self-test errors 901 - 912, this means the processor board is unable to correctly program or communicate with the FPGAs (programmable chips) on the main board. In this case, further troubleshooting is required to determine where the fault lies. The problem could be due to out of date firmware, unseated processor board or main board, assembly failure or processor board failure.

The following errors indicate failures that may occur during a self test:

- +901, "Self Test failed; Autocal failure"
 - (1) 53200-66501 Motherboard
- +902, "Self-test failed; Main CPU power supply out of range"
 - (1) 53200-66501 Motherboard
- +903, "Self-test failed; Real time clock settings lost"
 - (1) RTC 'coin' battery (CR2032); (2) 53200-66502 front panel assy
- +904, "Self-test failed; Main CPU error accessing boot env"
 - (1) P0500-63001 processor board
- +905, "Self-test failed; Failed to read FPGA Rev"
 - (1) 53200-66501 Motherboard; (2) P0500-63001 processor board
- +906, "Self-test failed; FPGA Rev is less than expected"

- +907, "Self-test failed; PIC communication failure"
 - (1) 53200-66501 Motherboard; (2) Battery; (3) P0500-63001 processor board
- +908, "Self-test failed; Battery Failed"
 - (1) 1420-0909 battery; (2) 53200-66507 battery charger assy
- +909, "Self-test failed; GPIB test Failed"
 - (1) P0001-20001 GPIB board; (2) P0500-63001 processor board
- +910, "Self-test failed; Channel 3 test failed"
 - (1) 53200-66505 (Option 106) or 53200-66506 (Option 115);
 - (2) 532xx-66501 motherboard
- +911, "Self-test failed; Front Panel revision check failed"
 - (1) 53200-66502 front panel; (2) P0500-63001 processor board
- +912, "Self-test failed; Measurement board test failed"
 - (1) 53200-66501 Motherboard; (2) P0500-63001 processor board

THIS PAGE HAS BEEN INTENTIONALLY LEFT BLANK.

3 Replacing Assemblies

Introduction	182
Tools Required	183
To Remove the Cover and Rear Bezel	185
To Remove the Internal DC Battery Assembly (Option 300)	187
To Remove the GPIB Assembly	189
To Remove a 6.0 GHz or 15.0 GHz Microwave Channel Assembly (Options 106/115)	190
To Remove the Processor Board	193
To Remove the Front Panel Assembly	194
To Remove the Motherboard	198
To Remove the AC Power Supply Assembly	199

Disassembly and reassembly.

Introduction

This chapter contains the instructions for removing major assemblies in the Keysight 53210A/53220A/53230A Counters. To install a new or repaired assembly, reverse the removal instructions.

This chapter provides the following disassembly/reassembly procedures:

- To remove the cover and rear bezel
- To remove the internal dc battery assembly (Option 300)
- To remove the gpib assembly
- To remove a 6.0 GHz or 15.0 GHz microwave channel assembly (Options 106/115)
- To remove the processor board
- To remove the front panel assembly
- To remove the display board, keypads, and window
- To remove the motherboard
- To remove the ac power supply assembly

CAUTION

Only open the counter at a Static-Safe Workstation to prevent electro-static damage to the instrument. Do not replace assemblies with the counter turned on or AC power connected to the instrument. Damage to components can occur.

CAUTION

DO NOT swap the motherboard, the processor board, or the front panel board from one instrument to another. These boards contain model number and serial number information that uniquely identifies a specific unit, and boards that are mismatched to the instrument may result in problems with its performance, licensing, serviceability, importability/exportability or warranty.

Tools Required

The following tools are required for these removal and replacement procedures:

- Hand TORX, 8 screwdriver (T8)
- Hand TORX, 10 screwdriver (T10)
- Hand TORX, 20 screwdriver (T20)
- 7-mm spin tight
- 14-mm deep-socket spin tight
- 1/4" spin tight
- 5/16" open end wrench
- Static-Safe Workstation

Do this first

Before performing any of the removal and replacement procedures, the following steps must be performed.

- 1** Turn counter off.
- 2** Remove AC line power cord from the rear AC line socket.

WARNING

Hazardous voltages are on the power supply assembly. After unplugging the instrument, wait at least 6 minutes for the capacitors on the power supply assembly to discharge before working on the instrument.

- 3** Open up the counter only at a static-safe workstation.

Electrostatic discharge

CAUTION

Electronic components and assemblies in the Keysight 53210A, 53220A, and 53230A Counters can be permanently degraded or damaged by electrostatic discharge. Humans can accumulate static electricity charges of several thousand volts on their skin or clothes (harmless to them) but which can discharge through sensitive semi-conductor circuits causing permanent damage. Use the following precautions when installing or replacing assemblies:

- 1 DO ensure that static-sensitive devices or assemblies are handled only at a static-safe work station that provides proper grounding for service personnel.
- 2 DO ensure that static-sensitive devices or assemblies are placed or stored in static shielding bags or containers.
- 3 DO ensure that you are wearing a static-safe wristband that is grounded to the mat and to earth ground.
- 4 DO NOT wear clothing subject to static-charge buildup, such as wool or synthetic materials.
- 5 DO NOT remove an assembly or component from its static shielding protection until you are ready to install it.
- 6 DO NOT handle components or assemblies in carpeted areas.
- 7 AVOID touching component leads. (Handle by packaging only.)

Surface mount repair

Surface mount components should only be removed using soldering irons or desoldering stations *expressly designed* for surface mount components. Use of conventional solder removal equipment will almost always result in permanent damage to the printed circuit board and will void your Keysight Technologies factory warranty. This instrument is not intended to be repaired by replacing individual components, only assemblies.

To Remove the Cover and Rear Bezel

The following steps are for removing the cover and rear bezel. The cover is removed to access the board and cable assemblies, and all other internal parts.

WARNING

When the cover is removed from the instrument, line voltages are exposed, which are dangerous and may cause serious injury if touched. Disconnect power and wait 6 minutes before starting.

- 1 Turn off the counter and remove the power cord.
- 2 Remove the handle by rotating it to the vertical position and pulling the ends outward as shown in [Figure 3-1](#).

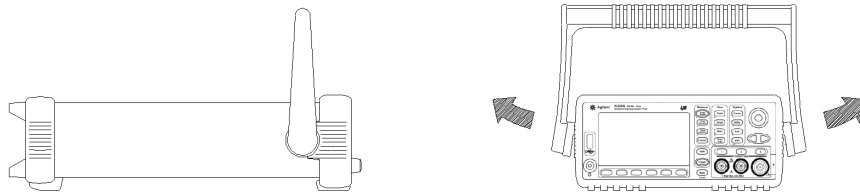

Figure 3-1 Handle removal

3 Replacing Assemblies

- 3 To remove the rear bezel and cover, loosen the captive screws on the sides as shown in **Figure 3-2**, using the TORX 20 screwdriver.

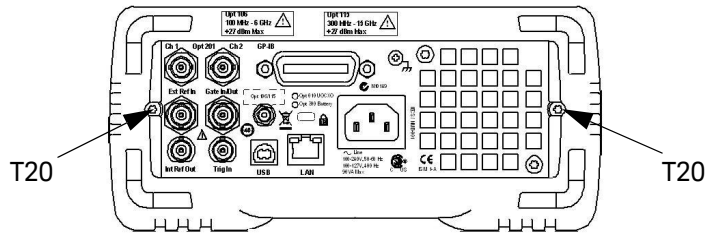

Figure 3-2 Rear Bezel And Cover Removal

- 4 With one hand gripping the front bezel, pull the rear bezel and cover off with the other hand by sliding the cover backward.

To Remove the Internal DC Battery Assembly (Option 300)

- 1** Remove the cover and rear bezel from the counter as described previously.
- 2** Remove the two T20 TORX screws from the left hand side of the counter that secure the battery to the frame.
- 3** Lift upwards on the two tabs holding the battery assembly on top of the left side panel and slide the battery assembly off the three large tabs that hold it against the AC Power Supply Assembly.
- 4** Without disconnecting the battery charging cable, carefully turn the battery assembly over on its back and insert the three smaller tabs behind the large tabs into the three slots in the assembly. (See [Figure 3-3](#).)
- 5** Disconnect the Y-Cable (3 connectors) from the Option 300 Battery Assembly, then disconnect the digital cable.
- 6** Remove the Battery Assembly. If the battery is to be replaced, remove the four T10 TORX screws holding the battery cover.
- 7** Lift the battery and its cover free of the battery connector. Push the battery out of the aluminum cover. Insert the new battery in the cover and re-install the battery into the charging assembly.
- 8** Re-install the new battery and/or charging assembly into the counter by reversing the above procedure. Be sure to re-connect the cables to the assembly, digital cable *first*.

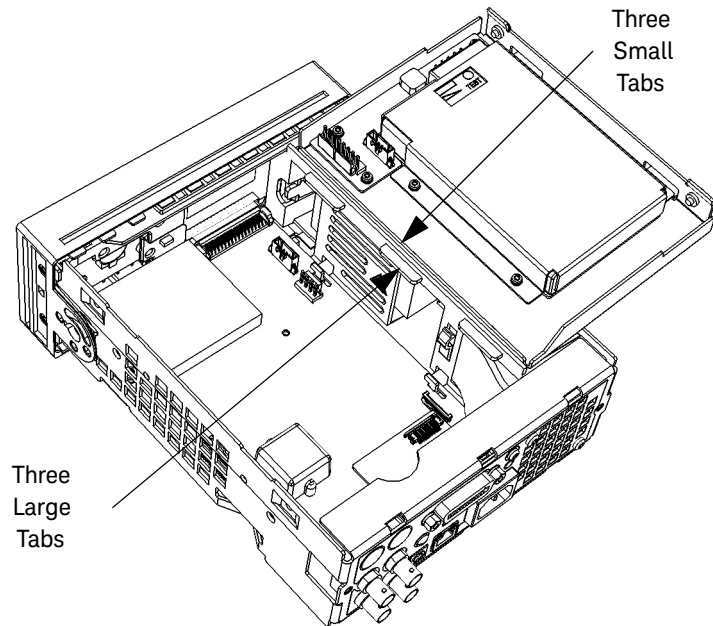

Figure 3-3 Battery assembly temporary position for service or Removal

To Remove the GPIB Assembly

- 1 Remove the cover and rear bezel from the counter as described previously.
- 2 If installed, remove the Option 300 Internal DC Battery assembly as described previously.
- 3 Carefully remove the ribbon cable from J1 on the GPIB printed circuit board.
- 4 Using a 7mm spintite, remove the two hex screws securing the GPIB assembly to the rear panel.
- 5 Remove the GPIB assembly from the counter.
- 6 To replace the GPIB assembly, reverse the above procedure.

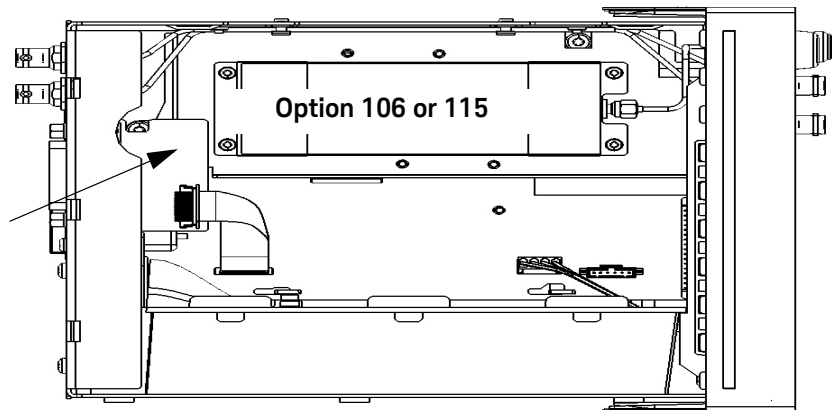

Figure 3-4 Top view of counter showing GPIB assembly

To Remove a 6.0 GHz or 15.0 GHz Microwave Channel Assembly (Options 106/115)

- 1 Remove the cover and rear bezel from the counter as described previously.
- 2 If installed, remove the Option 300 Internal DC Battery assembly as described previously.
- 3 If installed, remove the GPIB assembly as described previously.
- 4 Remove the Option 106 or 115 Microwave Channel assembly as follows:
 - a Remove the two flathead screws on the left-hand aluminum side panel that secure the aluminum bracket of the microwave channel assembly to the side panel.
 - b Using a 5/16" open-end wrench, loosen the semi-rigid coax cable (at the assembly end of the cable) that connects the assembly to the front or rear panel.
 - c Remove the T20 TORX screw at the rear of the motherboard that secures the channel assembly to the motherboard.
 - d Lift up carefully on the microwave channel assembly and disconnect the ribbon cable on the underside of the assembly.
 - e Remove the assembly from the counter, being careful not to damage any cables or components.
- 5 To replace the microwave assembly, use the following procedure.

Re-installing the microwave channel assembly

CAUTION

When re-installing a microwave channel assembly, care must be taken to not put undue stress on the semi-rigid cable.

NOTE

The front flange on the right-front of the microwave channel assembly bracket must rest on the tab protruding from the front panel (see [Figure 3-5](#)).

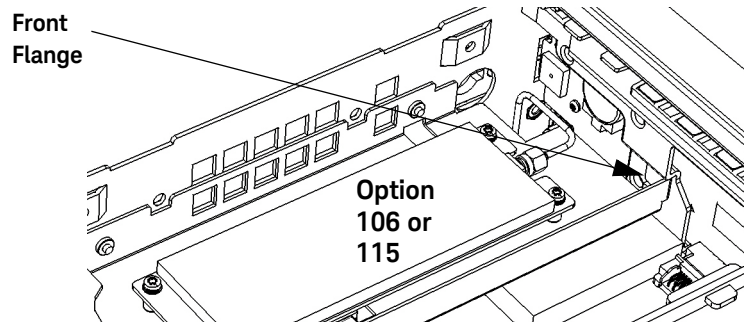

Figure 3-5 Front flange resting on plastic tab

- 1 Line up the semi-rigid SMA cable male connector and the microwave channel assembly SMA female edge connector, connect them together and loosely tighten the SMA connector.

NOTE

Be sure the flange on the front of the assembly remains positioned over the tab on the front panel assembly.

- 2 Re-install the T20 TORX screw, securing the rear flange on the microwave channel bracket to the motherboard. Do not tighten the screw all the way down at this time.

NOTE

(Front Panel Input Channel Connector) If the semi-rigid cable connectors do not line up exactly without distorting the cable, turn the chassis over and, through the open area provided, use a 5/16" wrench to loosen the SMA connector on the semi-rigid cable where it connects to the front panel and gently re-position the cable until it is positioned to connect the assembly to the front panel, with no stress on either end of the semi-rigid cable.

NOTE

(Rear Panel Input Channel Connector) If the semi-rigid cable connectors do not line up exactly without distorting the cable, loosen the 5/16" nut on the outside rear panel SMA connector and gently re-position the cable until it is positioned to connect the assembly to the rear panel, with no stress on either end of the semi-rigid cable.

- 3** Use a 5/16" open-end wrench to secure the SMA connectors at each end of the semi-rigid cable. Do not overtighten.
- 4** Install the two flathead screws through the holes in the left-hand aluminum side panel into the embedded nuts on the bracket of the Channel 2 assembly and tighten.
- 5** Tighten the T20 TORX screw.

NOTE

After installing either the 6 GHz or the 15 GHz Microwave Channel assembly, perform the calibration procedure in [Chapter 2](#) for that assembly. For the 53210A Counter, the assembly is Channel 2. For the 53220A and 53230A Counters, the assembly is Channel 3.

To Remove the Processor Board

- 1 Remove the cover and rear bezel as described previously.
- 2 Turn the chassis upside down. On the bottom of the motherboard, remove the T10 TORX screw that secures the smaller processor printed circuit board to the motherboard (see [Figure 3-6](#)).

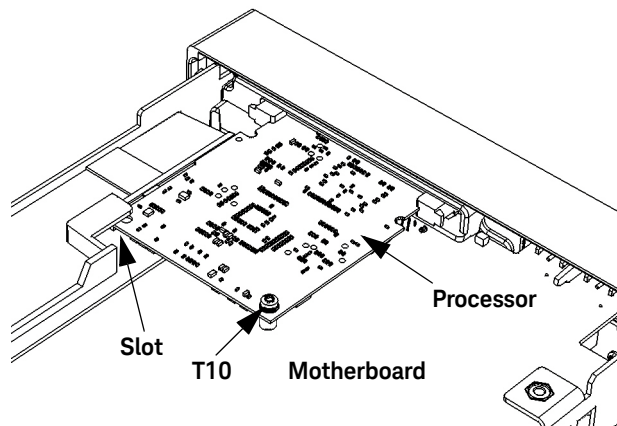

Figure 3-6 Processor PC board

NOTE

For re-assembly, note how the left rear corner of the processor board fits into its slot (above the small plastic standoff inside the slot) to hold the board horizontal.

- 3 Press the two tabs securing the edge connector of the processor board to release the board.
- 4 Remove the processor board carefully from its connector and set it aside in a safe location on the ESD mat.
- 5 To re-install the processor board, reverse the above procedure.

To Remove the Front Panel Assembly

- 1 Remove the cover and rear bezel from the counter as described previously.
- 2 If installed, remove the Option 300 Internal DC Battery assembly as described previously.
- 3 If installed, remove the GPIB assembly as described previously.
- 4 If installed, remove the Option 106 or 115 Microwave Channel assembly as described previously.
- 5 To remove the front rubber bumper, stretch a corner and then slide it off as shown in [Figure 3-7](#).



Figure 3-7 Front rubber bumper removal

- 6 Remove the front panel assembly as follows:

NOTE

Read each instruction step in its entirety, while examining the hardware and referring to the appropriate figure(s), before proceeding with the step. This will acquaint you completely, in advance, with the action to be performed. The actions in some steps must be accomplished simultaneously to succeed. Read all nearby NOTES carefully.

- 7 Turn the chassis upside down. Remove the smaller processor board from the motherboard as described previously (see [Figure 3-6](#)).
- 8 Remove the board carefully from its edge connector and set it aside in a safe location on the ESD mat.

- 9 Turn the counter chassis upright and position the counter as shown in [Figure 3-8](#).
- 10 Remove the T20 TORX screw on the front left-hand side of the motherboard as shown in [Figure 3-8](#).

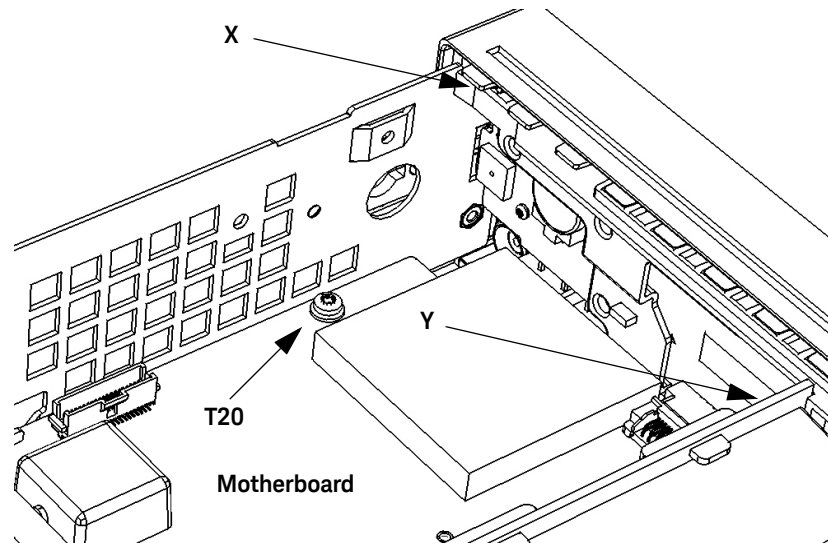

Figure 3-8 Front panel removal

NOTE

The four standoffs on the aluminum side panels (two on each side, front) secure the front panel into the four holes cut out on the plastic sides of the front panel (two on each side). The next steps free the standoffs from the holes so the front panel assembly can be removed.

- 11 With your right hand, press in on the plastic tab (X on [Figure 3-8](#)) at the top left front of the front panel, while at the same time, use your left hand to press in on the front of the left-hand aluminum chassis side-panel, so that the front of the side-panel overlaps the depressed tab and keeps it depressed. The left front standoffs should now be free of their holes.

- 12 On the middle front right-hand side of the front panel, pull the plastic tab (Y on [Figure 3-8](#)) carefully toward the rear of the chassis and simultaneously press in on the right side panel of the aluminum chassis until the front panel is partially released. The right front standoffs should now be free of their holes.

NOTE

At this point, the front panel is only held to the motherboard by an edge connector.

- 13 Using gentle pressure on both sides of the front panel, push the front panel away from the motherboard to release the edge connector and free the front panel completely.

NOTE

The Lithium-Ion 'coin' battery (CR2032) on the rear of the display board may now be easily accessed and replaced, if necessary. Symptoms of a discharged CR2032 battery needing replacement are when the Real Time Clock does not maintain real time correctly after the AC power cable is removed from the counter. If Option 300 is installed, the Real Time Clock should continue to update correctly even if the AC power cord is disconnected, regardless of the charge status of the CR2032.

- 14 To replace the front panel, reverse the above procedure.

To remove the display assembly from the front panel

- 1** The following procedure removes the display assembly from the front panel.
- 2** Using a T8 TORX screwdriver, loosen the six T8 screws holding the plastic cover over the rear of the display board. Carefully lift the cover off (leaving the screws in their places) and set it aside.
- 3** The knob on the front panel is only pressed onto its rotor. It can be removed by pulling gently on two sides.
- 4** Using a thin, non-sharp round tool, such as a folded-open metal paperclip, slip one end of the clip under the bronze-colored ribbon cable passing through a slot on the display board and connected to J202. Gently force the ribbon cable end out of J202.
- 5** Remove the last T8 TORX screw holding the display board to the front panel and carefully remove the display board.
- 6** To replace the display board with a new assembly, reverse the above procedure. Be sure the ribbon cable is passed through the slot and gets re-connected to J202.

To Remove the Motherboard

- 1 Remove the cover and rear bezel from the counter as described previously.
- 2 If installed, remove the Option 300 Internal DC Battery assembly as described previously.
- 3 If installed, remove the Option 106 or 115 Channel assembly as described previously.
- 4 Remove the Processor board as described previously.
- 5 Remove the Front Panel assembly as described previously.
- 6 The following procedure completes the removal of the motherboard:
 - a Disconnect the two-wire (red/black) fan connector at the right-rear of the motherboard (J1201).
 - b Disconnect the four-wire (2 red/2 black) power supply connector at the right-front of the motherboard (J1000).
 - c Using a 14mm deep socket, remove the lock nut and lockwasher from the **Ext Ref In** and **Gate In/Out** BNC connectors on the rear panel.
 - d Remove the T20 TORX screw at the rear-center of the motherboard.
 - e Slide the motherboard forward until the three locking tabs (two on the right side and one on the left side) are centered in their locking slots. Lift the motherboard up away from the tabs and slide it the rest of the way clear of the mainframe.
- 7 To replace the motherboard, reverse the above procedure.

To Remove the AC Power Supply Assembly

- 1** After the motherboard is removed, the AC Power Supply may now be removed as follows:
- 2** Disconnect the power ground wire spade connector, the 3-pin AC power-IN connector, and the 6-pin DC power-OUT connector from the AC power supply.
- 3** Remove the T20 TORX screw holding the rear of the power supply to the right hand side of the frame.
- 4** Slide the power supply assembly forward until the five locking tabs clear their slots, and remove the power supply assembly.
- 5** To replace the AC Power Supply, reverse the above procedure.

THIS PAGE HAS BEEN INTENTIONALLY LEFT BLANK.

4 Retrofitting Options

Introduction	202
To Retrofit Ultra-High Stability Timebase (Option 010)	204
To Retrofit the GPIB Connector	205
To Retrofit the Internal Battery DC Power (Option 300)	207
To Retrofit the 53210A (Channel 1) or 53220A/53230A (Channels 1/2) Rear Panel Inputs (Option 201)	213
To Retrofit the 53210A Channel 2 Front Panel Input (Option 106 or Option 115, plus Front Panel Option 202)	217
To Retrofit the 53210A Channel 2 Rear Panel Input, 6.0 GHz (Option 106) or 15.0 GHz (Option 115) plus Rear Panel Option 203	227
To Retrofit the 53220A/53230A Channel 3 Input, 6.0 GHz (Option 106) or 15.0 GHz (Option 115) plus Front panel option 202	232
To Retrofit the 53220A/53230A Channel 3 Input, 6.0 GHz (Option 106) or 15.0 GHz (Option 115) plus Rear Panel Option 203	242
To Retrofit Option 150 (Pulse Microwave Measurements) for the 53230A	247

Introduction

This chapter provides the following retrofit procedures:

- To retrofit ultra-high stability timebase (Option 010)
- To retrofit the GPIB connector
- To retrofit the internal battery DC power (Option 300)
- To retrofit the 53210A (channel 1) or 53220A/53230A (channels 1/2) rear panel inputs (Option 201)
- To retrofit the 53210A channel 2 front panel input (Option 106 or Option 115, plus front panel Option 202)
- To retrofit the 53210A channel 2 rear panel input, 6.0 GHz (Option 106) or 15.0 GHz (Option 115) plus rear panel Option 203
- To retrofit the 53220A/53230A channel 3 input, 6.0 GHz (Option 106) or 15.0 GHz (Option 115) plus front panel Option 202
- To retrofit the 53220A/53230A channel 3 input, 6.0 GHz (Option 106) or 15.0 GHz (Option 115) plus rear panel Option 203
- To retrofit Option 150 (pulse microwave measurements) to the 53230A

Tools required

The following tools may be needed for these retrofitting procedures:

- Hand TORX, 8 screwdriver (T8)
- Hand TORX, 10 screwdriver (T10)
- Hand TORX, 20 screwdriver (T20)
- 7-mm spintight (GPIB connector screws)
- 14-mm deep-socket or deep spintight (Type N and BNC connectors)
- 1/4" spintight (Option 115 standoffs)
- 5/16" open-end wrench (SMA connectors)
- Long-nose Pliers
- 3/16" or 1/4" wide medium slot screwdriver

Do This first

NOTE

Before performing any of the retrofit procedures in Chapter 4, the following steps must be performed.

- 1 Turn counter off.
- 2 Remove ac line power cord from the rear ac line socket.

WARNING

Hazardous voltages exist on some internal circuits of the counter. After disconnecting the AC line power cord, wait at least 6 minutes for the high-voltage capacitors to discharge before removing the cover.

- 3 Except for factory-installed Option 010 (Ultra-high stability timebase) and Option 150 (Pulse microwave measurements), disconnect the Option 300 internal battery, if installed, as described in each retrofit procedure.
- 4 To prevent Electrostatic Discharge (ESD) damage to the counter, place the counter on a static-safe mat that is grounded to earth ground.

CAUTION

ESD damage caused by customer access to the internal circuits of the counter without proper ESD protection may void the instrument warranty.

- 5 Ensure that you are wearing a static-safe wristband that is grounded to the mat and to earth ground.

CAUTION

DO NOT swap the motherboard, the processor board, or the front panel board from one instrument to another. These boards contain model number and serial number information that uniquely identifies a specific unit, and boards that are mismatched to the instrument may result in problems with its performance, licensing, serviceability, importability/exportability or warranty.

To Retrofit Ultra-High Stability Timebase (Option 010)

NOTE

Retrofitting to Option 010 (Ultra-High Stability Timebase) must be performed by technicians at an Keysight Technologies Service Center. Refer to the list of Keysight Sales and Service offices in the Appendix for the office closest to you.

NOTE

To order the Ultra-High Stability Option 010, you will need to place an order with Keysight for 53200U-010 and identify which counter you have (53210A, 53220A, or 53230A).

To Retrofit the GPIB Connector

GPIB connector parts (P/N 53200U-400)

Item	Keysight part no.	Qty.
PC board assembly	P0001-63001	1
Ribbon cable, 16-pin	53200-61601	1
7mm Hex-head standoff	0380-0644	2
Washer, lock	2190-0577	2

Preliminary steps

CAUTION

Before proceeding with the installation, follow all the ESD steps as outlined in the section titled **Do This first** under the **Introduction** at the beginning of Chapter 4 of this service guide.

- 1 Remove the cover as follows:

NOTE

Refer as necessary to the figures in the section titled **“To Remove the Cover and Rear Bezel”** on page 185.

- 2 To remove the counter handle, rotate the handle to the vertical (90 degree) position and pull outward on the two side arms.
- 3 Using a T20 TORX screwdriver, loosen the two T20 TORX screws securing the rear panel bezel.
- 4 Slide the outside cover of the counter to the rear and remove the cover.

- 5 If installed, disconnect and move the Option 300 Internal Battery DC Power Assembly out of the way as follows (refer to the figures in “To Remove the Internal DC Battery Assembly (Option 300)” on page 187, as needed):
 - Remove the two T20 TORX screws and lockwashers holding the Option 300 assembly to the left-hand side panel (as viewed from the rear of the instrument).
 - Lift up carefully on the left side of the assembly and remove the assembly from the three large tabs holding it on the right side. It is not necessary to disconnect the two cables going to the assembly.
 - Lay the assembly on its back to the right side of the chassis and place the three small tabs on the back side of the three large tabs into the three slots on the assembly deck.

GPIB connector installation procedure

- 1 Remove the GPIB cover plate using a T20 TORX screwdriver.
- 2 Insert the GPIB connector through the connector hole on the rear panel.
- 3 Use a 7mm spin-tite to install the two supplied Hex-head standoffs and lock washers. Tighten the two standoffs securely (do not over-tighten).
- 4 Connect one end of the supplied 16-pin ribbon cable to connector J901 on the motherboard chassis.

NOTE

Be sure the non-insulated side of the pins on the cable is facing the pins in the motherboard connector to provide electrical contact.

- 5 Connect the other end of the ribbon cable to J1 on the GPIB printed circuit assembly.
- 6 Re-install the Option 300 Internal Battery DC Power Assembly (if removed). Be sure the cables are connected.
- 7 Re-install the cover by performing the cover removal procedure (Preliminary Steps 1-4), in reverse.

To Retrofit the Internal Battery DC Power (Option 300)

Option 300 DC power input assembly parts

Item	Keysight part no.	Qty.
Battery charger PCB assembly	53200-66507	1
Battery	1420-0909	1
Y-Cable	53200-61602	1
Ribbon cable, 6-pin	53200-61603	1
Deck	53200-00601	1
Cover	53200-00602	1
TORX 10 screws	0515-0430	7
TORX 20 screws	0515-0433	2

Preliminary steps

CAUTION

Before proceeding with the installation, follow all the ESD steps as outlined in the section titled **Do This first** under the **Introduction** at the beginning of Chapter 4 of this service guide.

- 1 Remove the cover as follows:

NOTE

Refer as necessary to the figures in the section titled **“To Remove the Cover and Rear Bezel”** on page 185 of this guide.

- 2 To remove the counter handle, rotate the handle to the vertical (90 degree) position and pull outward on the two side arms.
- 3 Using a T20 TORX screwdriver, remove the two T20 TORX screws securing the rear panel bezel.

- 4 Slide the outside cover of the counter to the rear and remove the cover.

Battery assembly installation procedure

- 1 Using a medium slot-head screwdriver, gently push back the 4-pin connector lock tab on the motherboard end of the jumper cable that connects between the Motherboard (J1000) and the PowerSupply board (J2). Refer to [Figure 4-1](#) and [Figure 4-2](#).

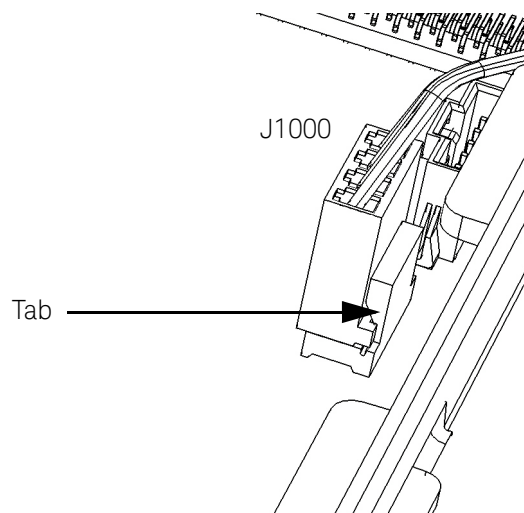

Figure 4-1 Connector Locking Tab

- 2 Gently move the cable 4-pin connector side-to-side while pulling upward on the cable connector until the jumper cable is free from the motherboard.
- 3 Repeat steps 1 and 2 for the other end of the jumper cable where it connects to the AC power supply assembly (6-pin connector) on the side wall of the instrument. See [Figure 4-2](#). Set the jumper cable aside in a safe location in case it is needed in the future.

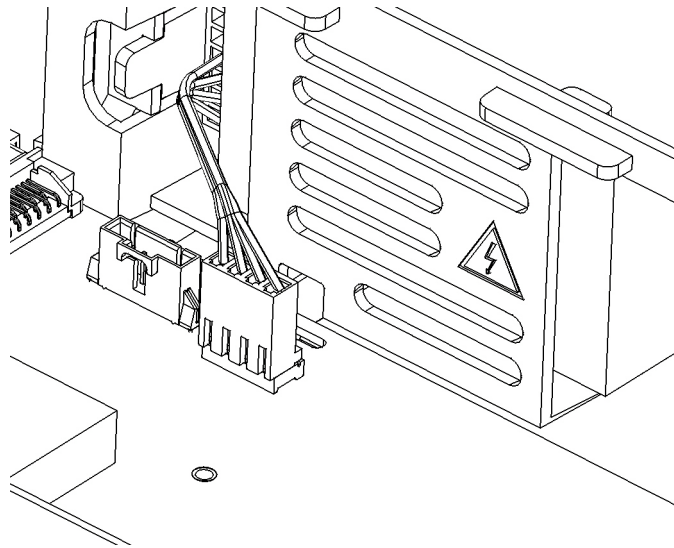

Figure 4-2 Jumper cable installed

- 4** Next, connect the 6-pin connector on the supplied Y-cable assembly (Figure 4-3) to the AC power supply 6-pin connector, and then connect the 4-pin connector on the cable to the motherboard 4-pin connector where the jumper cable was removed in step 2.
- 5** Be sure the locking tabs on the PC board connectors lock the cable connectors at each end, preventing the cable connectors from working loose on their own.

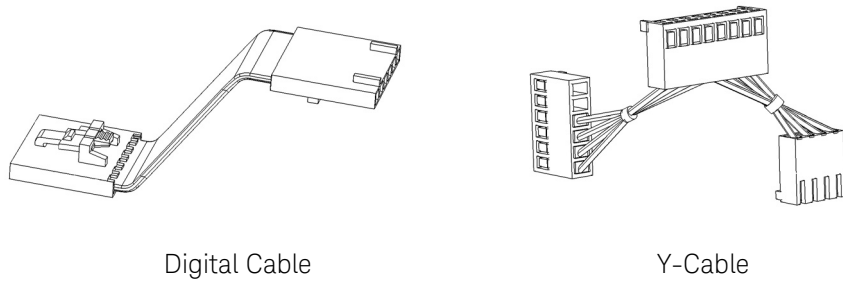

Figure 4-3 Digital and Y-cables.

- 6 Connect one end of the supplied (digital) 6-pin ribbon cable (Figure 4-3) to the 6-pin connector J1200 (next to the 4-pin connector J1000 on the motherboard).
- 7 Push and hold the white test button on the battery while observing the charge-level indicator (Figure 4-4). The charge level should be at least 25%. It should charge to between 75% and 100% after installation when AC power is applied to the counter.

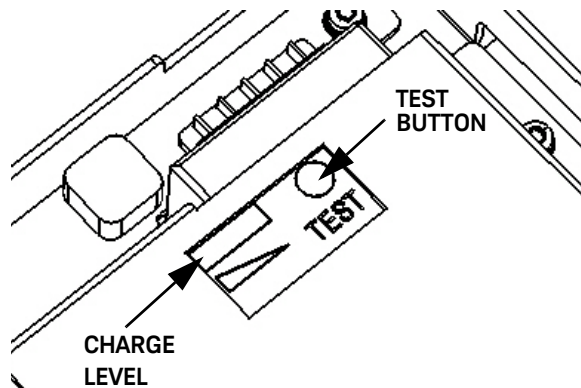

Figure 4-4 Test button and charge indicator

- 8 Set the Battery assembly on its back on the right-hand side of the chassis and insert the three small plastic tabs on the chassis into the three slots on the assembly deck. Now, first connect the digital cable (just installed) to the battery charger assembly 6-pin (J101) PC board connector. Next, connect the 8-pin cable to (J100). (See [Figure 4-5](#).)

NOTE

Be sure the lock tabs on the PC board connectors lock the cable connectors at their ends, preventing the cable connectors from working loose on their own.

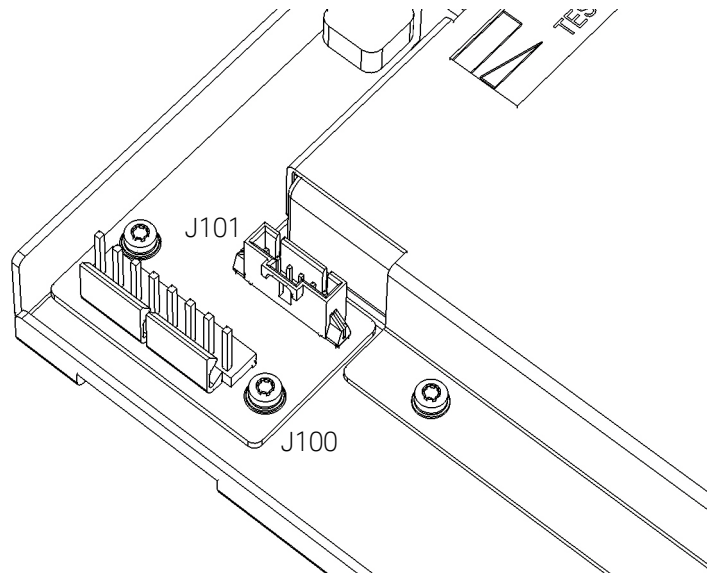

Figure 4-5 Battery assembly connectors

- 9 Move the whole assembly from the three small tabs and insert the three large tabs on the plastic AC power supply cover into the three slots on the battery assembly deck shown in [Figure 4-6](#).
- 10 Press the opposite side of the battery assembly down until the two tabs on the battery assembly deck rest in the the cutouts of the chassis side panel.

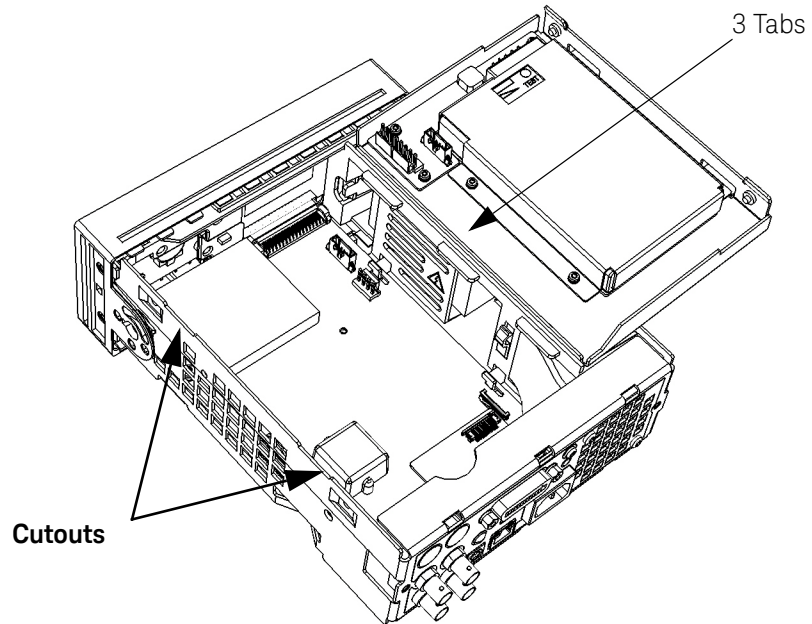

Figure 4-6 Battery assembly held by three small tabs

- 11** Install the supplied TORX T20 screws and lockwashers (2 each) through the provided chassis holes into the imbedded nuts in the battery deck and secure.
- 12** Re-install the cover by performing the cover removal procedure (Preliminary Steps 1 through 4), in reverse.

To Retrofit the 53210A (Channel 1) or 53220A/53230A (Channels 1/2) Rear Panel Inputs (Option 201)

Option 201 rear panel channel 1/2 parts

Item	Keysight part no.	Qty.
RF input cable	53200-61611	2
Cable clamp	1400-0116	4
Lock washer	2190-0699	2
Hex Nut	2940-0256	2

NOTE

Each single channel uses half of the listed quantities.

Preliminary steps

NOTE

Before proceeding with the installation, follow all the ESD steps as outlined in the section titled **Do This first** under the **Introduction** at the beginning of Chapter 4 of this service guide.

1 Remove the instrument cover as follows:

NOTE

Refer as necessary to the illustrations in the section titled **“To Remove the Cover and Rear Bezel”** on page 185 of this guide.

2 To remove the counter handle, rotate the handle to the vertical (90 degree) position and pull outward on the two side arms.

- 3** Using a T20 TORX screwdriver, loosen the two T20 TORX screws securing the rear panel bezel.
- 4** Slide the outside cover of the counter to the rear and remove the cover.
- 5** If installed, disconnect and move the Option 300 Internal Battery DC Power Assembly out of the way as follows (refer to the figures in [Chapter 3, "To Remove the Internal DC Battery Assembly \(Option 300\)"](#), as needed):
 - Remove the two T20 TORX screws and lockwashers holding the Option 300 assembly to the left-hand side panel (as viewed from the rear of the instrument).
 - Lift up carefully on the left side of the assembly and separate the assembly from the three large tabs holding it on the right side.
 - Lay the assembly on its back to the right side of the chassis and place the three small tabs (on the back side of the three large tabs) into the three slots on the assembly deck. Disconnect the two cables going to the assembly.
- 6** If installed, move the Option 106/115 channel 2 assembly (53210A) or channel 3 assembly (53220A/53230A) out of the way as follows (refer to the figures in [Chapter 3, "To Remove a 6.0 GHz or 15.0 GHz Microwave Channel Assembly \(Options 106/115\)"](#), as needed):
 - Remove the T20 TORX screw and lockwasher at the rear end of the Option 106/115 aluminum deck.
 - Remove the two flathead screws that secure the assembly to the side panel.
 - Using a 5/16" open end wrench, loosen the SMA connector on the end of the semi-rigid cable that is connected to the PC board.
 - Slide the Option 106/115 assembly to the rear of the chassis, as necessary, to expose the two gold-connectors at the front of the motherboard near the front panel (J101 and J201).

Channels 1/2 rear panel retrofit procedure

- 1 For each of the channels being added, proceed as follows:

NOTE

Channel 1 only for the 53210A, or Channels 1 and 2 for the 53220A/53230A.

- 2 Connect the gold-colored push-on connector end of the supplied RF cable to the appropriate connector on the motherboard close to the front panel. (J201 is on the left.) Refer to [Figure 4-7](#).
- 3 Channel 1 connects to J101 and Channel 2 connects to J201 on the motherboard. If both channels 1 and 2 are being installed, the cables will cross between the rear panel and the motherboard.

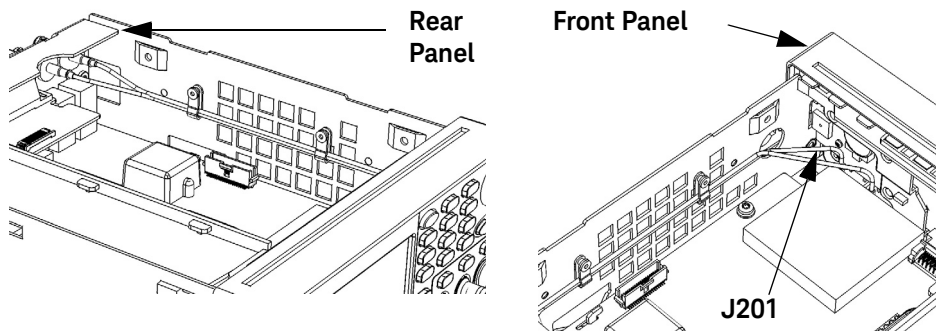

Figure 4-7 Option 201 rear input channels 1 and 2

- 4 If it was necessary to move an installed Option 106/115 assembly, re-install it now. The Option 201 cables will go over the top of the Option 106/115 assembly but under the Option 300 assembly (if these are installed).

NOTE

The performance of the option 106/115 must be re-verified after it has been re-installed.

- 5 Remove the rear panel plug(s) for the Channel(s) being installed.
- 6 Insert the BNC connector end of the RF cable (over the top of the Option 106/115 assembly) through the appropriate channel cutout hole in the rear panel.
- 7 Using a 14 mm deep-socket or spintite, secure the connector with the included hex nut and lockwasher (do not overtighten).
- 8 If necessary, repeat steps 2 through 7 for Channel 2.
- 9 Install the supplied cable clamp(s) as shown in [Figure 4-7](#).

NOTE

When Option 201 is installed (Channels 1 and 2 rear panel BNC connectors), the front panel connector performance for RF Channels 1 and 2 is not specified. The rear panel connector for each channel IS specified according to the information in <http://literature.cdn.keysight.com/litweb/pdf/5990-6283EN.pdf>.

- 10 If the Option 300 Internal Battery was removed at the beginning of this procedure, re-install it now. Be sure to re-connect the cables.
- 11 Re-install the cover by performing the cover removal procedure (Preliminary Steps 1-4), in reverse.

To Retrofit the 53210A Channel 2 Front Panel Input (Option 106 or Option 115, plus Front Panel Option 202)

Option 106/115 channel 2 parts

Item	Keysight part no.	Qty.
6.0 GHz assembly (Option 106)	53200-66505	1
15.0 GHz assembly (Option 115)	53200-66506	1
Ribbon cable, 40-pin	53200-61605	1
Labels, 6 GHz	53200-84301	2
Labels, 15 GHz	53200-84302	2
Standoff (Option 115 only)	0380-5091	2
Bracket, aluminum	53200-00603	1
TORX 10 screws	0515-0430	4
Screws, flathead	0515-1946	2
Screw (Option 115 only)	0515-3131	12

Option 202 front panel channel 2 parts

Item	Keysight part no.	Qty.
Type N-to-SMA Connector-Adapter	E4418-20009	1
RF cable, front, SMA semi-rigid	53200-61604	1
Washer plate (with "LIFT" tab)	E4418-00016	1
14 mm Hex nut	2950-0132	1
Hole Plug	6960-0076	1

NOTE

After the installation of Option 106 or 115, a complete microwave frequency calibration must be performed. Refer to [Chapter 2](#) for the procedure.

Preliminary steps

NOTE

Before proceeding with the installation, follow all the ESD steps as outlined in the section titled [Do This first](#) under the [Introduction](#) at the beginning of Chapter 4 of this service guide.

- 1 Remove the instrument cover as follows:

NOTE

Refer as necessary to the illustrations in the section titled ["To Remove the Cover and Rear Bezel"](#) on page 185 of this guide.

- 2 To remove the counter handle, rotate the handle to the vertical (90 degree) position and pull outward on the two side arms.
- 3 Using a T20 TORX screwdriver, loosen the two T20 TORX screws securing the rear panel bezel.
- 4 Slide the outside cover of the counter to the rear and remove the cover.
- 5 If installed, disconnect and move the Option 300 Internal Battery DC Power Assembly out of the way as follows (refer to the figures in [Chapter 3, "To Remove the Internal DC Battery Assembly \(Option 300\)"](#), as needed):
 - Remove the two T20 TORX screws and lockwashers holding the Option 300 assembly to the left-hand side panel (as viewed from the rear of the instrument).
 - Lift up carefully on the left side of the assembly and separate the assembly from the three large tabs holding it on the right side.
 - Lay the assembly on its back to the right side of the chassis and place the three small tabs (on the back side of the three large tabs) into the three slots on the assembly deck. Disconnect the two cables going to the assembly.

6 Assemble the parts in the Option 106/115 package as follows:

NOTE

Refer as necessary to **Figure 4-8**.

- If Option 115 is being installed, insert and tighten the two supplied standoffs (using a 1/4" spintite) in the two **middle** holes closest to the **rear** flange of the Channel 2 assembly (Front Panel Option 202 only).
- Position the PC board over the aluminum bracket so that the SMA edge connector is pointed toward the front flange (without the hole) and sits on top of the standoffs.
- Install 4 (Option 106) or 6 (Option 115) T10 TORX screws to secure the PC board to the aluminum deck.

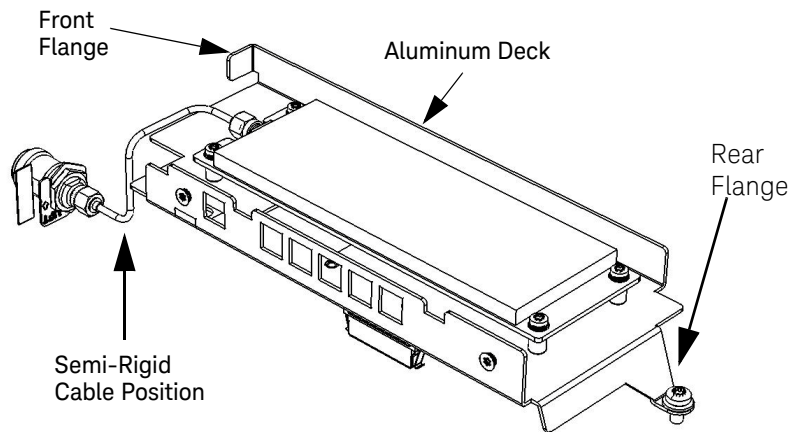

Figure 4-8 53210A channel 2 front panel Option 106/202

Channel 2 front panel retrofit procedure (53210A)

- 1 Remove the front panel assembly as follows:

NOTE

Read each instruction step in its entirety, while examining the hardware and referring to the appropriate figure(s), before proceeding with the step. This will acquaint you completely, in advance, with the action to be performed. The actions in some steps must be accomplished simultaneously to succeed. Read all nearby NOTES carefully.

- 2 Turn the chassis upside down. On the bottom of the motherboard, remove the T10 TORX screw that secures the smaller Processor board to the motherboard (see [Figure 4-9](#)).

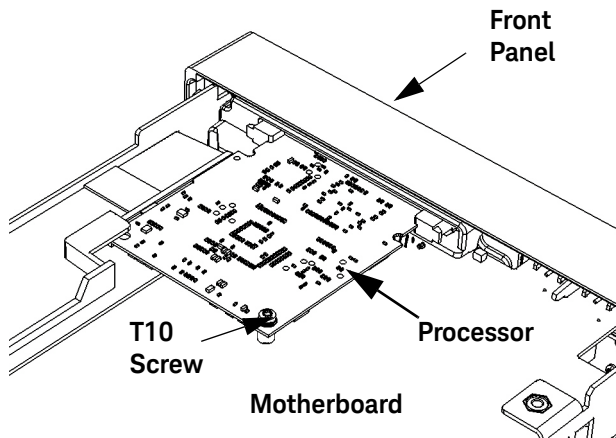

Figure 4-9 Processor printed circuit board

- 3 Note how the left rear corner of the processor board fits into its slot (above the small plastic standoff inside the slot) to hold the board horizontal. Press the two tabs securing the edge connector of the processor board to release the board.
- 4 Remove the processor board carefully from its connector and set it aside in a safe location on the ESD mat.

- 5 Turn the counter chassis upright and position the counter as shown in [Figure 4-10](#).
- 6 Remove the T20 TORX screw on the front left-hand side of the motherboard as shown in [Figure 4-10](#).

NOTE

The four standoffs on the aluminum side panels (two on each side, front) secure the front panel into the four holes cut out on the plastic sides of the front panel (two on each side). The next steps free the standoffs from the holes so the front panel can be removed.

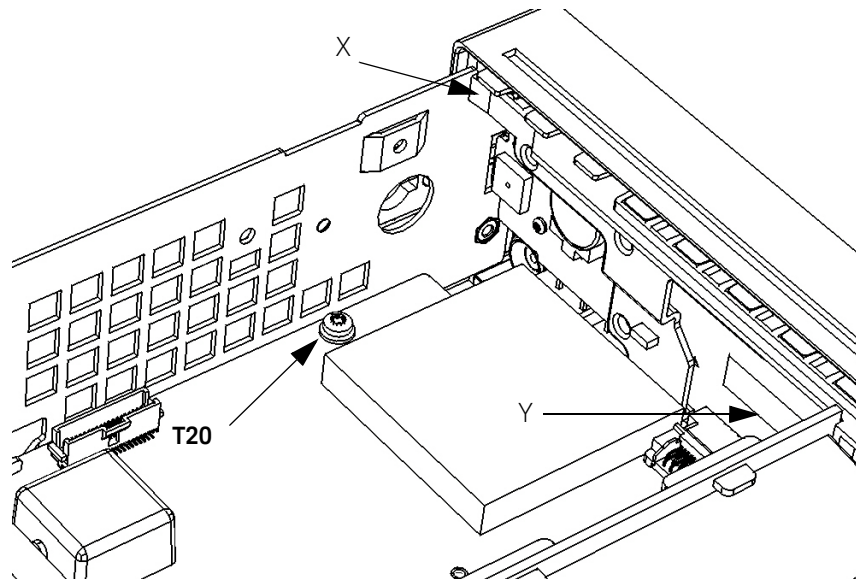

Figure 4-10 T20 TORX screw on motherboard

- 7 With your right hand, press in on the plastic tab (X on [Figure 4-10](#)) at the top left front of the front panel, while at the same time, use your left hand to press in on the front of the left-hand aluminum chassis side-panel, so that the front of the side-panel overlaps the depressed tab and keeps it depressed. The left front standoffs should now be free of their holes.

- 8 On the middle front right-hand side of the front panel, pull the plastic tab (Y on [Figure 4-10](#)) carefully toward the rear of the chassis and simultaneously press in the right side panel of the aluminum chassis until the front panel is partially released. The right front standoffs should now be free of their holes.

NOTE

At this point, the front panel is only held to the motherboard by an edge connector.

- 9 Using gentle pressure on both sides of the front panel, push the front panel away from the motherboard to release the edge connector and free the front panel completely.
- 10 Insert the typeN-to-SMA connector-adapter into the Channel 2 hole on the front panel (remove the hole-plug, if necessary), so that the typeN connector is on the front side of the front panel.
- 11 On the back side of the connector-adapter, place the washer plate and the 14mm hex nut over the SMA connector and secure. See [Figure 4-11](#).
- 12 Make sure the word "LIFT" is visible on the washer-plate and that the "LIFT" tab on the washer-plate is not underneath the hex nut.

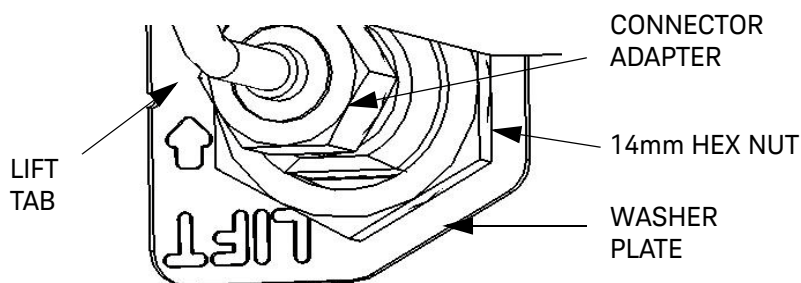

Figure 4-11 Connector-adapter installation

- 13 Pull up slightly on the "LIFT" tab on the washer-plate so that the tab blocks the hex nut from coming unscrewed after installation.
- 14 Connect the supplied semi-rigid cable to the SMA connector on the connector-adapter. Finger-tighten the connector so that the cable is positioned to connect to the Channel 3 assembly as shown in [Figure 4-8](#) and [Figure 4-12](#). Do not tighten the nut with a wrench yet.

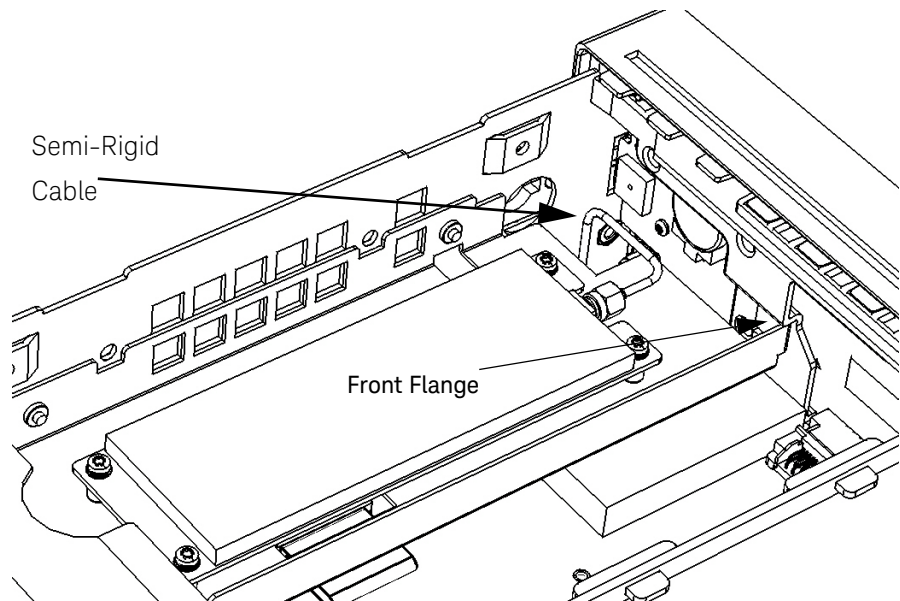

Figure 4-12 Semi-rigid cable position

15 Re-install the front panel as follows:

NOTE

Carefully guide the semi-rigid cable into the chassis through the opening provided while installing the front panel onto the motherboard.

16 Line up the edge connector pins on the motherboard with the edge connector on the front panel and carefully press the front panel onto the motherboard.

NOTE

The four standoffs on the aluminum side panels (two on each side) must lock into the four holes cut out on the plastic sides of the front panel (two on each side).

NOTE

Be sure that the right-hand side tab (see step 8 above) locks the side panel in place. It may be necessary to gently press outward on the right-hand side panel until the tab locks into place.

17 Re-install the T20 TORX screw removed in step 6 above.

18 Re-install the processor board on the underside of the motherboard (removed in steps 2-4 above) as follows (refer to [Figure 4-9](#)):

- Insert the rear left-hand corner of the PC board in the horizontal slot (as viewed from above) and then line up the edge connector pins on the PC board with the edge connector on the underside of the front panel.

NOTE

Verify that the processor board is parallel horizontally with the motherboard. The rear left-hand corner must sit on top of the small standoff inside the slot.

- Press in carefully on the rear edge of the PC board until the edge connector tabs lock into place.
- Install the T10 TORX screw through the hole in the P500 board into the standoff on the motherboard (screw removed in step 2 above).

19 Turn the chassis upright. Install the Option 106 or 115 Channel 2 assembly as follows:

20 Remove the T20 TORX screw at the rear of the motherboard.

21 Connect one end of the supplied 40-pin ribbon cable to J900 on the motherboard. Connect the other end to J401 on the underside of the Channel 2 assembly.

22 Set the Channel 2 assembly down on top of the motherboard so that the female SMA edge connector is near the male SMA connector of the semi-rigid cable installed on the front panel assembly (see [Figure 4-13](#)).

NOTE

The front flange on the right-front of the Channel 2 assembly bracket must rest on the tab protruding from the front panel (see [Figure 4-13](#)).

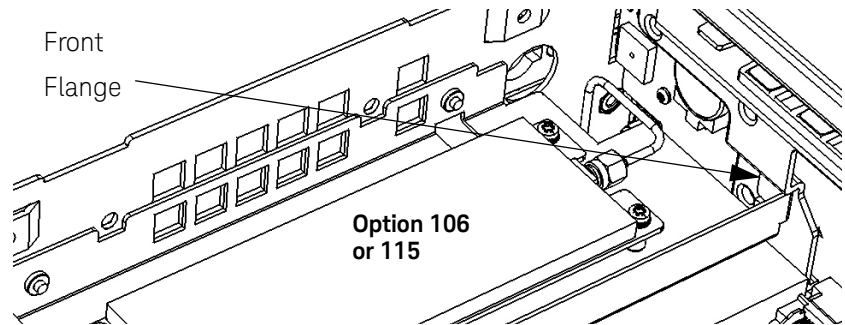

Figure 4-13 Front flange resting on plastic tab

- 23** Line up the semi-rigid SMA cable male connector and the Channel 2 assembly SMA female edge connector, connect them together and loosely tighten the SMA connector.

NOTE

Be sure the flange on the front of the Channel 2 assembly remains positioned over the tab on the front panel assembly.

- 24** Re-install the T20 TORX screw removed in step 19 above, securing the rear flange on the Channel 2 bracket to the motherboard with the screw. Do not tighten the screw all the way down at this time.

NOTE

If necessary, turn the chassis over and, through the open area provided, loosen the SMA connector on the semi-rigid cable where it connects to the front panel and gently re-position the cable until it is positioned to connect the assembly to the front panel, with no stress on the semi-rigid cable.

- 25** Use a 5/16" open-end wrench to secure the two SMA connectors at each end of the semi-rigid cable. Do not overtighten.
- 26** Install the two supplied flathead screws through the holes in the left-hand aluminum side panel into the embedded nuts on the bracket of the Channel 2 assembly.
- 27** Tighten the T20 TORX screw (step 23 above).

4 Retrofitting Options

- 28** If removed previously, re-install the Option 300 Internal Battery Assembly. Be sure to re-connect the cables.
- 29** Re-install the cover by performing the cover removal procedure (Preliminary Steps 1-4), in reverse.
- 30** Attach the supplied Option 106 or 115 label alongside the front panel type N connector in the depression provided.

To Retrofit the 53210A Channel 2 Rear Panel Input, 6.0 GHz (Option 106) or 15.0 GHz (Option 115) plus Rear Panel Option 203

Option 106/115 channel 2 parts

Item	Keysight part no.	Qty.
6.0 GHz assembly (Option 106)	53200-66505	1
15.0 GHz assembly (Option 115)	53200-66506	1
Ribbon cable, 40-pin	53200-61605	1
Labels, 6 GHz	53200-84301	2
Labels, 15 GHz	53200-84302	2
Standoff (Option 115 only)	0380-5091	2
Bracket, aluminum	53200-00603	1
TORX 10 screws	0515-0430	4
Screws, flathead	0515-1946	2
Screw (Option 115 only)	0515-3131	12

Option 203 rear panel channel 2 parts

Item	Keysight part no.	Qty.
RF Cable, rear, SMA semi-rigid	53200-61606	1
Retainer	53200-40002	1
Hole plug	53200-40001	1
Screw, self-tapping	0515-5220	1

NOTE

After the installation of Option 106 or 115, a complete Microwave Frequency Calibration must be performed. Refer to [Chapter 2](#) for the procedure.

Preliminary steps

CAUTION

Before proceeding with the installation, follow all the ESD steps as outlined in the section titled **Do This first** under the **Introduction** at the beginning of Chapter 4 of this service guide.

- 1 Remove the instrument cover as follows:

NOTE

Refer as necessary to the illustrations in the section titled **“To Remove the Cover and Rear Bezel”** on page 185 of this guide.

- 2 To remove the counter handle, rotate the handle to the vertical (90 degree) position and pull outward on the two side arms.
- 3 Using a T20 TORX screwdriver, loosen the two T20 TORX screws securing the rear panel bezel.
- 4 Slide the outside cover of the counter to the rear and remove the cover.
- 5 If installed, move the Option 300 Internal Battery DC Power Assembly out of the way as follows (refer to the figures in **Chapter 3, “To Remove the Internal DC Battery Assembly (Option 300)”**, as needed):
 - Remove the two T20 TORX screws and lockwashers holding the Option 300 assembly to the left-hand side panel (as viewed from the rear of the instrument).
 - Lift up carefully on the left side of the assembly and separate the assembly from the three large tabs holding it on the right side.
 - Lay the assembly on its back to the right side of the chassis and place the three small tabs on the back side of the three large tabs into the three slots on the assembly deck. Refer to **Figure 4-6**. Disconnect the two cables going to the battery assembly.
- 6 Assemble the parts in the Option 106/115 package as follows:

NOTE

Refer as necessary to **Figure 4-14**.

- If Option 115 is being installed, insert and tighten the two supplied standoffs (using a 1/4" spintite) in the two **middle** holes closest to the **front** flange of the Channel 2 assembly (Rear Panel Option 203 only).
- Position the printed circuit board over the aluminum bracket so that the SMA edge connector is pointed toward the rear flange (with the hole in it) and sits on top of the standoffs.
- Install 4 (Option 106) or 6 (Option 115) T10 TORX screws to secure the printed circuit board to the aluminum deck.

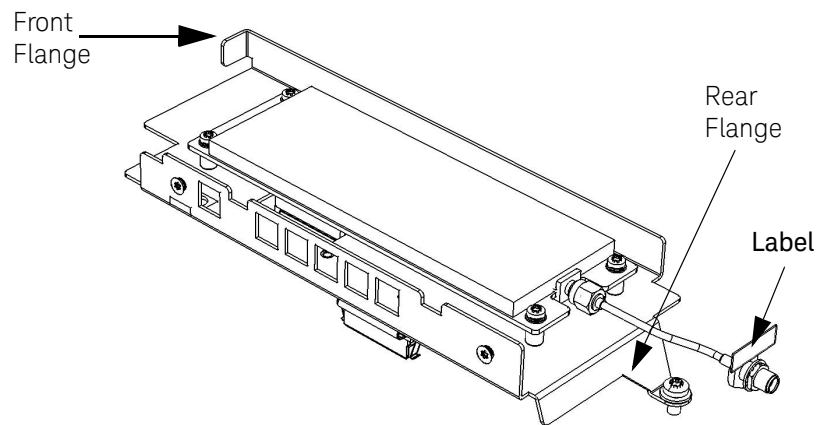

Figure 4-14 53210A channel 2 rear panel Option 106/203

Channel 2 rear panel retrofit procedure (53210A)

- 1 Install the Channel 2 PC assembly as follows:
- 2 Remove the T20 TORX screw at the rear of the motherboard.
- 3 Connect one end of the supplied 40-pin ribbon cable to J900 on the motherboard. Connect the other end to J401 on the underside of the Channel 2 PC board assembly.
- 4 Set the Channel 2 assembly down on top of the motherboard so that the SMA edge connector is towards the rear panel. The front flange on the right-front of the Channel 2 assembly bracket must rest on the tab protruding from the front panel (see [Figure 4-15](#)).

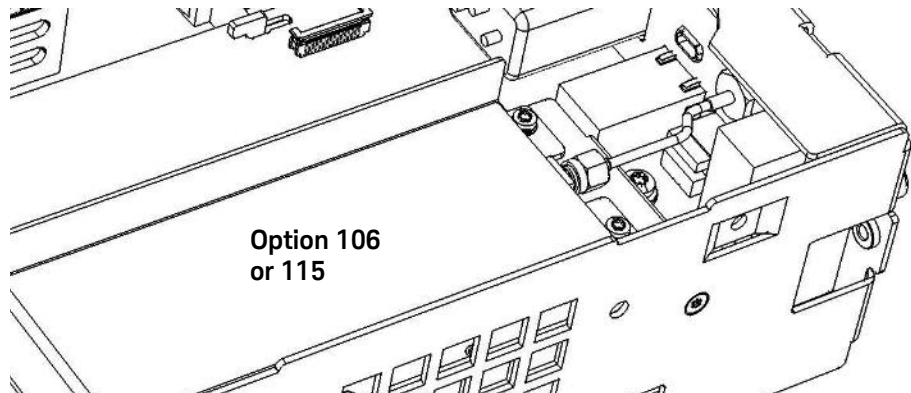

Figure 4-15 Channel 2 assembly installed on top of the motherboard, with the SMA edge connector pointing toward the rear of the counter.

- 5 Re-install the T20 TORX screw removed in step 2 above, securing the rear flange on the Channel 2 assembly to the motherboard with the screw.
- 6 Install the two supplied flathead screws through the holes in the left-hand aluminum side panel into the embedded nuts on the bracket of the Channel 2 assembly.

- 7** Install the supplied SMA semi-rigid cable as follows:
 - Insert the end of the supplied semi-rigid cable with the female SMA connector through the hole on the rear panel marked "Opt 106/115".
 - Line up the male SMA cable connector on the other end of the semi-rigid cable and the Channel 2 assembly SMA edge connector, connect them together and tighten the SMA cable connector using a 5/16" wrench.
 - Secure the rear panel SMA connector with the supplied 5/16" hex nut and lockwasher. Do not overtighten.

NOTE

Be sure there is no stress on the semi-rigid cable.

- 8** If removed previously, re-install the Option 300 Internal Battery Assembly. Be sure to re-connect the cables.
- 9** Re-install the cover by performing the cover removal procedure (Preliminary Steps 1-4), in reverse.
- 10** Install the supplied Option 106 or 115 label above the rear panel SMA connector in the location provided.

To Retrofit the 53220A/53230A Channel 3 Input, 6.0 GHz (Option 106) or 15.0 GHz (Option 115) plus Front panel option 202

Option 202 front panel channel 3 parts

Item	Keysight part no.	Qty.
Type N-to-SMA connector-adapter	E4418-20009	1
Washer-plate (with "LIFT" tab)	E4418-00016	1
14mm Hex nut	2950-0132	1
Hole plug	6960-0076	1
6.0 GHz Assembly (Option 106)	53200-66505	1
15.0 GHz assembly (Option 115)	53200-66506	1
RF cable, front, SMA semi-rigid	53200-61604	1
Ribbon cable, 40-pin	53200-61605	1
Labels, 6 GHz	53200-84301	2
Labels, 15 GHz	53200-84302	2
Standoff (Option 115 only)	0380-5091	2
Bracket, aluminum	53200-00603	1
TORX 10 screws	0515-0430	4
Screws, flathead	0515-1946	2
Screw (Option 115 only)	0515-31311	2

NOTE

After the installation of Option 106 or 115, a complete microwave frequency calibration must be performed. Refer to [Chapter 2](#) for the procedure.

Preliminary steps

CAUTION

Before proceeding with the installation, follow all the ESD steps as outlined in the section titled **Do This first** under the **Introduction** at the beginning of Chapter 4 of this service guide.

- 1 Remove the instrument cover as follows:

NOTE

Refer as necessary to the illustrations in the section titled **"To Remove the Cover and Rear Bezel"** on page 185 of this guide.

- 2 To remove the counter handle, rotate the handle to the vertical (90 degree) position and pull outward on the two side arms.
- 3 Using a T20 TORX screwdriver, loosen the two TORX-head screws securing the rear panel bezel.
- 4 Slide the outside cover of the counter to the rear and remove the cover.
- 5 If installed, disconnect and move the Option 300 Internal Battery DC Power Assembly out of the way as follows (refer to the figures in **Chapter 3, "To Remove the Internal DC Battery Assembly (Option 300)"**, as needed):
 - Remove the two T20 TORX screws and lockwashers holding the Option 300 assembly to the left-hand side panel (as viewed from the rear of the instrument).
 - Lift up carefully on the left side of the assembly and remove the assembly from the three large tabs holding it on the right side.
 - Lay the assembly on its back to the right side of the chassis and place the three small tabs on the back side of the three large tabs into the three slots on the assembly deck. Disconnect the two cables going to the assembly.

6 Assemble the parts in the Option 106/115 package as follows:

NOTE

Refer as necessary to **Figure 4-16**.

- If Option 115 is being installed, insert and tighten the two supplied standoffs (using a 1/4" spintite) in the two **middle** holes closest to the **rear** flange of the Channel 2 assembly (Front Panel Option 202 only).
- Position the PC board over the aluminum bracket so that the SMA edge connector is pointed toward the front flange (without the hole) and sits on top of the standoffs.
- Install 4 (Option 106) or 6 (Option 115) T10 TORX screws to secure the PC board to the aluminum deck.

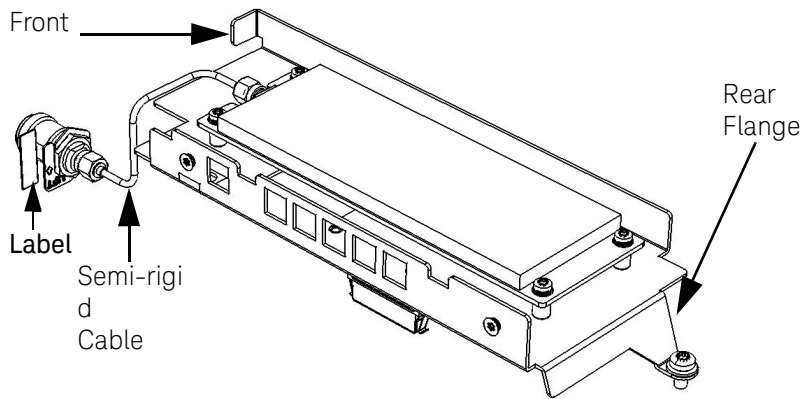

Figure 4-16 53220A/53230A Option 106/202.

Front panel installation procedure (Option 202 only)

- 1 Remove the front panel assembly as follows:

NOTE

Read each instruction step in its entirety, while examining the hardware and referring to the appropriate figure(s), before proceeding with the step. This will acquaint you completely, in advance, with the action to be performed. The actions in some steps must be accomplished simultaneously to succeed. Read all nearby NOTES carefully.

- 2 Turn the chassis upside down. On the bottom of the motherboard, remove the T10 TORX screw that secures the smaller processor board to the motherboard (see [Figure 4-17](#)).

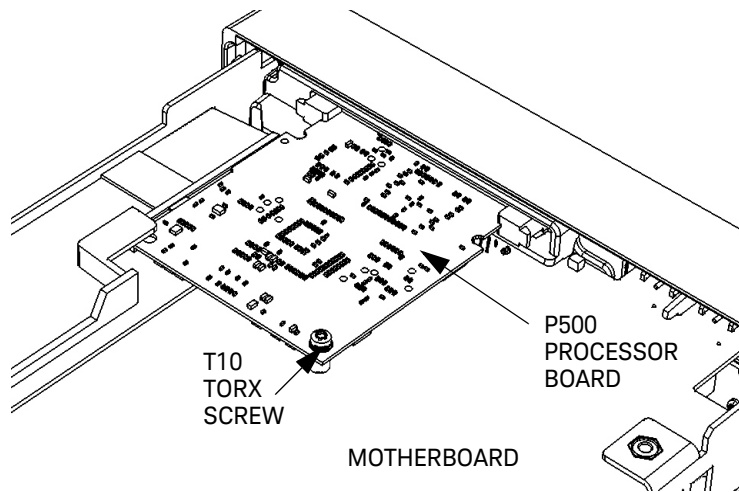

Figure 4-17 Processor printed circuit board.

NOTE

For re-installation, note how the left rear corner fits into its slot (above the small plastic standoff inside the slot) to hold the board horizontal.

- 3 Press the two tabs securing the edge connector of the processor board to release the board.
- 4 Remove the processor board carefully from its connector and set it aside in a safe location on the ESD mat.
- 5 Turn the counter chassis upright and position the counter as shown in [Figure 4-18](#).
- 6 Remove the T20 TORX screw on the front left-hand side of the motherboard as shown in [Figure 4-18](#).

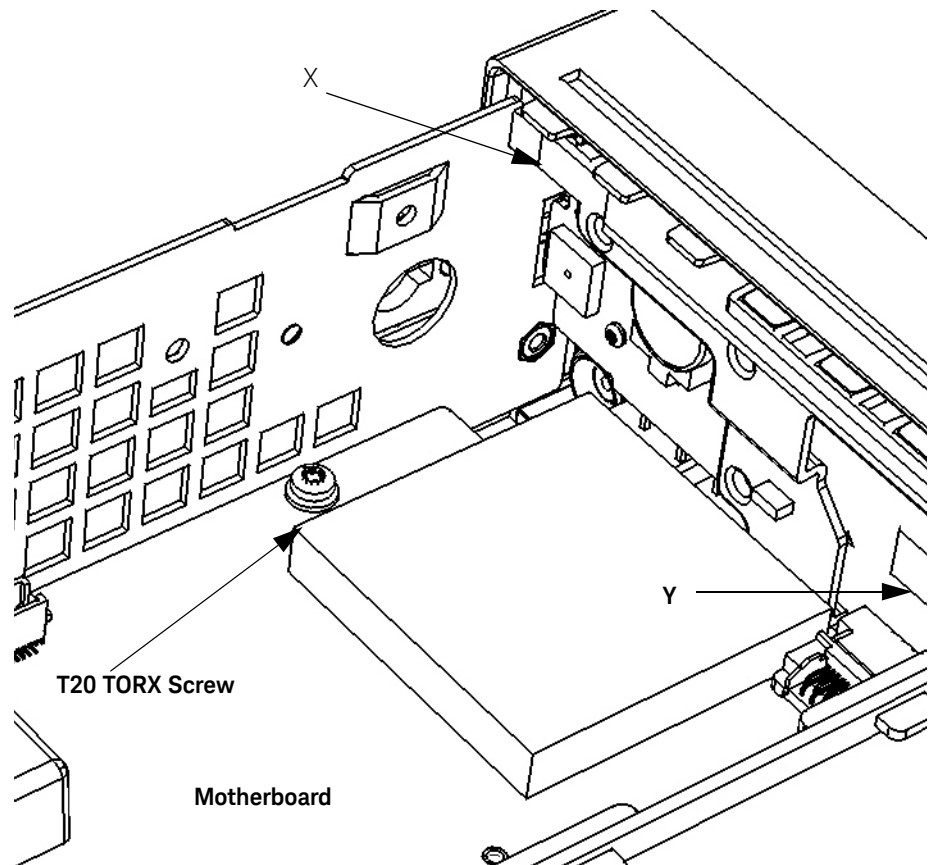

Figure 4-18 T20 TORX screw on motherboard

NOTE

The four standoffs on the aluminum side panels (two on each side, front) secure the front panel into the four holes cut out on the plastic sides of the front panel (two on each side). The next steps free the standoffs from the holes so the front panel can be removed.

- 7 With your right hand, press in on the plastic tab (X on [Figure 4-18](#)) at the top left front of the front panel, while at the same time, use your left hand to press in on the front of the left-hand aluminum chassis side-panel, so that the front of the side-panel overlaps the depressed tab and keeps it depressed.
- 8 On the middle front right-hand side of the front panel, pull the plastic tab (Y on [Figure 4-18](#)) carefully toward the rear of the chassis and simultaneously press in the right side panel of the aluminum chassis until the front panel is partially released.

NOTE

At this point, the front panel is only held to the motherboard by an edge connector.

- 9 Using gentle pressure on both sides of the front panel, push the front panel away from the motherboard to release the edge connector and free the front panel completely.
- 10 Insert the typeN-to-SMA connector-adapter into the Channel 3 hole on the front panel (remove the hole-plug, if necessary), so that the typeN connector is on the front side of the front panel.
- 11 On the back side of the connector-adapter, place the washer plate and the 14mm hex nut over the SMA connector and secure. See [Figure 4-19](#).

NOTE

Make sure the word "LIFT" is visible on the washer-plate and that the "LIFT" tab on the washer-plate is not underneath the hex nut when it is tightened.

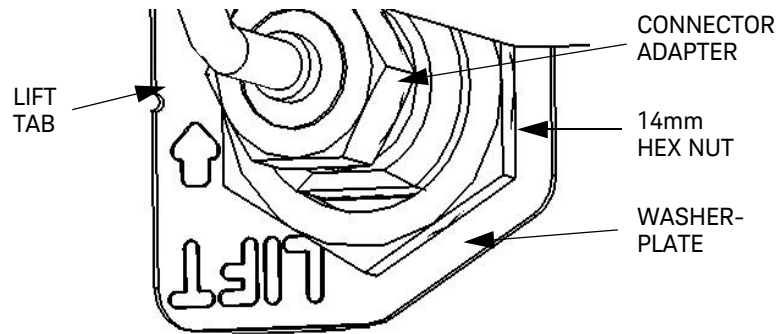

Figure 4-19 Connector-adapter parts

- 12** Pull up slightly on the "LIFT" tab on the washer-plate so that the tab blocks the hex nut from coming unscrewed after installation.
- 13** Connect the supplied semi-rigid cable to the SMA connector on the connector-adapter. Finger-tighten the connector so that the cable is positioned to connect to the Channel 3 assembly as shown in [Figure 4-16](#) and [Figure 4-20](#). Do not tighten the nut with a wrench yet.

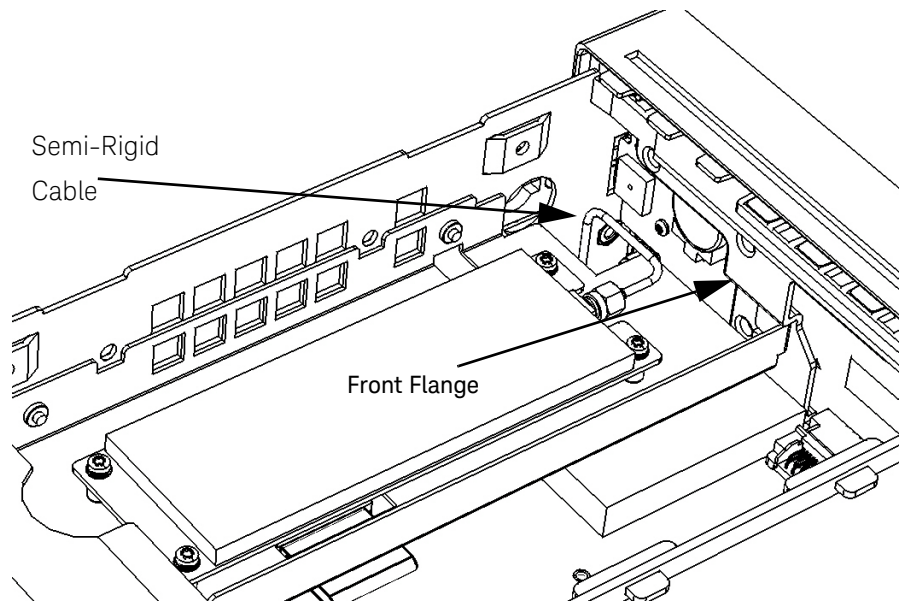

Figure 4-20 Semi-rigid cable position

14 Re-install the front panel as follows:

NOTE

Carefully guide the semi-rigid cable into the chassis while installing the front panel onto the motherboard.

15 Line up the edge connector pins on the motherboard with the edge connector on the front panel and carefully press the front panel onto the motherboard.

NOTE

The four standoffs on the aluminum side panels (two on each side) must lock into the four holes cut out on the sides of the front panel (two on each side).

NOTE

Be sure that the right-hand side tab (see step 8 above) locks the right-hand side panel in place. It may be necessary to gently press outward on the right-hand side panel until the tab locks into place.

- 16** Re-install the T20 TORX screw removed in step 6 above to lock the left-hand side panel to the motherboard.
- 17** Re-install the processor board on the underside of the motherboard (removed in steps 3 and 4 above) as follows:
- 18** Insert the rear left-hand corner of the processor board in the horizontal slot (as viewed from above) and then line up the edge connector pins on the board with the edge connector on the underside of the front panel.

NOTE

Verify that the processor board is parallel horizontally with the motherboard. The rear left-hand corner must sit on top of the small standoff inside the slot.

- 19** Press in carefully on the rear edge of the processor board until the edge connector tabs lock into place.
- 20** Install the T10 TORX screw through the hole in the processor board into the standoff on the motherboard (screw removed in step 2 above).
- 21** Turn the chassis upright. Install the Channel 3 assembly as follows:
- 22** Remove the T20 TORX screw at the rear of the motherboard.
- 23** Connect one end of the supplied 40-pin ribbon cable to J900 on the motherboard. Connect the other end to J401 on the underside of the Channel 3 circuit board.
- 24** Set the Channel 3 assembly down on top of the motherboard so that the female SMA edge connector is near the male SMA connector of the semi-rigid cable installed on the front panel assembly.
- 25** Line up the male semi-rigid SMA cable connector and the Channel 3 assembly female SMA edge connector, connect them together and loosely tighten the SMA connector.

NOTE

Be sure the flange on the front of the Channel 3 assembly is positioned over the tab on the front panel. Refer to [Figure 4-20](#).

- 26** Re-install the T20 TORX screw removed in step 22 above, securing the rear flange on the Channel 3 bracket to the motherboard with the screw. Do not tighten the screw all the way down at this time.

NOTE

If necessary, turn the chassis over and, through the open area provided, loosen the SMA connector on the semi-rigid cable where it connects to the front panel and carefully re-position the cable until it connects the assembly to the front panel, with no stress on the semi-rigid cable.

- 27** Use a 5/16" open-end wrench to secure the two SMA connectors at each end of the semi-rigid cable. Do not overtighten.
- 28** Tighten the T20 TORX screw (step 26 above).
- 29** Install the two supplied flathead screws through the holes in the left-hand aluminum side panel into the embedded nuts on the bracket of the Channel 3 assembly.
- 30** If removed in Preliminary Step 5, re-install the Option 300 Internal Battery Assembly. Be sure to re-connect the cables.
- 31** Re-install the cover by performing the cover removal procedure, in the Preliminary Steps above, in reverse.
- 32** Install the supplied Option 106 or 115 label alongside the front panel Type N connector in the area provided.

To Retrofit the 53220A/53230A Channel 3 Input, 6.0 GHz (Option 106) or 15.0 GHz (Option 115) plus Rear Panel Option 203

Option 203 rear panel channel 3 parts

Item	Keysight part no.	Qty.
Rear panel semi-rigid SMA Cable	53200-61606	1
Front panel plug	53200-40001	1
Retainer	53200-40002	1
Self-tapping screw	0515-5220	1
6.0 GHz PCB assembly (Option 106)	53200-66505	1
15.0 GHz PCB assembly (Option 115)	53200-66506	1
16 GHz shield (Option 115 only)	53200-00606	1
Ribbon cable, 40-pin	53200-61605	1
Labels, 6 GHz	53200-84301	2
Labels, 15 GHz	53200-84302	2
Standoff (Option 115 only)	0380-5091	2
Bracket, aluminum	53200-00603	1
TORX 10 screws	0515-0430	4
Screws, flathead	0515-1946	2
Screw (Option 115 only)	0515-3131	12

NOTE

After the installation of Option 106 or 115, a complete Microwave Frequency Calibration must be performed. Refer to [Chapter 2](#) for the procedure.

Preliminary steps

CAUTION

Before proceeding with the installation, follow all the ESD steps as outlined in the section titled **Do This first** under the **Introduction** at the beginning of Chapter 4 of this service guide.

- 1 Remove the instrument cover as follows:

NOTE

Refer as necessary to the illustrations in the section titled **"To Remove the Cover and Rear Bezel"** on page 185 of this guide.

- 2 To remove the counter handle, rotate the handle to the vertical (90 degree) position and pull outward on the two side arms.
- 3 Using a T20 TORX screwdriver, loosen the two TORX screws securing the rear panel bezel.
- 4 Slide the outside cover of the counter to the rear and remove the cover.
- 5 If installed, disconnect and move the Option 300 Internal Battery DC Power Assembly out of the way as follows (refer to the figures in **Chapter 4, "To Retrofit the Internal Battery DC Power (Option 300)"**, as needed):
 - Remove the two T20 TORX screws and lockwashers holding the Option 300 assembly to the left-hand side panel (as viewed from the rear of the instrument).
 - Lift up carefully on the left side of the assembly and remove the assembly from the three large tabs holding it on the right side.
 - Lay the assembly on its back to the right side of the chassis and place the three small tabs on the back side of the three large tabs into the three slots on the assembly deck. Disconnect the two cables going to the assembly.

6 Assemble the parts in the Option 106/115 package as follows:

NOTE

Refer as necessary to **Figure 4-21**.

- If Option 115 is being installed, insert and tighten the two supplied standoffs (using a 1/4" spintite) in the two **middle** holes closest to the **front** flange of the Channel 2 assembly (Rear Panel Option 203 only).
- Position the printed circuit board over the aluminum bracket so that the SMA edge connector is pointed toward the rear flange (with the hole) and sits on top of the standoffs.
- Install 4 (Option 106) or 6 (Option 115) T10 TORX screws to secure the PC board to the aluminum deck.

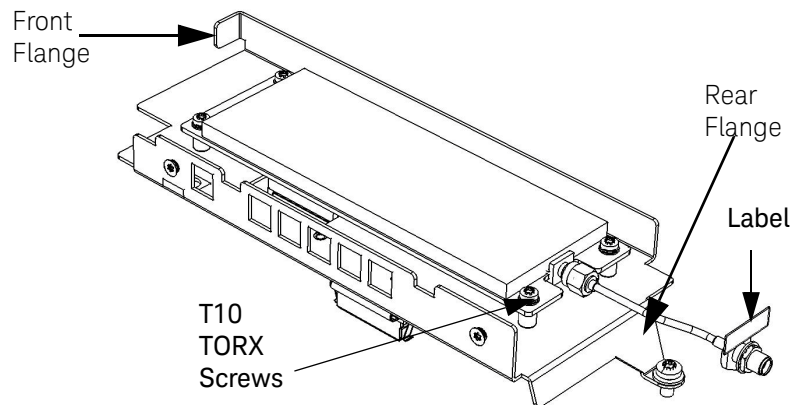

Figure 4-21 53220A/53230A rear panel option 106/203.

Rear panel installation procedure (Option 203 only)

- 1 Install the Channel 3 assembly as follows:
- 2 Remove the T20 TORX screw at the rear of the motherboard.
- 3 Connect one end of the supplied 40-pin ribbon cable to J900 on the motherboard. Connect the other end to J401 on the underside of the Channel 3 circuit board.
- 4 Set the Channel 3 assembly down on top of the motherboard so that the female SMA edge connector is towards the rear panel. The front flange on the right-front of the Channel 3 assembly bracket must rest on the tab protruding from the front panel (see [Figure 4-22](#)).

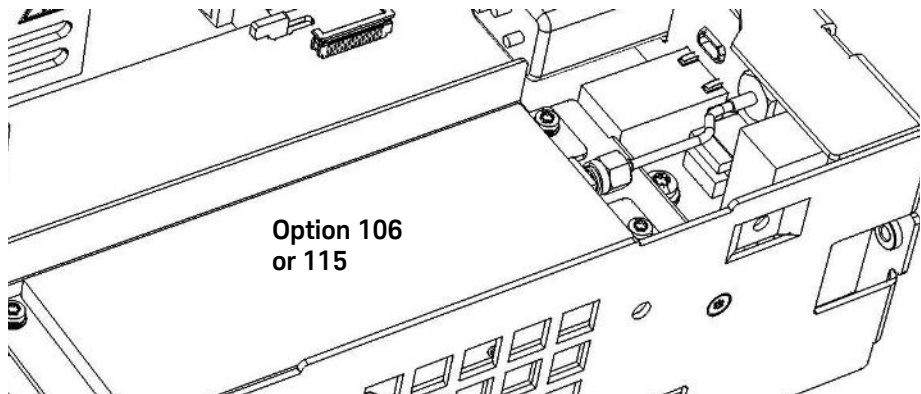

Figure 4-22 Channel 3 assembly installed on top of the motherboard, with the female SMA edge connector pointing toward the rear.

- 5 Install the supplied SMA semi-rigid cable as follows:
- 6 Insert the end of the semi-rigid cable with the female SMA connector through the hole on the rear panel marked "Opt 106/115". Secure the connector with the supplied 5/16" hex nut and lockwasher. Finger-tighten only.
- 7 Line up the male SMA cable connector on the semi-rigid cable and the Channel 3 assembly female SMA edge connector, connect them together and tighten both of the SMA connectors using a 5/16" wrench.

NOTE

If necessary, loosen the hex nut on the other end of the semi-rigid cable to align the cable and then tighten all nuts. There should be no stress on the semi-rigid cable.

- 8** Re-install the T20 TORX screw removed in step 2 above, securing the rear flange on the Channel 3 bracket to the motherboard with the screw.
- 9** Install the two supplied flathead screws through the holes in the left-hand aluminum side panel into the embedded nuts on the aluminum bracket of the Channel 3 assembly.
- 10** If removed previously, re-install the internal battery assembly. Be sure to re-connect the cables.
- 11** Re-install the cover by performing the cover removal procedure (Preliminary Steps 1-4), in reverse.
- 12** Install the supplied Option 106 or 115 label above the rear panel SMA connector in the location provided.

To Retrofit Option 150 (Pulse Microwave Measurements) for the 53230A

NOTE

Retrofitting to Option 150 is an internal firmware upgrade to the 53230A. There are no parts associated with this option. However, this option requires that the 53230A has either Channel 3 Option 106 (6.0 GHz) or Option 115 (15.0 GHz) installed.

Retrofitting procedure

NOTE

Option 150 may be obtained by ordering 53230U-150 from your nearest Keysight Technologies Sales Office. Refer to the list of Sales and Service offices in the Appendix for the sales office nearest to you.

THIS PAGE HAS BEEN INTENTIONALLY LEFT BLANK.

5 Replaceable Parts

Introduction	250
Contacting Keysight Technologies	251
How To Order A Part	252
Replaceable Parts	254

Introduction

This chapter contains information for ordering parts.

Table 5-1 lists all replaceable assemblies and parts for the Keysight 53210A/53220A/53230A Counters.

Figure 5-1 and **Figure 5-2** show the locations of the replaceable assemblies.

This chapter contains the following sections:

- Introduction
- Contacting Keysight Technologies
- How to order a part
- Replaceable parts

Contacting Keysight Technologies

Depending on where you are in the world, there are one or more ways in which you can order parts or obtain parts information from Keysight Technologies.

- Outside the United States, contact your local Keysight Technologies sales office as shown in the preface of this service guide..
- Within the United States, we encourage you to order replacement parts or request parts information directly by telephone or mail from the Keysight Support Materials Organization, using the telephone numbers or address listed below. You can also contact your local Keysight Technologies Sales and Service office as shown in the preface of this guide.

By telephone (in the United States):

- For parts ordering, use our toll-free number, (800) 227-8164, Monday through Friday (except Holidays), 6 a.m. to 5 p.m. (Pacific Time).
 - If you need a part in a hurry, an extra-cost Hotline phone ordering service is available 24 hours a day. Use the toll-free number above at the times indicated; at other times, use (916) 785-8460.
- For parts identification assistance, call us at (916) 783-0804.
 - Our Parts Identification hours are from Monday through Friday, 6 a.m. to 5 p.m. (Pacific Time).

For mail correspondence, use the address below:

- Keysight Technologies
Support Materials Roseville
P.O.Box 1145
Roseville, CA 95661-1145

How To Order A Part

Keysight Technologies wants to keep your parts ordering process as simple and efficient as possible. To order parts perform the following steps:

- 1** Identify the part and the quantity you want.
- 2** Determine the ordering method to be used and contact Keysight Technologies.

Parts Identification

To identify the part(s) you want, first refer to [Figure 5-1](#) and [Figure 5-2](#) at the back of this chapter. Use [Table 5-1](#) to obtain the part number.

When ordering from Keysight Technologies, the important numbers to note from the Parts List are the Keysight Part Number and the quantity of the part you want.

If the part you want is NOT identified in [Table 5-1](#) or [Figure 5-1](#) and [Figure 5-2](#), you can call on Keysight Technologies for help (see “[Contacting Keysight Technologies](#)” on page 251”). Please have the following information at hand when you contact Keysight Technologies for help:

- Counter model number (example, “Keysight 53230A”).
- Part number.
- Description of the part and its use.
- Quantity of the part required.
- Complete instrument serial number (example, “MY50000125”). The serial number for your counter may be found on a label attached to the counter or by turning the instrument on and pressing these keys:

[Help] / (About)

- The following screen is displayed:

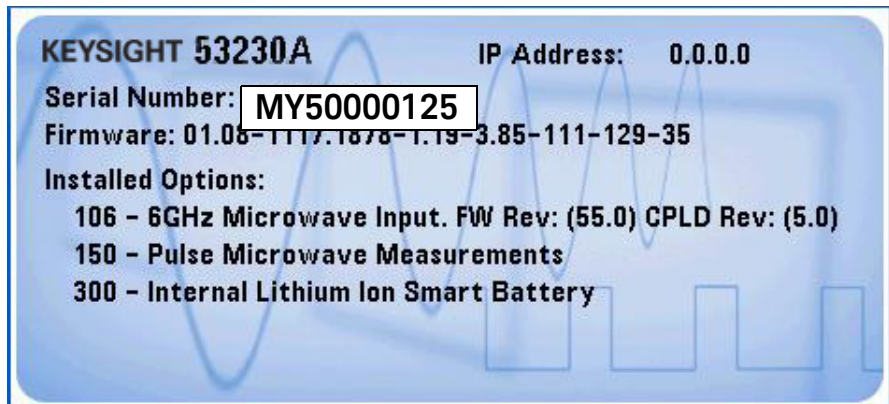

Replaceable Parts

Table 5-1 is a list of replaceable parts and contains the following:

- Electronic assemblies
- Chassis-mounted electrical parts
- Chassis-mounted mechanical parts

The information given for each part consists of the following:

- Counter model number (example, “Keysight 53230A”).
- Keysight Technologies part number.
- Total quantity (QTY) in instrument.
- Description of the part.
- Customer order number.

Table 5-1 Table of replaceable parts

Model number or option number	Keysight part number	Qty	Description	Customer order number
ELECTRONIC ASSEMBLIES				
KEYSIGHT 53210A	53210-66101	1	MOTHERBOARD (STANDARD TIMEBASE)	53210-66101
	53210-66102	1	MOTHERBOARD (HIGH STABILITY TIMEBASE)	53210-66102
KEYSIGHT 53220A	53220-66101	1	MOTHERBOARD (STANDARD TIMEBASE)	53220-66101
	53220-66102	1	MOTHERBOARD (HIGH STABILITY TIMEBASE)	53220-66102
KEYSIGHT 53230A	53230-66101	1	MOTHERBOARD (STANDARD TIMEBASE)	53230-66101
	53230-66102	1	MOTHERBOARD (HIGH STABILITY TIMEBASE)	53230-66102
	P0500-63001	1	PROCESSOR ASSEMBLY	*
	53200-60002	1	FRONT PANEL BOARD	53200-60002

Table 5-1 Table of replaceable parts (continued)

Model number or option number	Keysight part number	Qty	Description	Customer order number
	2090-0977	1	FRONT PANEL DISPLAY	2090-0977
OPTION 106	53200U-106	1	OPTION 106, 6.0 GHz INPUT BOARD	53200U-106 **
OPTION 115	53200U-115	1	OPTION 115, 15.0 GHz INPUT BOARD	53200U-115 **
OPTION 150	53200U-150	1	OPTION 150, MICROWAVE PULSE MEASUREMENTS	53200U-150 **
OPTION 201	53200U-201	1	REAR PANEL PARALLEL INPUTS	53200U-201 **
OPTION 202	53200U-202	1	FRONT PANEL INPUT, TYPE-N, SEMI-RIGID CABLE	53200U-202 **
OPTION 203	53200U-203	1	REAR PANEL SMA SEMI-RIGID CABLE	53200U-203 **
OPTION 300	53200-66507	1	INTERNAL BATTERY PC BOARD (OPTION 300)	P/O 53200-80003
	53200-61602	1	INTERNAL BATTERY Y-CABLE	P/O 53200-80003
	53200-61603	1	INTERNAL BATTERY RIBBON CABLE	P/O 53200-80003
	1420-0909	1	INTERNAL BATTERY	1420-0909
	0950-2496	1	AC POWER SUPPLY / PLASTIC COVER	P/O 53200-80002
	53200U-400	1	GPIO KIT	53200U-400 **
CHASSIS PARTS				
	34401-86020	1	BUMPER KIT	34401-86020
	34401-45021	1	HANDLE	34401-45021
	53200-80005	1	KEYPAD	53200-80005
	53200-87401	1	KNOB	53200-87401
	1990-3728	1	ENCODER	1990-3728
	33220-84101	1	COVER	33220-84101
	1252-8483	1	USB CONNECTOR	1252-8483

Table 5-1 Table of replaceable parts (continued)

Model number or option number	Keysight part number	Qty	Description	Customer order number
	1253-4669	1	LAN CONNECTOR	1253-4669
	53200-61608	1	LINE FILTER	53200-61608
	1250-3569	1 or 2	FRONT PANEL BNCs	1250-3569
	53200-80004	1	OPTIONAL CHANNEL FRONT PANEL CONNECTOR	53200-80004
	1420-0356	1	RTC BATTERY, FRONT PANEL, CR2032	1420-0356
	33250-68501	1	FAN	33250-68501
KEYSIGHT 53210A	53210-80001	1	FRONT PANEL (53210A)	53210-80001
KEYSIGHT 53220A	53220-80001	1	FRONT PANEL (53220A)	53220-80001
KEYSIGHT 53230A	53230-80001	1	FRONT PANEL (53230A)	53230-80001

* Not customer-replaceable. Must return counter to Keysight Technologies for replacement.

** These items are not obtainable through the Keysight Parts Organization. If one of these parts is defective, you may order a replacement part through your Keysight sales office as a retrofit option, using the provided order number. As an alternative, you may send the counter to Keysight for repair.

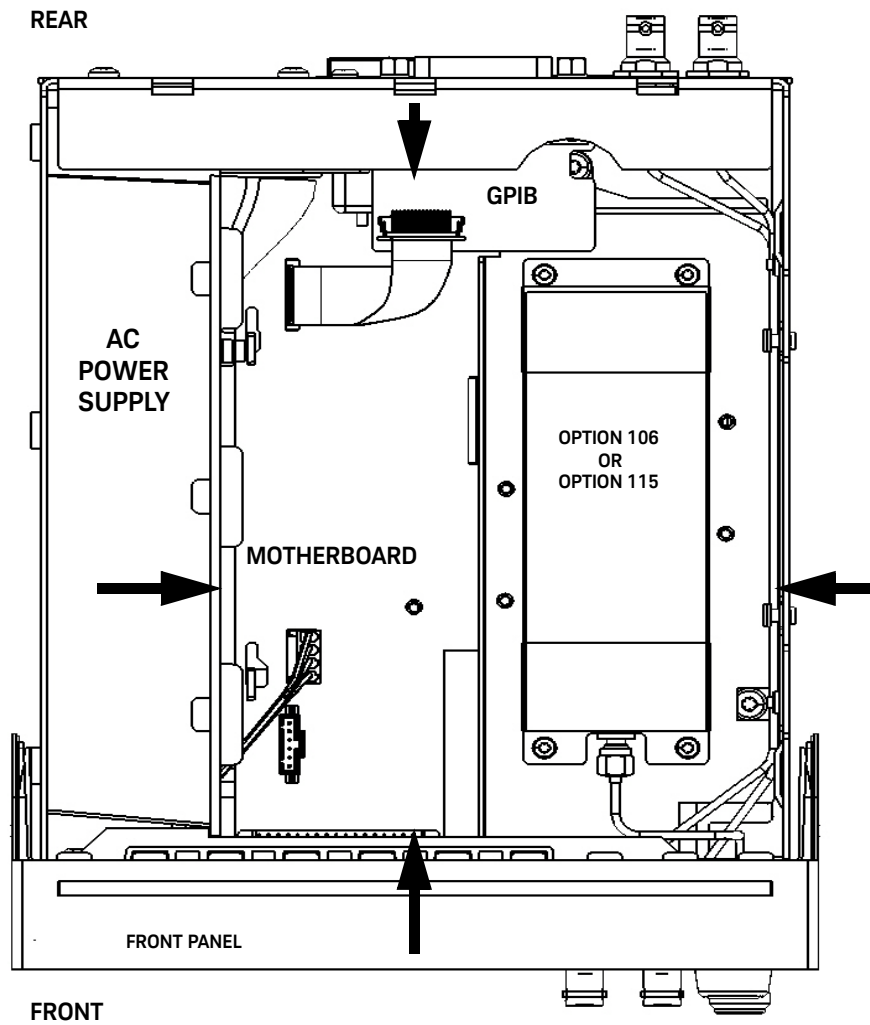

Figure 5-1 Keysight 53210A/53220A/53230A Counters, top view (cover off)

NOTE

If installed, Option 300 Internal DC Battery Assembly (not shown) would cover the area between the arrows.

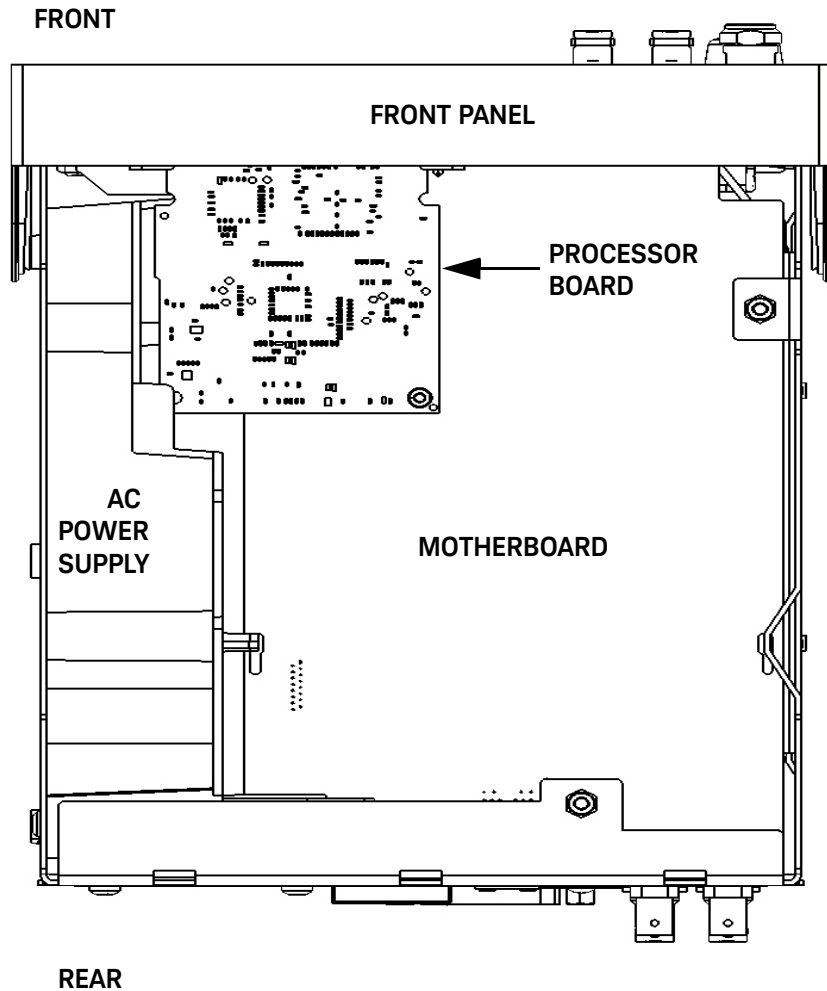

Figure 5-2 Keysight 53210A/53220A/53230A Counters, bottom view (cover off)

6 Backdating

Introduction	260
Backdating Firmware	262
Procedure Changes	264
Backdating Hardware	271
Backdating Specifications	272

Service guide changes.

Introduction

This chapter contains information necessary to adapt this service guide to older instruments.

The backdating information includes the following:

- Backdating Firmware
- Procedure Changes
- Backdating Hardware
- Backdating Specifications

Serial numbers

NOTE

The serial number prefix for your counter is the first 5 character positions in the serial number shown on the counter (for example: MY50000125). The counter serial number suffix (for example: MY50000125) is the production number of the counter. The whole number (MY50000125) is the actual serial number of the counter. See [Figure 6-1](#).

This guide applies directly to counters with the serial prefixes listed in [Table 6-1](#). (See also [Figure 6-1](#).)

Table 6-1 Instruments this guide directly applies to

Instrument	Serial prefix number
Keysight 53210A 350 MHz 10-Digit RF Counter	MY500 or SG500
Keysight 53220A 350 MHz 10-Digit Universal Counter	MY500 or SG500
Keysight 53230A 350 MHz 12-Digit Universal Counter	MY500 or SG500

As engineering changes are made, newer instruments may have higher serial prefix numbers than those listed in [Table 6-1](#). The service guides for these instruments may be supplied on an updated CD-ROM containing the required service information. Use the procedures on the updated CD-ROM that came with your counter. If you have any questions about your Keysight 53210A/53220A/53230A Counter, contact the nearest Keysight Technologies Sales and Support Office as shown in the front of this guide.

Backdating Firmware

Older firmware versions may have known or unknown problems in the code. To see if you have the latest firmware, first determine the firmware version in your counter. Then contact Keysight Technologies to see if you have the latest version. Verify the firmware for your counter as follows:

To determine the counter firmware version

- 1 Press the **Help** key, then the **About** softkey.

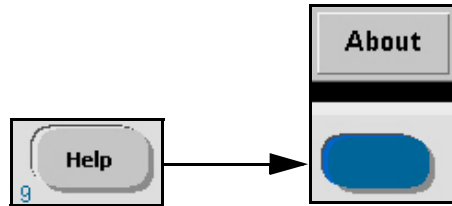

- An information screen (Figure 6-1) is displayed that contains the following items:
 - Keysight model number
 - Instrument serial number
 - IP and GPIB addresses
 - Counter firmware version
(Format: xx.xx - xx.xx - xx.xx - xx.xx)
 - Installed options

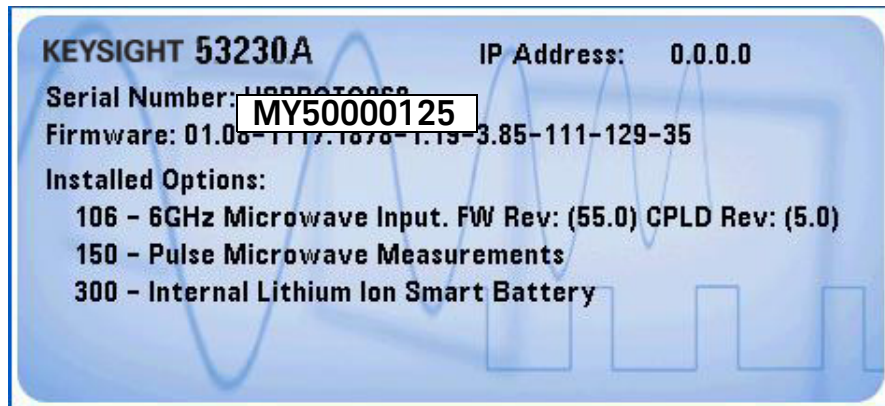

Figure 6-1 Information screen

NOTE

If any number other than 01.07 or 01.08 is displayed as the number before the first dash of the firmware version, then refer to **“Procedure Changes”** on page 264 for information on calibration and/or performance test procedures that apply to your counter.

NOTE

If Option 106 “Microwave Input” is installed in your counter and the “FW Rev” is (27.0), refer to **“Procedure Changes”** on page 264 for information concerning the calibration procedure for your counter.

Procedure Changes

Information concerning Option 106 “Microwave Input”, FW Rev (27.0)

If your counter has Firmware version **01.04 - xx.xx - xx.xx - xx.xx**, or **01.05 - xx.xx - xx.xx - xx.xx**, and you have an Option 106 “Microwave Input” channel with **FW Rev (27.0)** installed, then use the “Microwave Channel Frequency Calibration” procedure shown below for your counter.

Option 106 microwave channel frequency calibration

The following procedure should be performed when Option 106 (6 GHz) with FW Rev (27.0) is installed as Channel 2 in a 53210A or Channel 3 in a 53220A or 53230A. (Refer to “[To determine the counter firmware version](#)” on page 170.)

- 1 First, run the counter self-test as described under [Performing the counter self-test](#) in the [Chapter 2, "Troubleshooting the Counter"](#) section.
A successful self-test procedure verifies that the counter is operational and ready for calibration.
- 2 Unlock the counter by performing the procedure “[To unlock the counter for calibration:](#)” on page 116.
 - Key sequence:
[Utility] / (Cal AutoCal) / enter <code> / (Unlock Cal)
- 3 Set up an external microwave frequency source such as the Keysight E8257D-520 for a 500 MHz sine wave at -27.0 dBm.
- 4 If the source has an ‘output enable’ feature, turn it ON.
- 5 Connect the microwave frequency source to Channel 3 on the counter front panel. (See [Figure 6-2](#).)

NOTE

This will be channel 2 on a 53210A Counter.



Figure 6-2 Microwave source connection to channel 3

6 Press the **Utility** key:



– Display softkey annunciators show:



- 7 Press the **Cal / AutoCal** softkey to display the calibrate options.

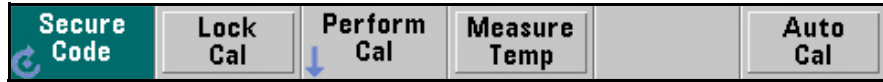

- Display shows:



- **Cal Count** shows the total number of times: (1) a successful calibration step has been completed; (2) calibration data is downloaded; (3) the Cal String or Secure Code is updated; (4) the counter firmware is updated. It is not operator-modifiable and rolls over at $(2^{32} - 1)$. Since the unit is calibrated several times during manufacture, the Cal Count will not be zero when shipped.
 - **Cal String** shows the current calibration string. This string is operator-modifiable, used to record such information as the date of the last calibration, or by whom it was performed. The Calibration String can not be entered from the front panel keys. It can only be entered/updated using the remote SCPI command: **CALibration STRing**. Refer to the Keysight 53210A/53220A/53230A SCPI Programmer's Reference for details of the command format.
 - **Secure Code** displays either all dashes (---) or an operator-entered security code that has not yet been accepted by the counter.
- 8** If “**Unlock Cal**” is displayed on a softkey, the counter is locked against calibration. (See step 2.)
- 9** If “**Lock Cal**” is displayed on a softkey, the counter is unlocked and ready for calibration.
- The **Perform Cal** softkey becomes available.

10 Press the **Perform Cal** softkey:

- Display softkey annunciators show:



11 Press the **Cal Step** softkey.

- Display softkey annunciators show:



* Only displayed if Option 106 or 115 is installed.

12 Press the **uWave** softkey.

- Display softkey annunciators show:

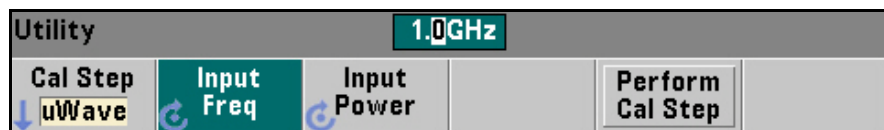

13 Use the front panel knob and left/right arrow keys to enter the value as: 500 MHz in the data entry area to agree with your source.

NOTE

Alternatively, you may use the Shift key on the front panel to put the keyboard keys into a numeric mode, and then enter the entire frequency manually. The data entry area will repeat whatever numbers are used to select the calibration frequency.

14 Press the **Input Power** softkey and enter the power level of the 500 MHz source as -27 dBm. (Must be -27 dBm \pm 0.5 dB at the input connector. If necessary, verify with a power meter.)

- 15** When the input frequency and power are set to agree with your source output, press the **Perform Cal Step** softkey to enter the data into the counter and initiate the microwave oscillator calibration.
- If the calibration step PASSES, after a few seconds the counter momentarily displays:
 - **“Calibration step succeeded.”**
 - The internal calibration constants are updated.
 - The **Cal Count** on the screen will increment.
- 16** Repeat steps 11 to 15 using 1000 MHz and -27.0 dBm. Set the source frequency and power to 1000 MHz and -27.0 dBm.
- If the calibration step PASSES, after a few seconds the counter momentarily displays:
 - **“Calibration step succeeded.”**
 - The internal calibration constants are updated.
 - The **Cal Count** on the screen will increment.
 - If either calibration step FAILS, after a few seconds the counter displays:
 - **“Calibration step failed”**

NOTE

If the calibration fails, the current calibration constants and the Cal Count remain unchanged.

- 17** If the calibration fails (**“Calibration step failed”**), first verify the input frequency and power are correct and the source output is connected and turned on. Then, refer to the troubleshooting procedures starting on [page 160](#) in [Chapter 2](#).
- 18** To check for error messages, refer to the [Summary of Option 106 remote microwave calibration](#): below for information on how to read the error message(s) from a remote computer.

NOTE

If you do not have a remote computer available (requires a LAN, USB or GPIB interface) or are not proficient at programming, contact the nearest Keysight Service Center for information and help on sending the counter to Keysight for repair and/or calibration. See the website information on page 2.

19 If you are able to read the error message(s), consult “[Error Messages](#)” on page 174 for what to do after receiving a specific calibration error message.

Summary of Option 106 microwave calibration procedure:

- **Input signal:** This should be a clean sine wave at each frequency and power level, driving 50 Ω termination.
- **Timebase:** Any external timebase you provide is ignored during calibration.
- Verify signal input connections and source output is **ON**.
- **Procedure:** From the front-panel, the following key strokes initiate the microwave frequency channel calibration:

[Utility] / (Cal AutoCal) / (Perform Cal) / (Cal Step uWave) / enter (Input Freq) <frequency>

[Utility] / (Cal AutoCal) / (Perform Cal) / (Cal Step uWave) / enter (Input Power) <power> / (Perform Cal Step)

Summary of Option 106 remote microwave calibration:

- Set timeout for PC to be greater than 20 seconds.
- Connect calibration source to channel 2 (53210A) or channel 3 (53220A/53230A) at 500 MHz, -27 dBm for Option 106).
- Unlock security: **CALibration:SECurity:STATe OFF, <code>**
- Read security state: **CALibration:SECurity:STATe?**
 - **0** means OFF or unlocked.

- For the 53220A or 53230A Counters, send the command to calibrate as:
"CALibration:LEVe13? 500E8, -27".
- For the 53210A Counter, send the command to calibrate as:
"CALibration:LEVe12? 500E8, -27".
- Retrieve query result:
 - **0** indicates the calibration PASSED.
 - Any value other than **0** indicates calibration FAILED.
- If the calibration passes at 500 MHz, repeat the calibration sequence for 1000 MHz at -27 dBm as follows:
- For the 53220A or 53230A Counters, send the command to calibrate as:
"CALibration:LEVe13? 1E9, -27".
- For the 53210A Counter, send the command to calibrate as:
"CALibration:LEVe12? 1E9, -27".
- Retrieve query result:
 - **0** indicates the calibration PASSED.
 - Any value other than **0** indicates calibration FAILED.
- If non-zero value for either calibration point, read error queue as follows:
SYSTEM:ERROR?
- Read errors until no more errors.
- Consult the **"Error Messages"** on page 174 of **Chapter 2** for what to do after receiving a specific calibration error message.

Backdating Hardware

NOTE

There are no hardware changes to the Keysight 53210A/53220/53230A Counters at this time.

Backdating Specifications

NOTE

There are no specification changes to the Keysight 53210A/53220/53230A Counters at this time.



This information is subject to change without notice. Always refer to the Keysight website for the latest revision.

© Keysight Technologies 2011–2018
Edition 8, March 2018

Printed in Malaysia



53220-90010

www.keysight.com