

**U8793**

**HIOKI**

**MR8790**

Instruction Manual

**MR8791**

**ARBITRARY WAVEFORM  
GENERATOR UNIT**

**WAVEFORM  
GENERATOR UNIT**

**PULSE GENERATOR UNIT**

**EN**

July 2018 Revised edition 2  
U8793A981-02 18-07H





# Contents

Introduction.....	1		
Verifying Package Contents .....	2		
Safety Information .....	2		
Operating Precautions .....	5		
<b>1 Overview</b> .....	<b>7</b>		
1.1 Features .....	7		
1.2 Part Names and Functions .....	8		
1.3 Inspecting the Unit before Use .....	9		
<b>2 Connecting the Unit</b> .....	<b>11</b>		
2.1 Installing the Unit in and Removing the Unit from a Memory HiCorder .....	11		
■ Installing the unit.....	11		
■ Removing the unit.....	11		
2.2 Connecting Cables to the Output Terminals.....	12		
2.3 Output Terminals.....	13		
2.4 Connecting Wires to the External Control Terminals (U8793) .....	14		
<b>3 Signal Generation Settings Screen (Generator Screen)</b> .....	<b>15</b>		
■ Method for copying and pasting channel settings .....	16		
<b>4 FG Waveform Settings (U8793, MR8790)</b> .....	<b>17</b>		
■ Method for setting values.....	18		
4.1 Setting the Waveform Type .....	20		
4.2 Setting the Frequency .....	21		
4.3 Setting the Amplitude .....	22		
4.4 Setting the Offset .....	23		
4.5 Setting the Duty (Pulse Wave Output Only) .....	24		
4.6 Setting the Phase .....	25		
4.7 Setting the Output to ON or OFF ..	26		
4.8 Setting Behavior When Output is OFF .....	27		
<b>5 Setting Pulse and Pattern Output (MR8791)</b> .....	<b>29</b>		
5.1 Setting the Mode .....	29		
5.2 Setting the Pulse Mode.....	30		
■ Setting the frequency.....	30		
■ Setting the duty.....	31		
■ Setting the output type.....	32		
■ Setting output.....	33		
5.3 Setting the Pattern Mode .....	34		
■ Setting the output type.....	34		
■ Setting the pattern to use.....	35		
■ Method for registering a pattern.....	36		
■ Setting the clock frequency.....	38		
■ Setting output.....	39		
<b>6 Sweep Setting (U8793)</b> .....	<b>41</b>		
6.1 Selecting the Sweep Type .....	41		
6.2 Setting the Start Value .....	42		
6.3 Setting the End Value .....	43		
6.4 Setting the Sweep Time .....	44		
<b>7 Arbitrary Waveform Settings (U8793)</b> .....	<b>45</b>		
7.1 Setting the Waveform Type .....	45		
7.2 Registering a Waveform .....	46		
■ Registering data measured with a Memory HiCorder .....	47		
■ Registering data created with the SF8000 Waveform Maker.....	49		
7.3 Setting the Clock Frequency.....	51		
7.4 Setting Amplitude Adjustment.....	52		
7.5 Setting the Offset .....	53		
7.6 Setting the Delay .....	54		
7.7 Setting the Number of Loops (When Sweep Is Disabled).....	55		
7.8 Setting the Filter.....	56		
7.9 Setting the Output to ON or OFF ..	57		
7.10 Setting Behavior When Output is OFF .....	58		
<b>8 Program Settings (U8793)</b> .....	<b>59</b>		
8.1 Switching to the Program Settings Screen .....	59		
8.2 Editing the Program.....	60		
■ Opening the Edit screen .....	60		

- Configuring each step.....61
  - Ending program editing.....63
- 8.3 Setting the Overall Number of Loops ..... 65**
- 8.4 Setting the Filter..... 66**
- 8.5 Saving the Edited Program ..... 67**
- 8.6 Checking Program Progress..... 68**
- 9 Outputting Signals ..... 69**
- 9.1 Setting the Control Method ..... 69**
- 9.2 Setting Output When Measurement Completes..... 70**
- 9.3 Controlling Signal Output ..... 71**
- 10 Configuring Settings on the Waveform Screen ..... 73**
- 10.1 Setting Output Waveform Parameters..... 73**
  - To display the waveform and output parameter settings in separate windows ....74
- 10.2 Waveform Type and Output Status Display ..... 76**
- 11 Self-test Function ..... 77**
- 11.1 Monitoring Output Values with Test Output ..... 77**
- 12 External Output Terminal (U8793) ..... 81**
- 12.1 External Input ..... 82**
- 12.2 External Output ..... 83**
- 13 Waveform Maker ..... 85**
- 13.1 Overview of the SF8000 Waveform Maker..... 85**
  - Operating environment .....85
  - Functional specifications.....85
- 13.2 Installing the SF8000 Application . 87**
- 13.3 Launching and Exiting the SF8000 Application ..... 89**
  - Launching the application .....89
  - Exiting the application.....90
- 13.4 Uninstalling the SF8000 Application..... 91**
- 13.5 SF8000 Screen..... 92**
  - Setting the display format .....93

- Setting the time axis range .....94
  - Input mode screens .....94
- 13.6 Arbitrary Waveform Input Mode.... 96**
  - Basic instructions.....96
  - Editing mode.....97
  - Waveform creation.....98
  - Properties .....100
  - Calculations using previously input waveforms .....101
- 13.7 Function Input Mode ..... 102**
  - Basic instructions.....102
  - Example of program creation.....102
  - Expressions and operations .....103
  - Control words.....104
  - Functions .....106
  - Usable characters.....109
- 13.8 Step Input Mode .....110**
  - Basic instructions.....110
  - Example of waveform creation .....110
  - Start and end point settings .....110
  - Waveform type and settings .....110
  - Editing steps .....111
  - Reordering the display.....111
- 13.9 Interpolation Input Mode .....112**
  - Basic instructions.....112
  - Editing mode.....114
  - Dot data list.....114
  - Interpolation method .....116
- 13.10 Pulse Pattern Mode .....117**
  - Basic instructions.....117
  - Example of waveform creation .....118
- 13.11 Transferring Data .....119**
- 13.12 Saving and Loading Data ..... 120**
  - Saving and loading all data.....120
  - Saving and loading data for an individual input mode (import, export).....121

**14 Specifications ..... 123**

- 14.1 U8793 Arbitrary Waveform Generator Unit ..... 123**
  - General specifications .....123
  - Output specifications .....123
  - Sweep function specifications.....125
  - Program functional specifications .....125
  - Other specifications .....125
- 14.2 MR8790 Waveform Generator Unit ..... 126**
  - General specifications .....126
  - Voltage output specifications .....127
- 14.3 MR8791 Pulse Generator Unit..... 128**
  - General specifications .....128
  - Pulse output specifications .....129
  - Pattern output specifications.....129
  - Output connector specifications.....129

<b>15</b>	<b>Maintenance and Service</b>	<b>131</b>
15.1	Cleaning the Unit.....	131
15.2	Troubleshooting .....	132
15.3	Error Messages .....	133
<b>Index</b>		<b>Ind.1</b>

11

12

13

14

15

9

10

Ind.



# Introduction

Thank you for purchasing the Hioki U8793 Arbitrary Waveform Generator Unit, MR8790 Waveform Generator Unit and MR8791 Pulse Generator Unit. To obtain maximum performance from the unit, please read this manual first, and keep it handy for future reference.

## Trademarks

Microsoft, Windows and Excel are either registered trademarks or trademarks of Microsoft Corporation in the United States and other countries.

## Verifying Package Contents

When you receive the unit, inspect it carefully to ensure that no damage occurred during shipping. In particular, check the connectors. If damage is evident, or if it fails to operate according to the specifications, contact your authorized Hioki distributor or reseller. Store the packaging in which the unit was delivered, as you will need it when transporting the unit.

## Safety Information

This unit is designed to conform to IEC 61010 Safety Standards, and has been thoroughly tested for safety prior to shipment. However, using the unit in a way not described in this manual may negate the provided safety features.

Before using the unit, be certain to carefully read the following safety notes.

### **DANGER**



**Mishandling during use could result in injury or death, as well as damage to the unit. Be certain that you understand the instructions and precautions in the manual before use.**







### **WARNING**







**With regard to the electricity supply, there are risks of electric shock, heat generation, fire, and arc discharge due to short circuits. If persons unfamiliar with electrical measuring instrument are to use the instrument, another person familiar with such instruments must supervise operations.**

## Notations

In this manual, the risk seriousness and the hazard levels are classified as follows.

 <b>DANGER</b>	Indicates an imminently hazardous situation that will result in death or serious injury to the operator.
 <b>WARNING</b>	Indicates a potentially hazardous situation that may result in death or serious injury to the operator.
 <b>CAUTION</b>	Indicates a potentially hazardous situation that may result in minor or moderate injury to the operator or damage to the unit or malfunction.
<b>IMPORTANT</b>	Indicates information related to the operation of the unit or maintenance tasks with which the operators must be fully familiar.
	Indicates a high voltage hazard. If a particular safety check is not performed or the unit is mishandled, this may give rise to a hazardous situation; the operator may receive an electric shock, may get burnt or may even be fatally injured.
	Indicates a prohibited action.
	Indicates the action which must be performed.
(p. )	Indicates the location of reference information.
<b>CURSOR</b> (bold)	Bold alphanumeric characters in this text show characters appeared on the operation keys.
[ ]	Menus, commands, dialogs, buttons in a dialog, and other names on the screen are indicated in <b>brackets</b> .
*	Additional information is presented below.

## Symbols on the unit

	Indicates cautions and hazards. When the symbol is printed on the unit, refer to a corresponding topic in the Instruction Manual.
	Indicates a fuse.
	Indicates a grounding terminal.
	Indicates DC (Direct Current).
	Indicates AC (Alternating Current).

## Symbols for standards

	Indicates that the product conforms to regulations set out by the EC Directive.
---	---

## Accuracy

We define output tolerances in terms of setting values, with the following meanings:

Setting	Indicates the value set as the output voltage, current, or other quantity.
---------	--

## Measurement categories

To ensure safe operation of measuring instruments, IEC 61010 establishes safety standards for various electrical environments, categorized as CAT II to CAT IV, and called measurement categories.

### ⚠ DANGER



- Using a measuring instrument in an environment designated with a higher-numbered category than that for which the instrument is rated could result in a severe accident, and must be carefully avoided.
- Using a measuring instrument without categories in an environment designated with the CAT II to CAT IV category could result in a severe accident, and must be carefully avoided.

- CAT II: When directly measuring the electrical outlet receptacles of the primary electrical circuits in equipment connected to an AC electrical outlet by a power cord (portable tools, household appliances, etc.).
- CAT III: When measuring the primary electrical circuits of heavy equipment (fixed installations) connected directly to the distribution panel, and feeders from the distribution panel to outlets.
- CAT IV: When measuring the circuit from the service drop to the service entrance, and to the power meter and primary overcurrent protection device (distribution panel).

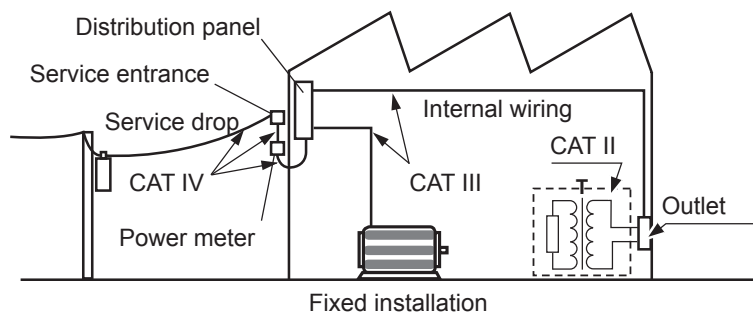

# Operating Precautions

## Check before use

Follow these precautions to ensure safe operation and to obtain the full benefits of the various functions.

### **DANGER**

If the connecting cable or the unit is damaged, there is a risk of electric shock. Before using the unit perform the following inspection.



- Before using the unit, make sure that the insulation on the cables are undamaged and that no bare conductors are improperly exposed. If there is any damage on the cable, replace it with those specified by our company.
- Before using the unit for the first time, verify that it operates normally to ensure that no damage occurred during storage or shipping. If you find any damage, contact your authorized Hioki distributor or reseller.

## Unit installation

### **WARNING**

Installing the unit in inappropriate locations may cause a malfunction of unit or may give rise to an accident. Avoid the following locations.



- Exposed to direct sunlight or high temperature
- Exposed to corrosive or combustible gases
- Exposed to a strong electromagnetic field or electrostatic charge
- Near induction heating systems (such as high-frequency induction heating systems and IH cooking equipment)
- Susceptible to vibration
- Exposed to water, oil, chemicals, or solvents
- Exposed to high humidity or condensation
- Exposed to high quantities of dust particles

## Handling of the unit

### **DANGER**



- Do not exceed the unit or cable ratings or specifications range.
- To avoid electric shock, do not remove the unit's case.  
The internal components of the unit carry high voltages and may become very hot during operation.

### **WARNING**



- To avoid electric shock accident, before removing or replacing the unit, confirm that the Memory HiCorder is turned off and that the connection cables are disconnected.
- To avoid the danger of electric shock, never operate the MEMORY HiCORDER with the unit removed. Install a blank panel in the Memory HiCorder after removing the unit.
- To avoid damage to the unit or electric shock accident, use original screws from the factory shipment for fastening the unit.  
If any of the screws is lost or there is any damage on the unit, contact your authorized Hioki distributor or reseller.

### **CAUTION**



- To avoid damage to the unit, do not touch the connectors to be inserted into the Memory HiCorder.
- Do not perform measurements when the blank panel of the Memory HiCorder has been removed. This condition will cause unstable temperature in the unit and does not satisfy the specifications.



- To avoid damage to the unit, protect it from physical shock when transporting and handling. Be especially careful to avoid physical shock from dropping.
- The mounting screws must be firmly tightened or the unit may not perform to specifications, or may even fail.

This unit may cause interference if used in residential areas. Such use must be avoided unless the user takes special measures to reduce electromagnetic emissions to prevent interference to the reception of radio and television broadcasts.

## Precautions during transportation

Store the packaging in which the unit was delivered, as you will need it when transporting the unit.

## 1.1 Features

The U8793, MR8790, and MR8791 are Memory HiCorder units designed to output basic waveforms such as sine waves and rectangular waves, user-created waveforms, logic patterns, and other signals. (Models vary by the type of waveform they can output.) Since a single Memory HiCorder can accommodate the U8793, MR8790, or MR8791 along with one or more measurement units, it is possible to both measure and generate waveforms with one instrument.

### U8793 Arbitrary Waveform Generator Unit

#### Isolated-channel output

Each unit provides two channels of output. Since output channels are isolated from the host Memory HiCorder's chassis as well as from each other, the instrument can be connected to other devices that operate at a different potential. (The maximum rated terminal-to-ground voltage is limited to 33 V AC RMS or 70 V DC.)

#### Maximum output voltage of 15 V

The unit can output up to 15 V. This capability eliminates the need to connect the unit's output to an external amplifier prior to simulating a signal from an automotive sensor or other device, enabling output signals to be applied directly.

#### Channel synchronization

Phase can be set between channels on the same unit and between channels on different units.

#### Sweep functionality

Sweep functionality is provided for frequency, amplitude, offset, and duty (pulse waves only) for FG waveforms and arbitrary waveforms.

#### Program function

Up to 128 steps can be combined to create output sequences. Users can set an output waveform (FG waveform, sweep waveform, or arbitrary waveform) and a loop count for each step.

#### Observed waveform output

The unit can load waveform data measured by the Memory HiCorder and then output a waveform that is identical to the observed waveform, enabling use in applications such as reproduction testing.

### MR8790 Waveform Generator Unit

#### Isolated-channel output

Each unit provides four channels of output. Since output channels are isolated from the host Memory HiCorder's chassis as well as from each other, the instrument can be connected to other devices that operate at a different potential. (The maximum rated terminal-to-ground voltage is limited to 33 V AC RMS or 70 V DC.)

#### High-precision DC output

Thanks to its ability to generate high-precision DC output with an output accuracy of  $\pm 0.6$  mV, the MR8790 can generate output simulating the minuscule voltage variations of sensor output.

### MR8791 Pulse Generator Unit

#### Multichannel output

Each unit provides eight channels of output. Output channels are isolated from the host Memory HiCorder's chassis. (Output channels are not isolated from each other.) (The maximum rated terminal-to-ground voltage is limited to 33 V AC RMS or 70 V DC.)

#### Wide selection of output modes

Depending on the configuration, each channel can generate independent pulse output, or all channels can generate synchronized pattern output. In addition, users can select either TTL level logic output or open-collector output as the output type (for each channel).

# 1.2 Part Names and Functions

## Front (U8793)

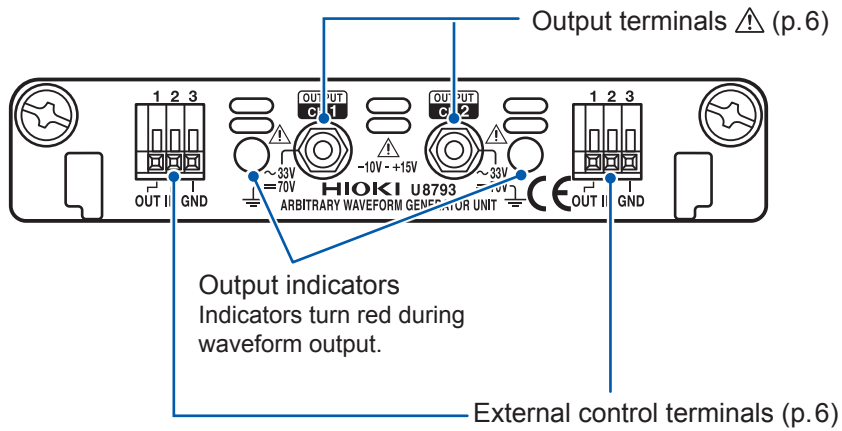

## Front (MR8790)

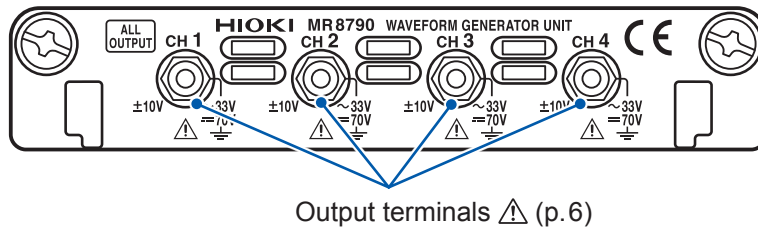

## Front (MR8791)

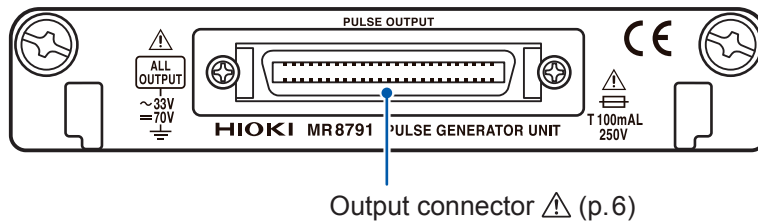

## 1.3 Inspecting the Unit before Use

Before using the unit, inspect it to ensure that it did not sustain any damage during storage or transport and that it is operating properly. If you discover any damage, contact your authorized Hioki distributor or reseller.

### (1) Inspecting connection cables

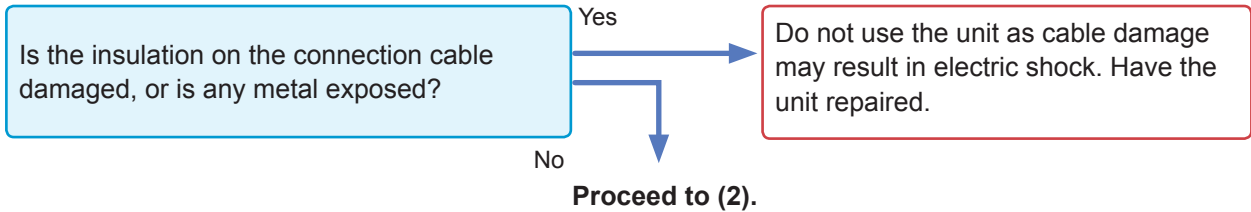

### (2) Inspecting the unit

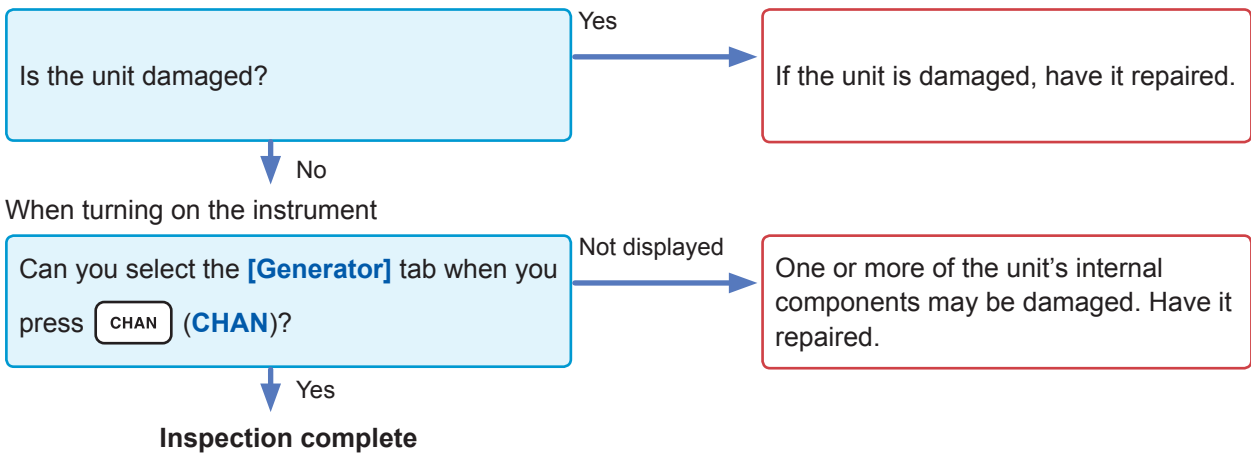



# 2

# Connecting the Unit

## 2.1 Installing the Unit in and Removing the Unit from a Memory HiCorder

For more information about how to install the unit, see the Memory HiCorder's instruction manual.

You will need: Phillips head screwdriver (No. 2)

# 2

### Installing the unit

Example: U8793

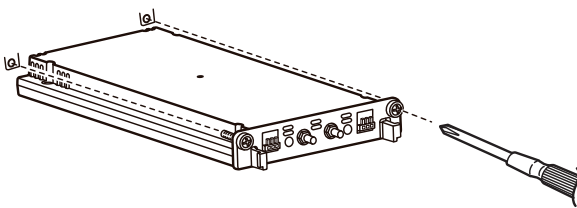

- 1 Turn off the Memory HiCorder into which you will install the unit.
- 2 Exercising care to orient the unit properly, insert it firmly as far as it will go.  
Orient the unit so that the lettering on its front faces the same direction as the lettering on the host Memory HiCorder.
- 3 Securely tighten the fastening screws on the unit with the Phillips head screwdriver.

### Removing the unit

Example: U8793

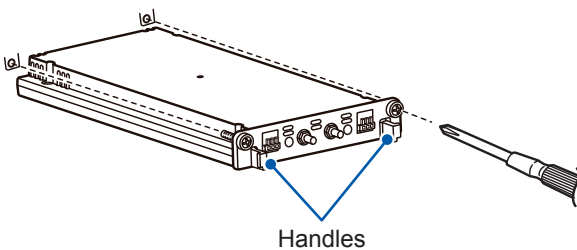

- 1 Turn off the Memory HiCorder from which you will remove the unit.
- 2 Disconnect all connection cables, thermocouples, and other devices that are connected to the unit.
- 3 Loosen the fastening screws on the unit with the Phillips head screwdriver.
- 4 Gripping the handles, pull the unit towards you.
- 5 Attach the blank panel to cover the opening on the Memory HiCorder from which you removed the unit.

## 2.2 Connecting Cables to the Output Terminals

Be sure to use only Hioki-specified connection cables with the unit. Use of other cables may prevent the unit from generating waveforms accurately due to poor contact or other issues.

### U8793 and MR8790

You will need: L9795-01 Connection Cable or L9795-02 Connection Cable

Example: U8793

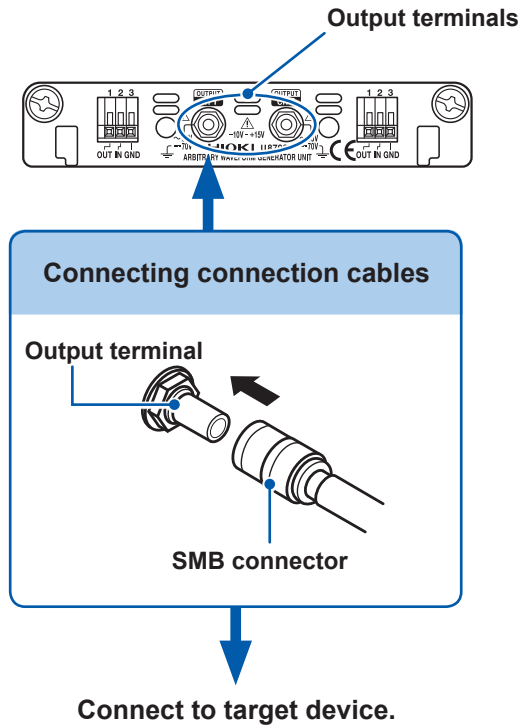

- 1 Insert the connection cable's SMB connector into the unit's output terminal until you hear it click into place.
- 2 Connect the target device to the clip side of the connection cable.

### Disconnecting cables from the output terminals

Grip the cable by the SMB connector (not the cable itself) and pull toward you to disconnect the cable.

**MR8791**

You will need: Connection cable

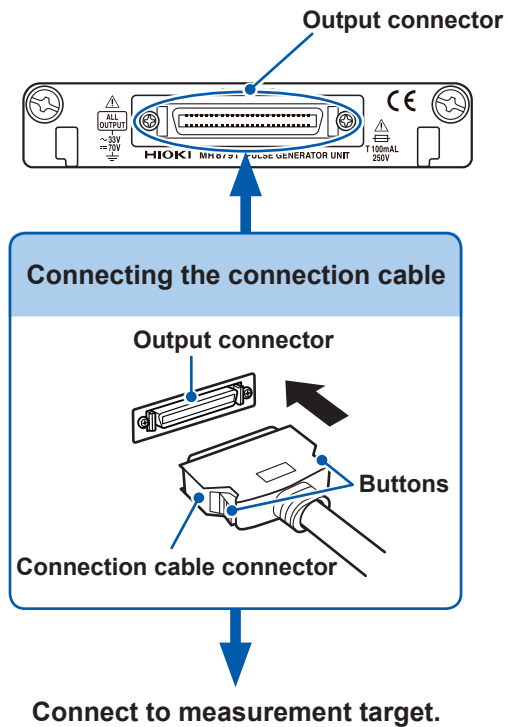

- 1** Connect the connection cable's connector to the unit's output connector.
- 2** Connect the connection cable to the device being measured.

**To disconnect the cable from the output terminal**

Pull the connection cable's connector toward you while depressing the buttons on the connector to disconnect the cable.

**2**

Connecting the Unit

## 2.3 Output Terminals

### ⚠ WARNING



The allowable load resistance for the unit's analog output terminals is 1.5 k $\Omega$  or greater (U8793) or 2 k $\Omega$  or greater (MR8790). Do not connect a load whose resistance is less than the allowable load resistance or short the unit's outputs. Doing so may damage the unit or cause a fire.

### ⚠ CAUTION



Do not apply a voltage from outside the device to the analog output terminals. Doing so may damage the unit.

## 2.4 Connecting Wires to the External Control Terminals (U8793)

The following describes how to connect wires to the unit's external control terminals.

### Procedure

#### You will need

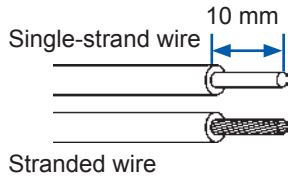

Compatible wires: Single-strand wire  $\phi 0.65$  mm (22 AWG)  
Twisted wire  $0.32$  mm<sup>2</sup> (22 AWG)

Usable wire: Single-strand wire  $\phi 0.32$  to  $\phi 0.65$  mm (28 to 22 AWG)  
Stranded wire  $0.08$  to  $0.32$  mm<sup>2</sup> (28 to 22 AWG)  
Strand diameter  $\phi 0.12$  mm (per strand)

Standard stripped wire length: 9 to 10 mm

Tool for manipulating terminal buttons: Flat-head screwdriver (with a shaft diameter of  $\phi 3$  mm and a tip width of 2.6 mm)

#### Connection method

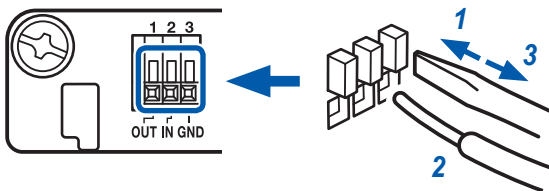

- 1** Depress the terminal button with a flathead screwdriver or other tool.
- 2** Insert the wire into the wire connection hole while continuing to depress the button.
- 3** Release the button.  
The wire will be locked in place.

Terminal no.	Operation
1	OUT: Outputs a LOW-level signal during waveform output.
2	IN: When using the program function, inputting a LOW-level signal from an external device will cause the unit to cancel the hold state and transition to the next step.
3	GND terminal (same potential as the Memory HiCorder's GND)

# 3

## Signal Generation Settings Screen (Generator Screen)

Switch to the Generator screen (signal generation settings screen) and set the output channel.

When the unit is installed in a Memory HiCorder, the instrument will display the Generator screen.

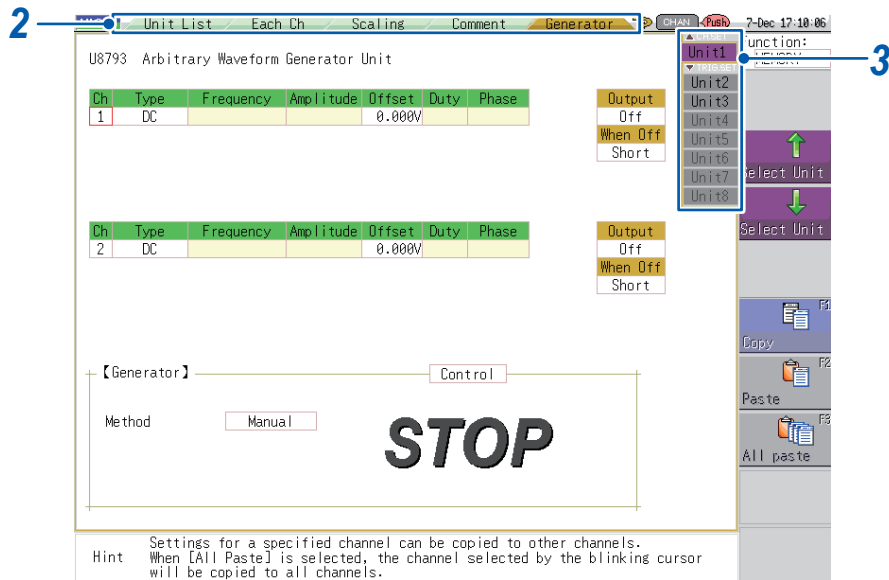

- 1 Press **CHAN** (**CHAN**).
- 2 Select the **[Generator]** tab.
- 3 Press **CH.SET** (**CH.SET**) or **TRIG.SET** (**TRIG.SET**) and select the unit.

# 3

## Method for copying and pasting channel settings

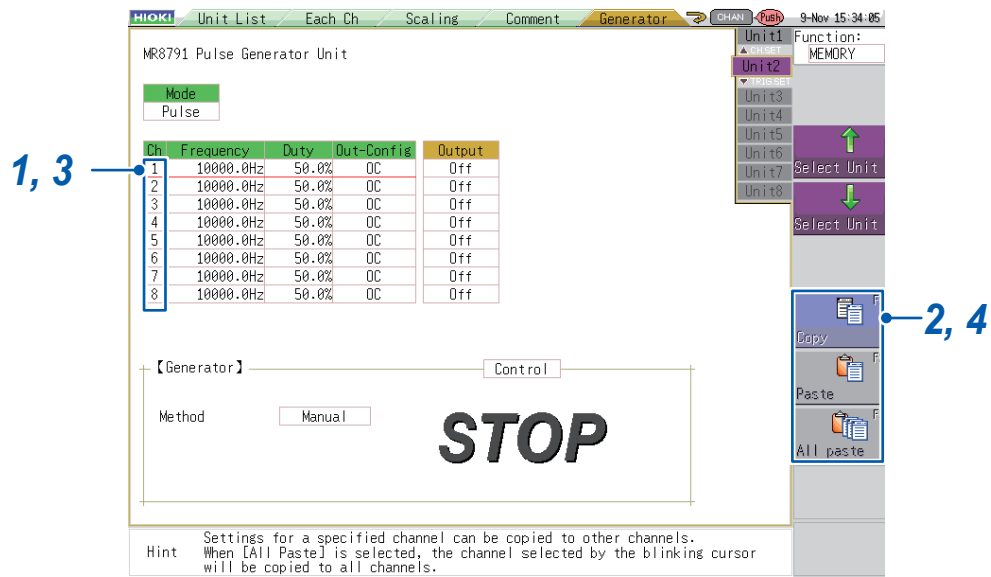

- 1 Select the source channel's [Ch] setting.
- 2 Press a function key (F1 to F5) or select [Copy] with the mouse.
- 3 Move the cursor to the [Ch] setting to which you wish to paste the settings.
- 4 Press a function key (F1 to F5) or select a button with the mouse.

Copy	Copies the settings.
------	----------------------

Paste	Pastes the copied settings.
Paste All	Pastes the settings to all channels.

## 4

# FG Waveform Settings (U8793, MR8790)

This section describes the settings that are available when a U8793 Arbitrary Waveform Generator Unit or an MR8790 Waveform Generator Unit is selected on the Generator screen (signal generation settings screen) (p. 15).

The following parameters can be set for FG waveforms:

Type	Selects the type of waveform.	p.20
Frequency	Sets the frequency.	p.21
Amplitude	Sets the amplitude.	p.22
Offset	Sets the offset.	p.23
Duty (U8793 only)	Sets the duty.	p.24
Phase (U8793 only)	Sets the phase.	p.25
When Off	Sets the output terminal state to use when waveform output is stopped.	p.26
Output	Turns output on or off.	p.27
<b>(When the sweep setting is enabled)</b>		
Sweep Time	Sets the sweep time.	p.44



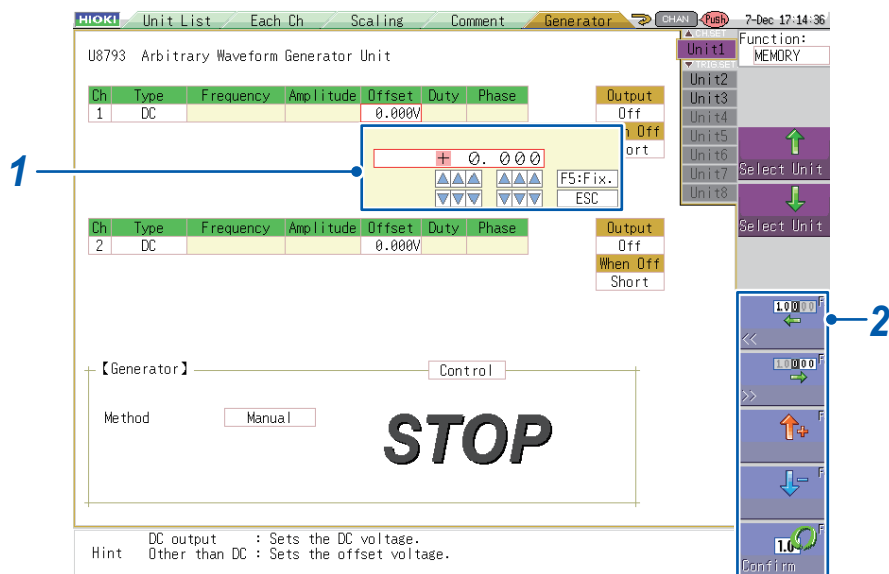

## Method for setting values

Parameters that are set as values can be entered using either the **[Up-Down]** (arrow key input) method or the **[Tenkey entry]** (numeric input) method.

### After selecting the [Up-Down] method

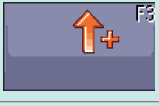
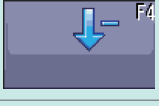

- 1 A window will be displayed.
- 2 Press a function key (**F1** to **F5**) or select a button with the mouse.

	Moves one digit to the left.
	Moves one digit to the right.
	Increases the value.
	Decreases the value.
	Accepts the value.

After selecting [Tenkey entry]

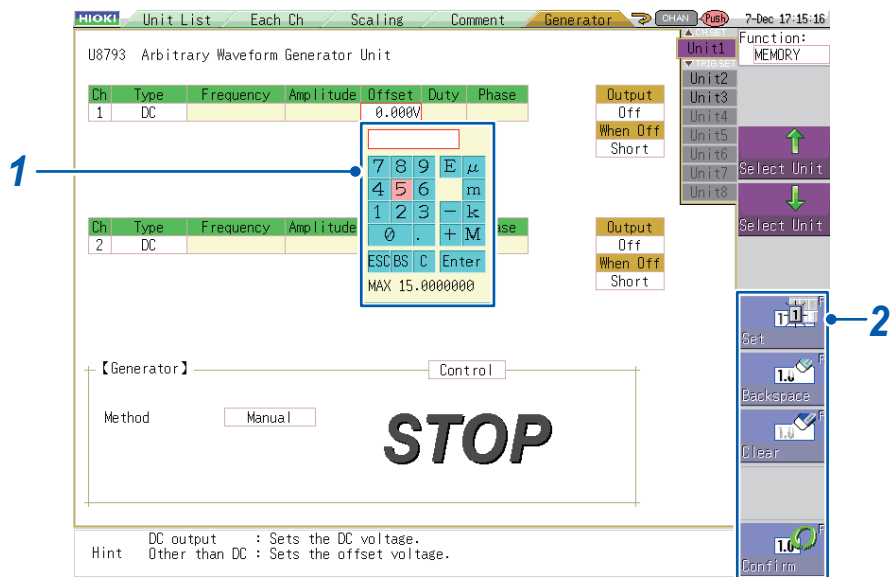

- 1 A window will be displayed.
- 2 Press a function key (F1 to F5) or select a button with the mouse.

Set	Enters the selected value, unit, etc.
Backspace	Deletes the most recently entered value, unit, etc.
Clear	Deletes all entered values.
Confirm	Accepts the value.

## 4.1 Setting the Waveform Type

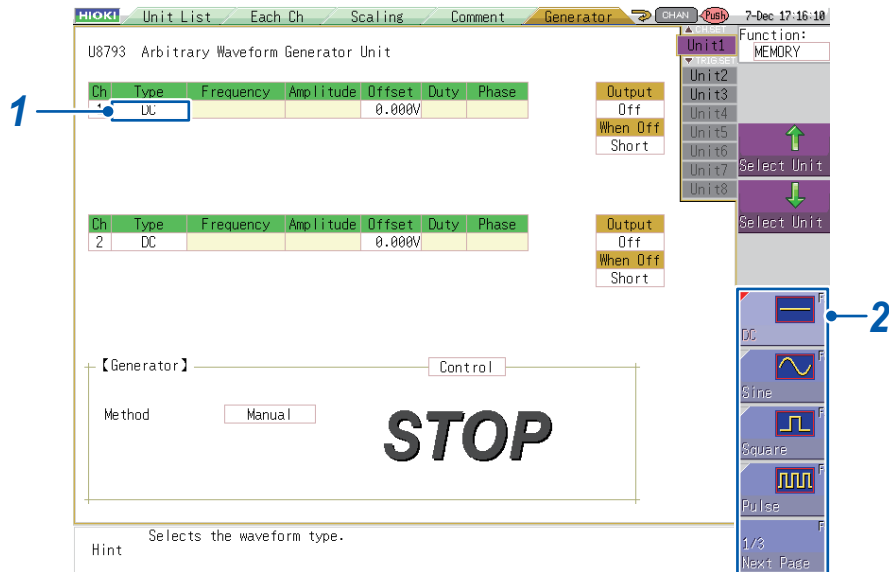

- 1 Select the [Type] setting.
- 2 Press a function key (F1 to F5) or select a button with the mouse.

DC	Outputs a DC waveform.
Sine	Outputs a sine wave.
Square	Outputs a rectangular wave with a fixed duty of 50% (U8793 only).
Pulse	Outputs a pulse wave with variable duty (U8793 only).
Triangle	Outputs a triangular wave (U8793 only).
Ramp-up	Outputs a ramp-up wave (U8793 only).
Ramp-down	Outputs a ramp-down wave (U8793 only).
Arbitrary	Outputs a user-created waveform (U8793 only). (p.45)
Program	Outputs a waveform in accordance with the edited program (U8793 only). (p.59)

### Examples of FG waveforms that can be output



DC

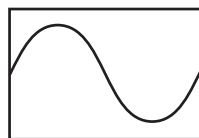

Sine wave

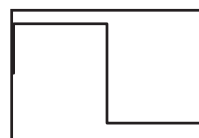

Square wave

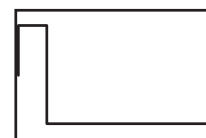

Pulse wave

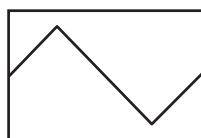

Triangular wave

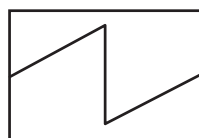

Ramp-up wave

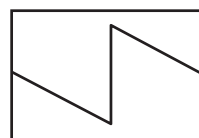

Ramp-down wave

## 4.2 Setting the Frequency

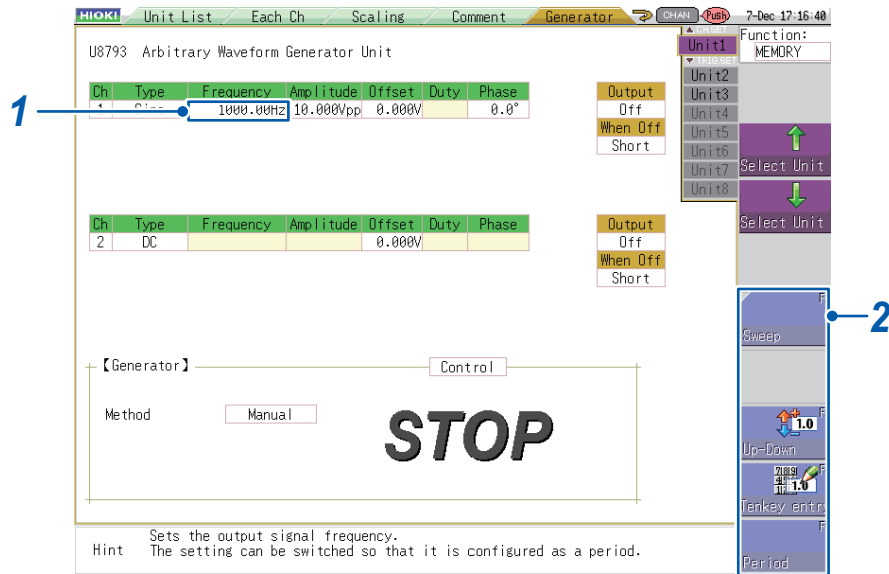

- 1 Select the **[Frequency]** setting.
- 2 Press a function key (**F1** to **F5**) or select a button with the mouse.

Sweep	p. 41
Up-Down	p. 18
Tenkey entry	p. 19
Period	Allows you to enter the setting as a period instead of a frequency. This value can be set only by means of numeric keypad input. (p. 19)

Valid frequency setting range:  
 U8793: 0 Hz to 100 kHz (in 0.01 Hz increments)  
 MR8790: 0 Hz to 20 kHz (in 1 Hz increments)

Valid period setting range:  
 U8793: 0 sec. to 100 sec.  
 MR8790: 0 sec. to 1 sec.

The period can be set as desired within the above range. However, the period of the waveform that is actually output will be the period of the waveform corresponding to the valid frequency setting that would produce the period closest to the user-entered period value.

## 4.3 Setting the Amplitude

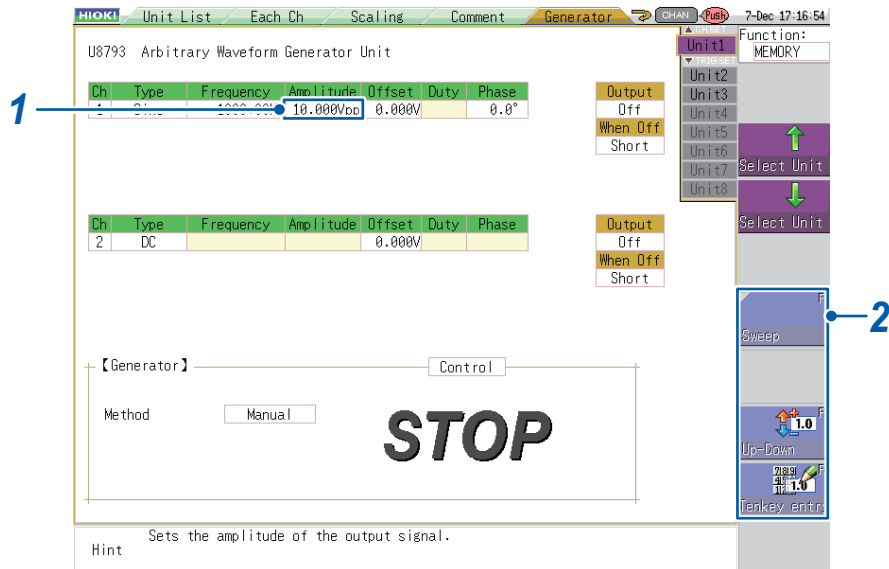

- 1 Select the **[Amplitude]** setting.
- 2 Press a function key (**F1** to **F5**) or select a button with the mouse.

Sweep	p. 41
Up-Down	p. 18
Tenkey entry	p. 19

Valid amplitude setting range: 0 V p-p to 20 V p-p (in 1 mV p-p increments)

The output voltage (amplitude + offset) range for which accuracy is guaranteed for each unit is as follows:

U8793: -10 V to +15 V

MR8790: -10 V to +10 V

If the value obtained by adding the amplitude and offset exceeds the range within which accuracy is guaranteed, part of the output waveform will be clamped as follows:

U8793: Upper limit of +16 V, lower limit of -11 V

MR8790: Upper limit of +14 V, lower limit of -14 V

# 4.4 Setting the Offset

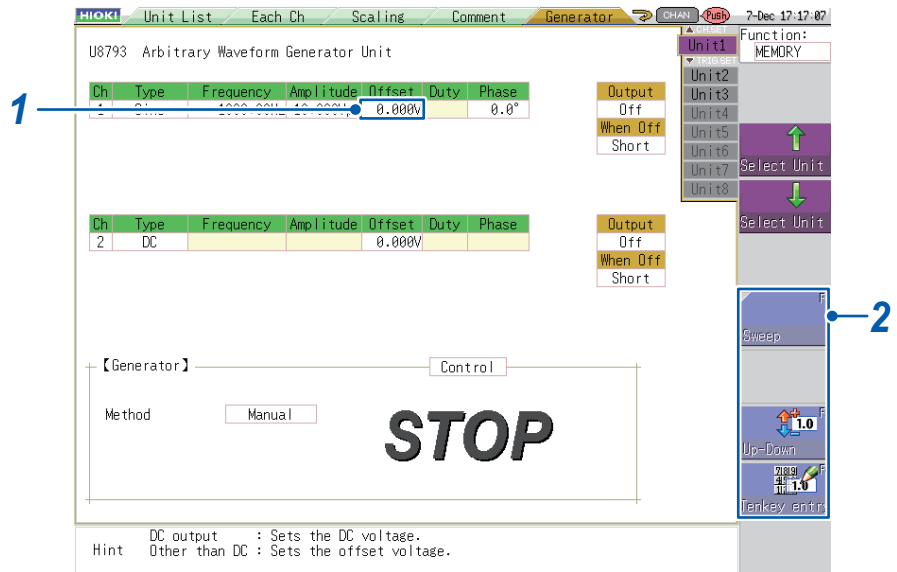

- 1 Select the **[Offset]** setting.
- 2 Press a function key (**F1** to **F5**) or select a button with the mouse.

Sweep	p.41
Up-Down	p.18
Tenkey entry	p.19

Valid offset setting range: -10 V to +15 V (in 1 mV increments) (U8793)  
 -10 V to +10 V (in 1 mV increments) (MR8790)

When the waveform type is set to DC, the set offset value determines the DC voltage that is output.  
 The output voltage (amplitude + offset) range for which accuracy is guaranteed for each unit is as follows:  
 U8793: -10 V to +15 V  
 MR8790: -10 V to +10 V

If the value obtained by adding the amplitude and offset exceeds the range within which accuracy is guaranteed, part of the output waveform will be clamped as follows:  
 U8793: Upper limit of +16 V, lower limit of -11 V  
 MR8790: Upper limit of +14 V, lower limit of -14 V

## 4.5 Setting the Duty (Pulse Wave Output Only)

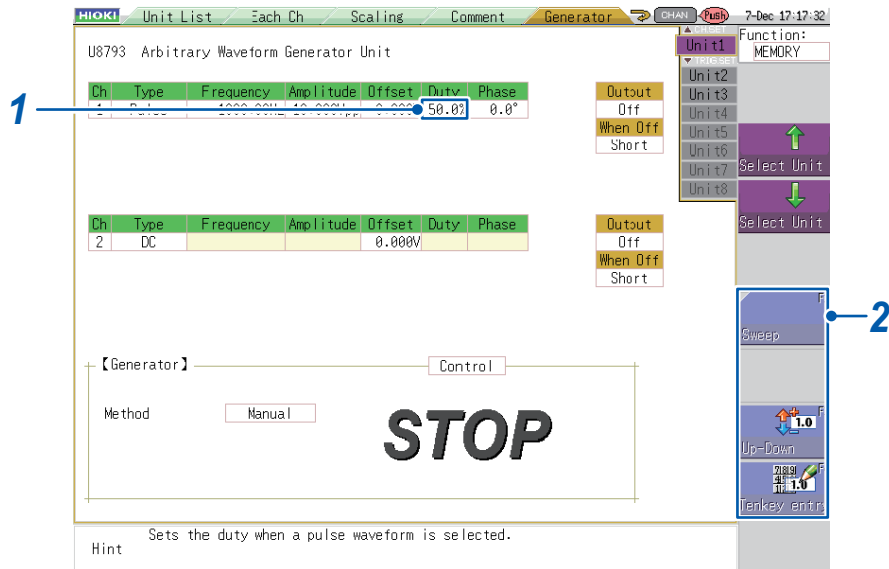

- 1 Select the **[Duty]** setting.
- 2 Press a function key (**F1** to **F5**) or select a button with the mouse.

Sweep	p. 41
Up-Down	p. 18
Tenkey entry	p. 19

Valid duty setting range: 0.1% to 99.9% (in 0.1% increments)

Setting a duty value that corresponds to a pulse width that is narrower than 500 ns may cause the shape of the output pulse to deteriorate or the pulse to disappear.

## 4.6 Setting the Phase

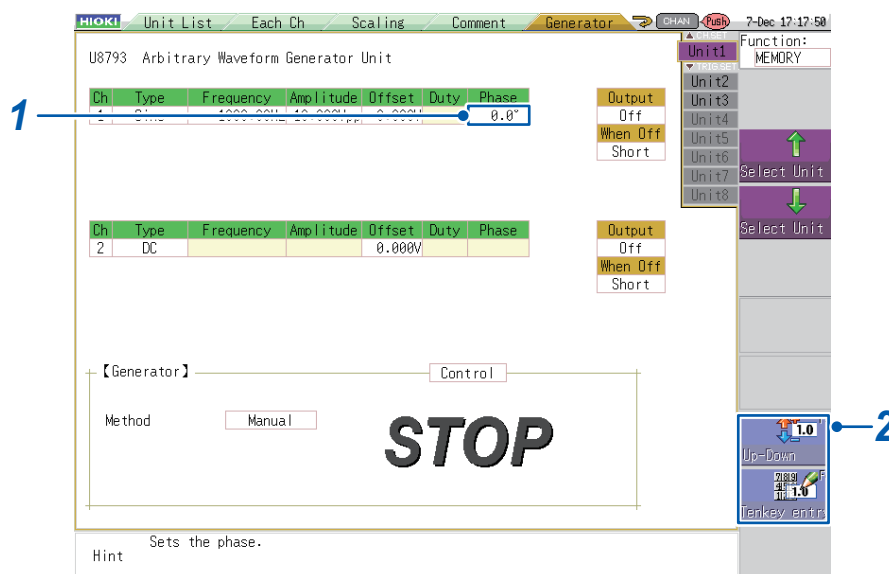

- 1 Select the **[Phase]** setting.
- 2 Press a function key (**F1** to **F5**) or select a button with the mouse.

Up-Down	p. 18
Tenkey entry	p. 19

Valid phase setting range:  $-360^{\circ}$  to  $+360^{\circ}$  (in  $0.1^{\circ}$  increments)

- Since the U8793 can generate output that is synchronized between channels on the same unit or between channels on different units, it can generate output based on the phase difference with the set channel.

Example

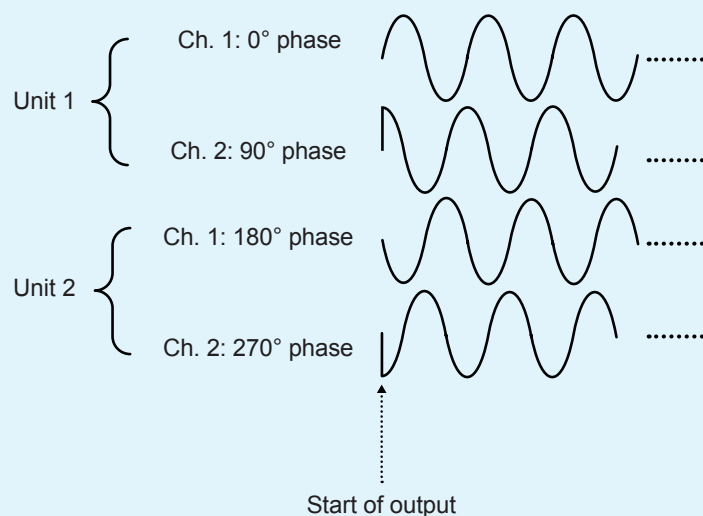

- Phase synchronization cannot be performed while using the sweep setting (p.41) or program setting (p.59).
- The MR8790 cannot generate output that is synchronized between channels on the same unit, between channels on different units, or with output from a U8793 or MR8791 unit.
- The MR8791 cannot generate output that is synchronized with output from a U8793 or MR8790 unit.

## 4.7 Setting the Output to ON or OFF

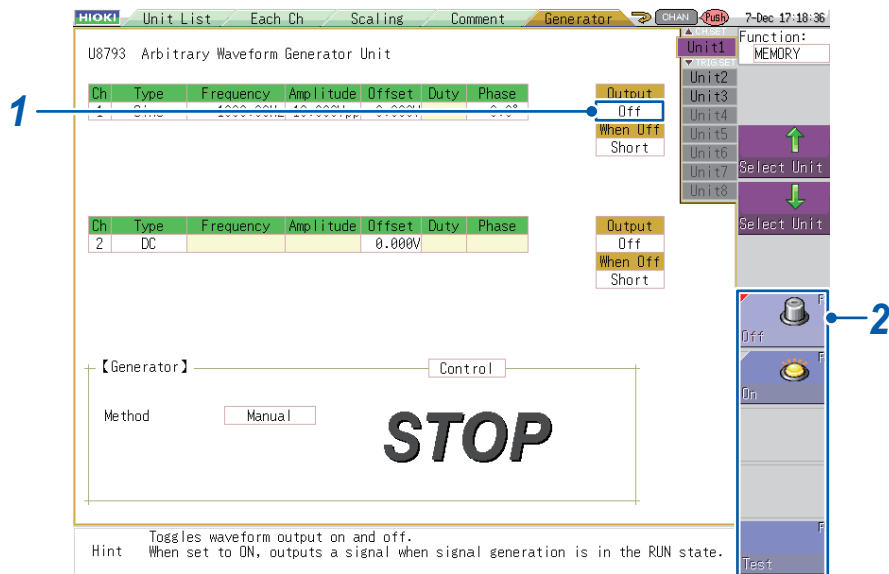

- 1 Select the **[Output]** setting.
- 2 Press a function key (**F1** to **F5**) or select a button with the mouse.

Off	Does not output a waveform, regardless of the state of Generator Control (p. 71). (Output indicator: Off)
On	Outputs a waveform when Generator Control (p. 71) is <b>[RUN]</b> . (Output indicator: Red)
Test	Generates test output of the set waveform. (Output indicator: Red)

### After selecting **[Test]**

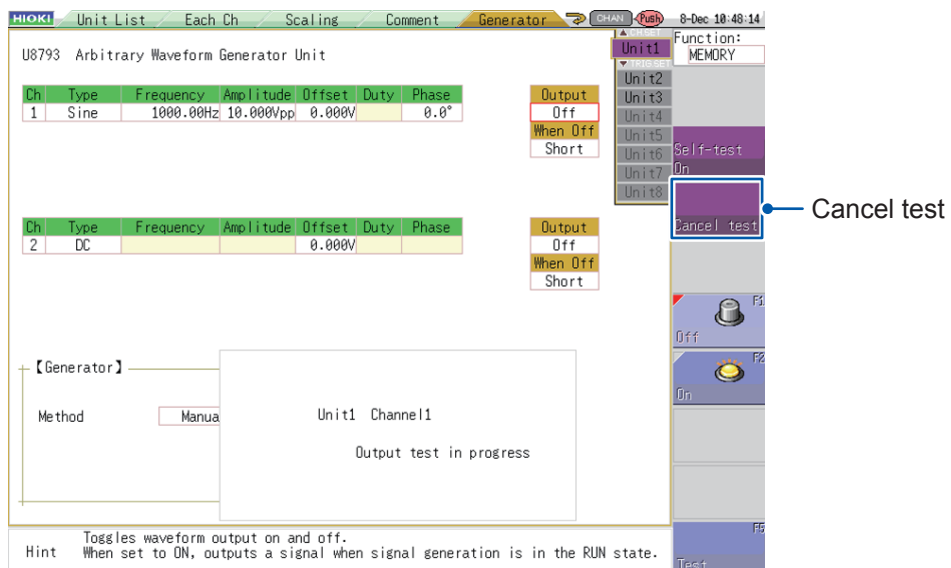

Pressing **TRIG.SET** (**TRIG.SET**) stops test output.

This test mode does not provide functionality for judging test results with the unit. You are responsible for determining whether the set FG waveform is being properly output during the output test.

# 4.8 Setting Behavior When Output is OFF

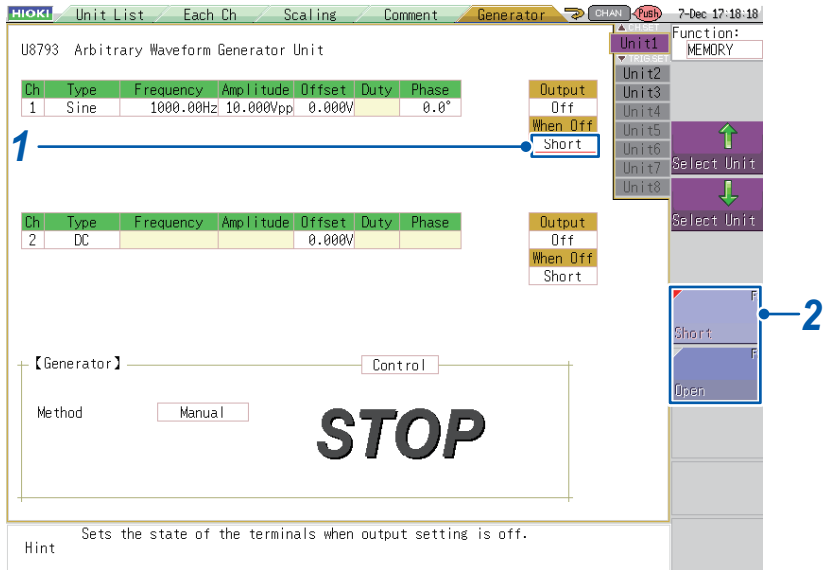

- 1 Select the **[When Off]** setting.
- 2 Press a function key (**F1** to **F5**) or select a button with the mouse.

Short	<p>When the output (p.26) is OFF, places the output terminal in a shorted state by separating it from the unit's internal circuitry and introducing resistance.</p> <p>Internal circuitry</p> <p>U8793: approx. 100 Ω MR8790: approx. 20 Ω</p> <p>Output terminal</p>
Open	<p>When the output (p.26) is OFF, places the output terminal in an open state by separating it from the unit's internal circuitry.</p> <p>Internal circuitry</p> <p>Output terminal</p>



# 5

## Setting Pulse and Pattern Output (MR8791)

This section describes the settings that are available when an MR8791 Pulse Generator Unit is selected on the Generator screen (signal generation settings screen) (p. 15).

### 5.1 Setting the Mode

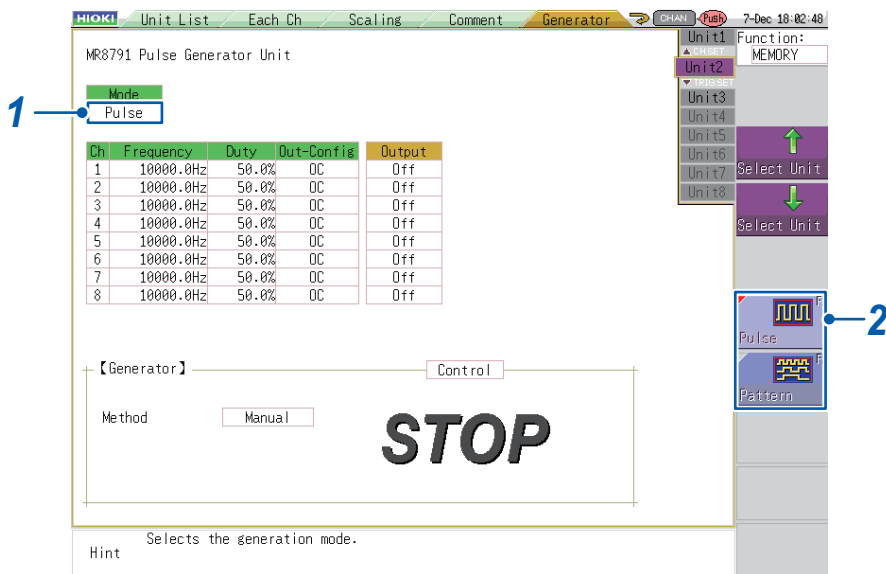

- 1 Select the **[Mode]** setting.
- 2 Press a function key (**F1** to **F5**) or select a button with the mouse.

Pulse	Outputs a continuous pulse waveform. (p.30) The frequency and duty can be set separately for each channel.
Pattern	Outputs a user-edited pattern. Patterns are edited using the SF8000 Waveform Maker. (p.34)

- Patterns are edited using the SF8000 Waveform Maker. For more information about how to edit patterns, see “13.9 Pulse Pattern Mode” (p. 117).
- The Pattern setting can only be selected when the Channels to use setting on the Memory HiCorder in which the MR8791 is installed is set to the maximum number of channels. The Channels to use setting can be configured under [Basic Setting] on the [STATUS] screen. For more information, see the instruction manual for the Memory HiCorder in which the unit is installed.

## 5.2 Setting the Pulse Mode

### Setting the frequency

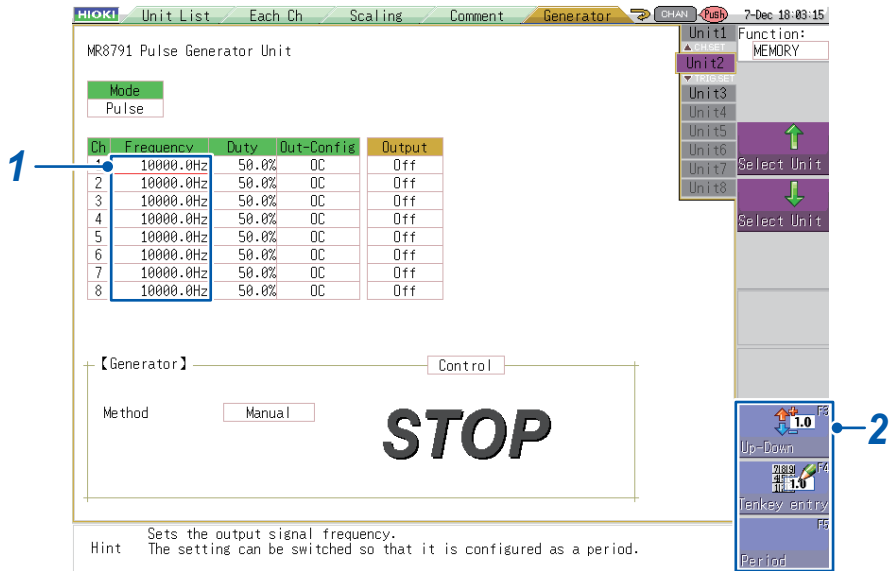

- 1** Select the **[Frequency]** setting.
- 2** Press a function key (**F1 to F5**) or select a button with the mouse.

Up-Down	p. 18
Tenkey entry	p. 19
Period	Allows you to enter the setting as a period instead of a frequency. This value can be set only by means of numeric keypad input. (p. 19)

Valid frequency setting range: 0 Hz to 20 kHz (in 0.1 Hz increments)

Valid period setting range: 0 sec. to 10 sec.

The period can be set as desired within the above range. However, the period of the waveform that is actually output will be the period of the waveform corresponding to the valid frequency setting that would produce the period closest to the user-entered period value.

## Setting the duty

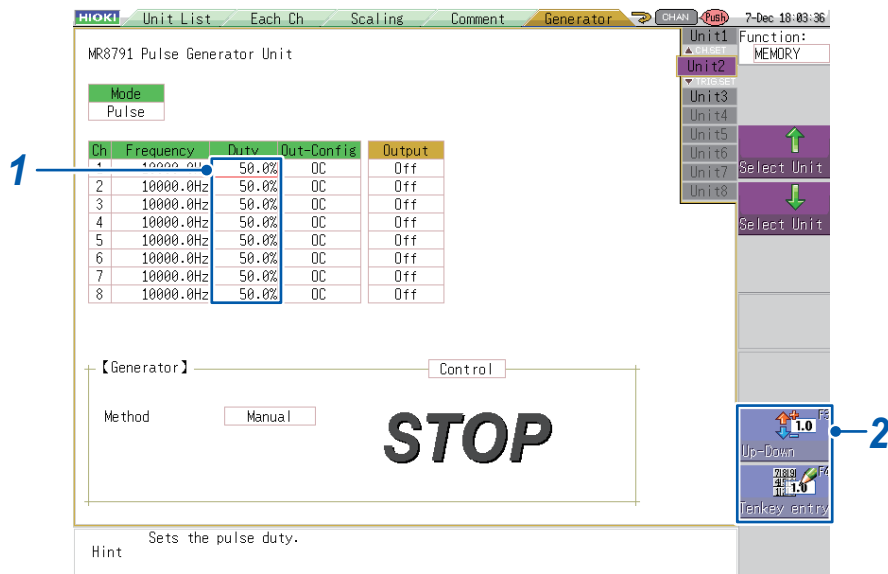

- 1 Select the [Duty] setting.
- 2 Press a function key (F1 to F5) or select a button with the mouse.

Up-Down	p. 18
Tenkey entry	p. 19

Valid duty setting range: 0% to 100% (in 0.1% increments)

- Entering a setting of 0% will fix the output level to LOW, while entering a setting of 100% will fix the output level to HIGH. The unit will not generate pulse output in either case.
- When the duty is set to 100%, the output waveform will be fixed at the HIGH level, even when output is set to OFF (p.33).
- Setting a duty value that corresponds to a pulse width that is narrower than 1  $\mu$ s may cause the pulse to disappear.

## Setting the output type

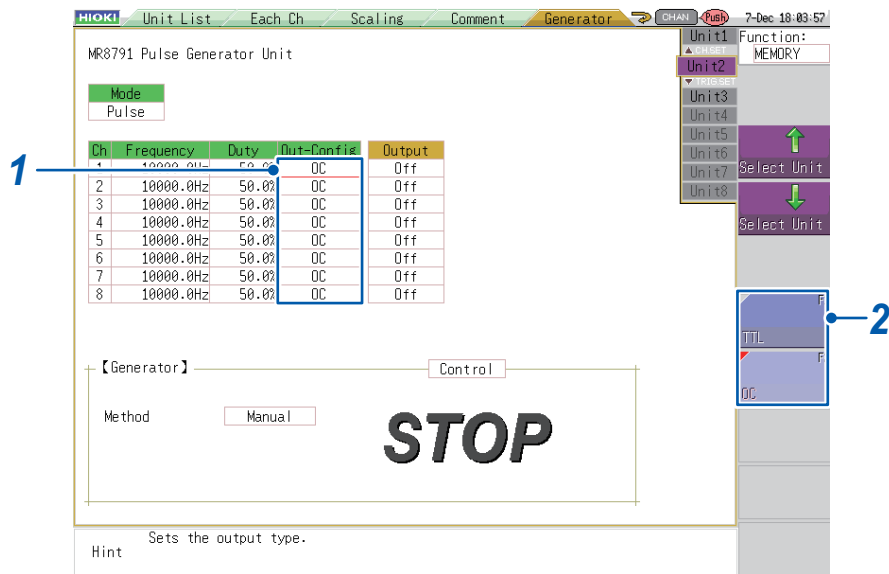

- 1 Select the **[Out-Config]** setting.
- 2 Press a function key (**F1** to **F5**) or select a button with the mouse.

TTL	Selects a TTL-level pulse waveform (0 to 5 V of amplitude).
OC	Selects a pulse waveform consisting of open-collector output.

- Both channels share the same GND and are not isolated.

### Open-collector output

- The voltage applied between the collector and emitter must be 50 V or less.
- The maximum response time (10% to 90%) is approximately 5  $\mu$ s (with a load capacitance of 1000 pF and a pull-up resistance of 1 k $\Omega$ ) (reference value).

## Setting output

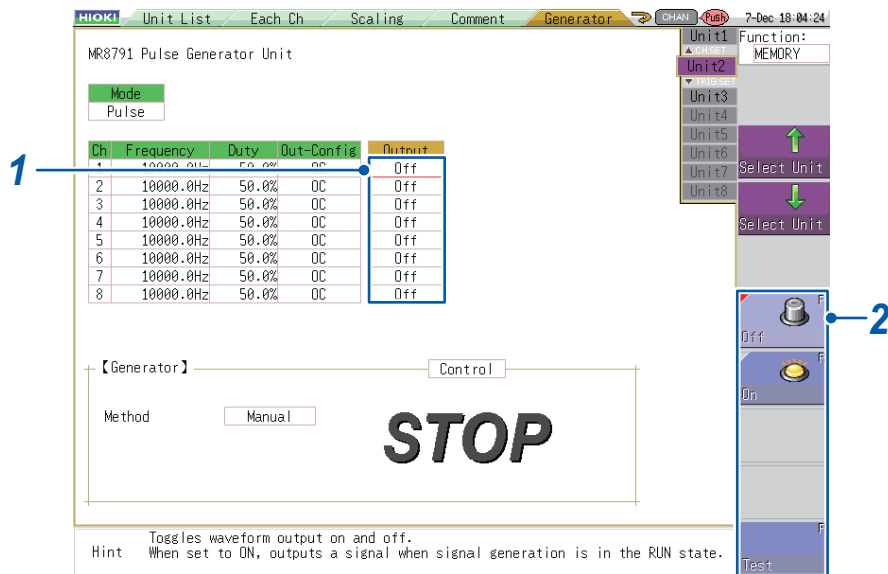

- 1 Select the **[Output]** setting.
- 2 Press a function key (**F1** to **F5**) or select a button with the mouse.

Off	Does not output a waveform, regardless of the state of Generator Control (p. 71).
On	Outputs the set pulse waveform when Generator Control (p. 71) is <b>[RUN]</b> .
Test	Generates test output of the set waveform.

A HIGH-level signal may be output momentarily when the power is turned on or off.

### After selecting **[Test]**

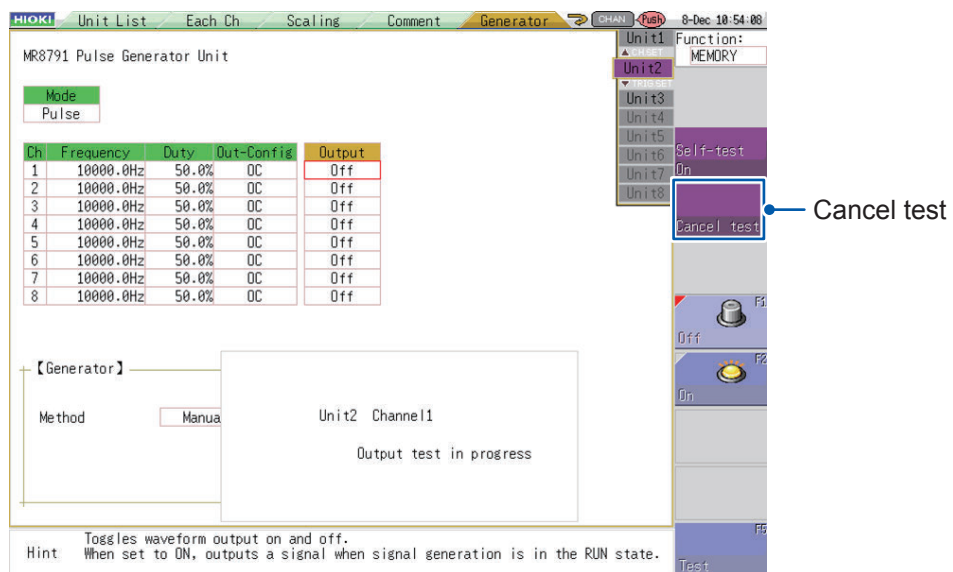

Pressing **(TRIG.SET)** (**TRIG.SET**) stops test output.

This test mode does not provide functionality for judging test results with the unit. You are responsible for determining whether the set pulse waveform is being properly output during the output test.

## 5.3 Setting the Pattern Mode

### Setting the output type

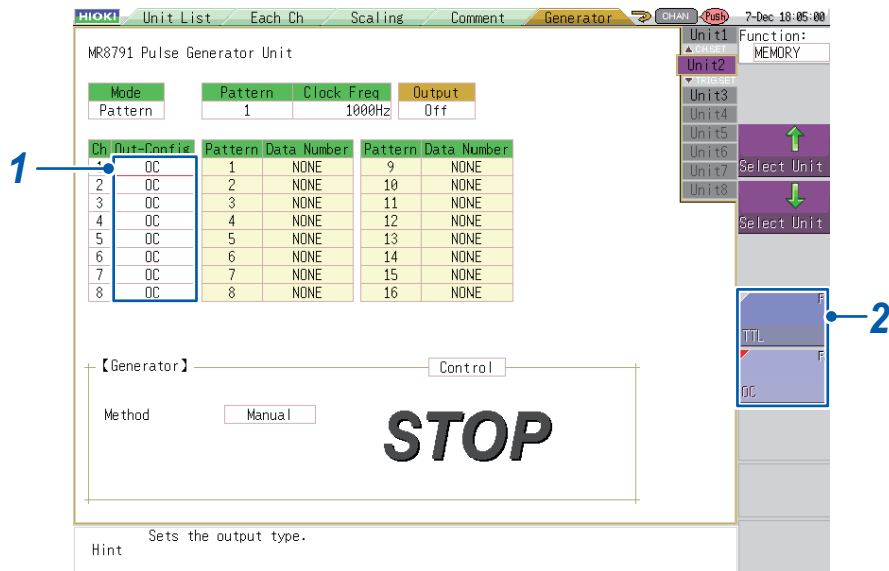

- 1 Select the **[Out-Config]** setting.
- 2 Press a function key (**F1** to **F5**) or select a button with the mouse.

TTL	Selects a TTL-level pulse waveform (0 to 5 V of amplitude).
OC	Selects a pulse waveform consisting of open-collector output.

- Both channels share the same GND and are not isolated.

#### Open-collector output

- The voltage applied between the collector and emitter must be 50 V or less.
- The maximum response time (10% to 90%) is approximately 5  $\mu$ s (with a load capacitance of 1000 pF and a pull-up resistance of 1 k $\Omega$ ) (reference value).

## Setting the pattern to use

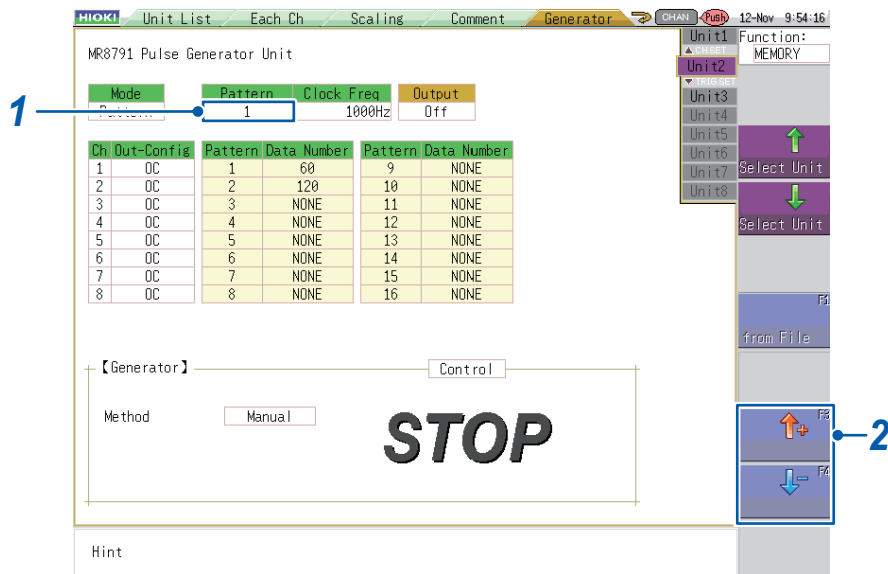

- 1 Select the **[Pattern]** setting.
- 2 Press a function key (**F1** to **F5**) or select a button with the mouse.

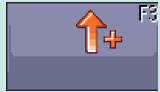
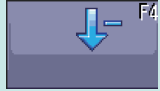
Register: From file	Select this function key when registering the pattern. (p.36)
 	Selects the pattern number to use.

- When output is in the stopped state, the first registered pattern will be output.
  - Registered patterns will be erased if the [Channels to use] setting on the Memory HiCorder in which the MR8791 is installed is changed to any value other than the maximum number of channels.
  - Pattern data will be erased if the instrument's power supply is interrupted. Register pattern data again after turning the instrument back on.
- The Channels to use setting can be configured under [Basic Setting] on the [STATUS] screen. For more information, see the instruction manual for the Memory HiCorder in which the unit is installed.

## Method for registering a pattern

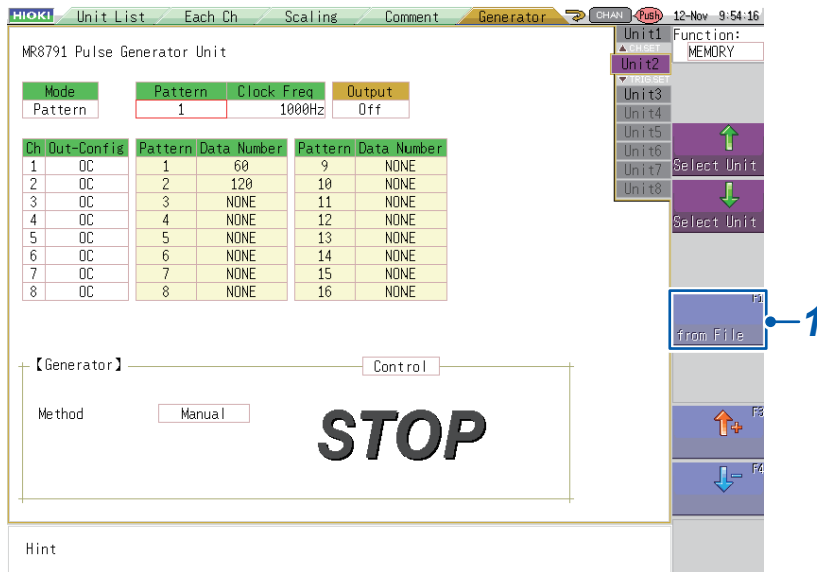

- 1 Press the function key (F1) or select [Register: From file] with the mouse to display the File screen in accordance with the guidance on the screen.

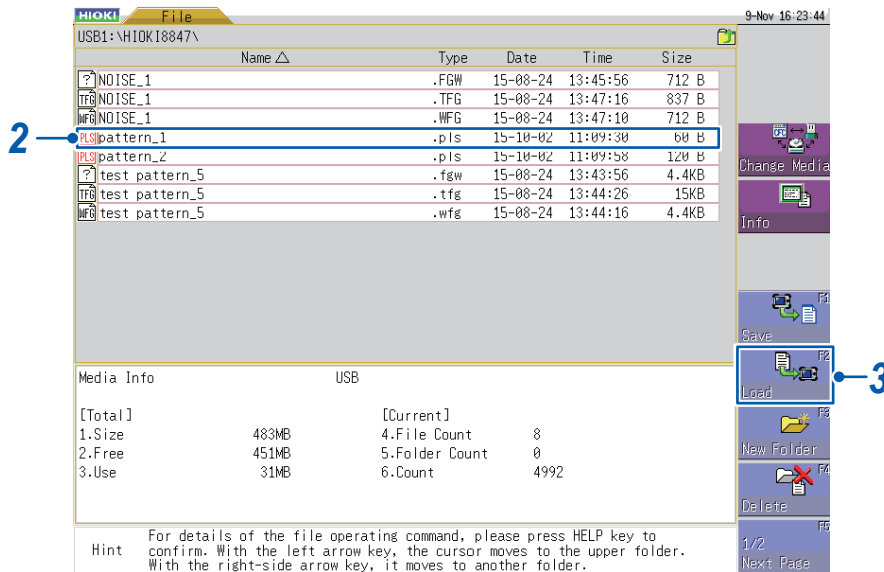

- 2 Select the file to register (with an extension of “.pls”).
- 3 Press the function key (F2) or select [Load] with the mouse. (The Register Settings screen will be displayed.)

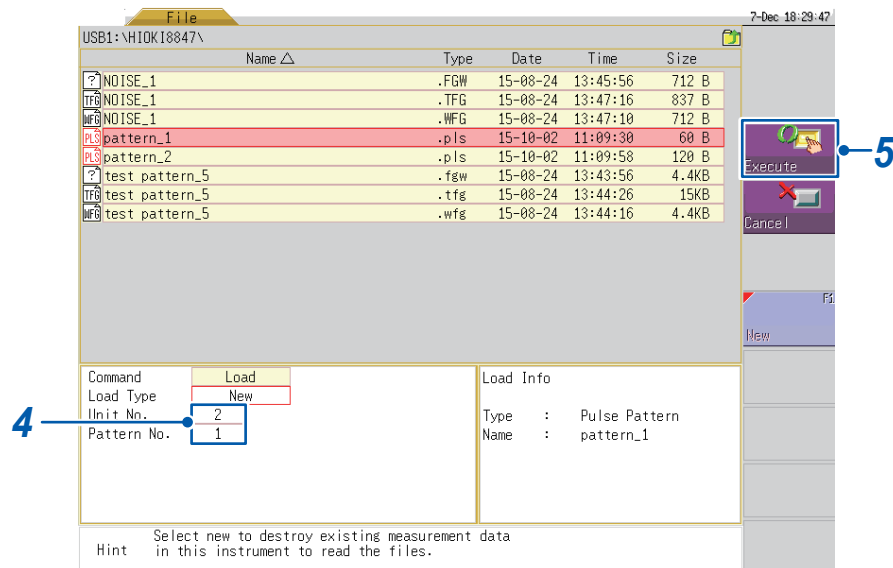

**4** Set the target unit number and pattern number.

**5** Press **CH.SET** (**CH.SET**) (to register the file).

- Insert the media before performing any operations on the File screen.
- Up to 16 pattern files can be registered.
- To cancel the file register operation, press **TRIG.SET** (**TRIG.SET**) or **ESC** (**ESC**).
- The extension for pattern files is “.pls.”

**5**

Setting Pulse and Pattern Output (MR8791)

## Setting the clock frequency

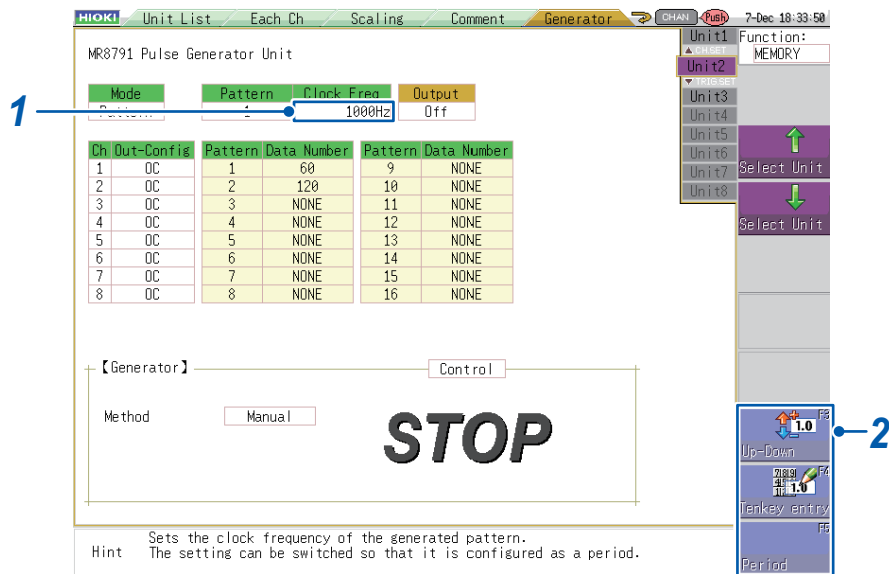

- 1 Select the **[Clock Freq]** setting.
- 2 Press a function key (**F1** to **F5**) or select a button with the mouse.

Up-Down	p. 18
Tenkey entry	p. 19
Period	Allows you to enter the setting as a period instead of a frequency. This value can be set only by means of numeric keypad input. (p. 19)

Valid clock frequency setting range: 0 Hz to 120 kHz (in 10 Hz increments)

Valid clock period setting range: 0 sec. to 0.1 sec.

The clock period can be set as desired within the above range. However, the clock period of the waveform that is actually output will be the clock period of the waveform corresponding to the valid clock frequency setting that would produce the clock period closest to the user-entered clock period value.

## Setting output

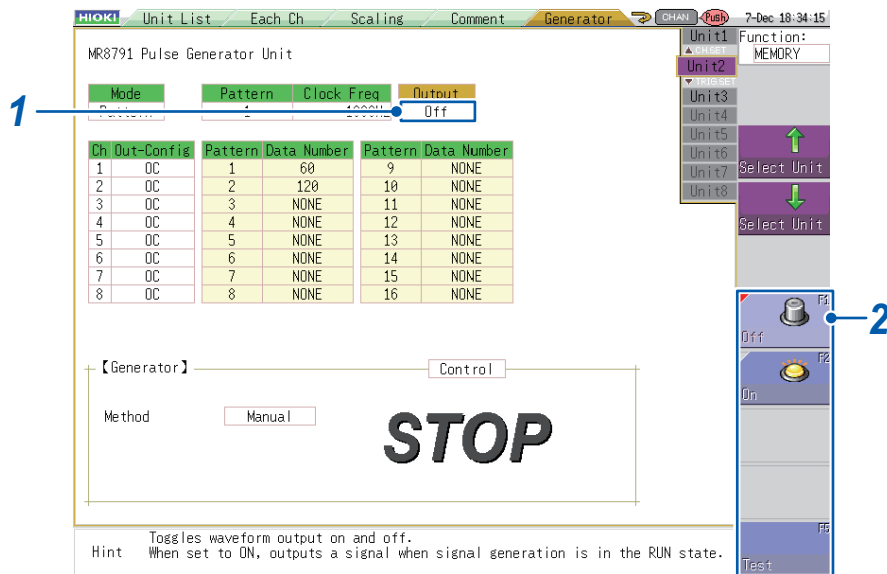

- 1 Select the [Output] setting.
- 2 Press a function key (F1 to F5) or select a button with the mouse.

Off	Does not output a waveform, regardless of the state of Generator Control (p.71).
On	Outputs the set pulse waveform when Generator Control (p.71) is [RUN].
Test	Generates test output of the set waveform.

### After selecting [Test]

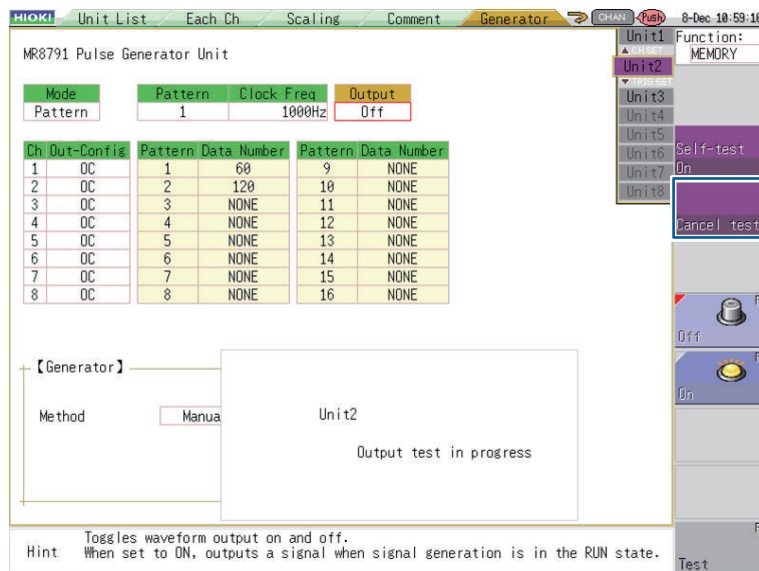

Pressing **TRIG.SET** (**TRIG.SET**) stops test output.

This test mode does not provide functionality for judging test results with the unit. You are responsible for determining whether the selected pattern waveform is being properly output during the output test.



# 6

## Sweep Setting (U8793)

### 6.1 Selecting the Sweep Type

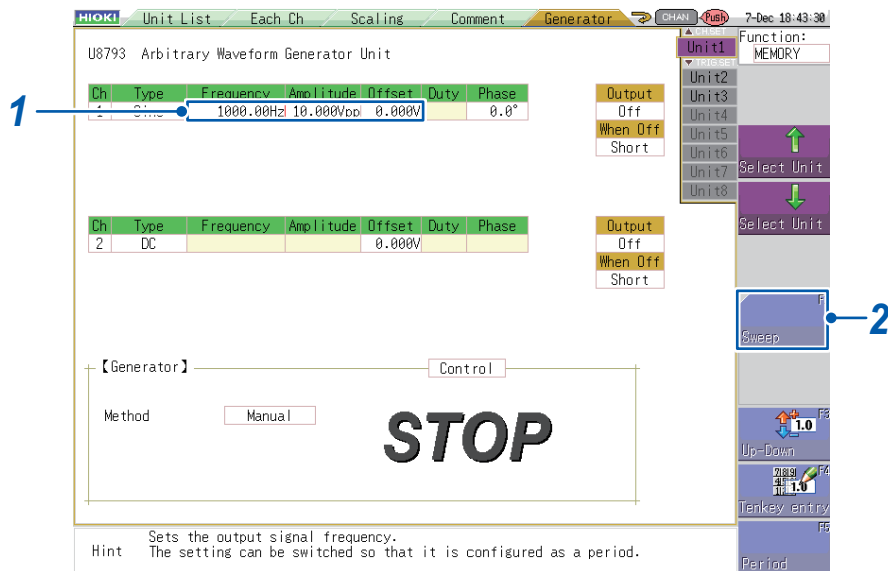

1 Select the type of sweep operation you wish to perform.

Type	Selectable settings
DC	n/a
Sine Square Triangle Ramp-up Ramp-down	Frequency, amplitude, offset (Simultaneous sweep is supported.)
Pulse	Frequency, amplitude, offset, duty (Simultaneous sweep is supported. However, frequency and duty cannot be set at the same time.)
Arbitrary	Clock frequency, amplitude adjustment, offset (Simultaneous sweep is supported.)

2 Press the function key (F1) or select [Sweep] with the mouse.  
(When [Sweep] is selected, you will be able to enter the end value (p.43) underneath the selected setting.)

#### Canceling the sweep setting

The sweep setting can be canceled by pressing the function key (F1) again or by selecting [Sweep] with the mouse.

## 6.2 Setting the Start Value

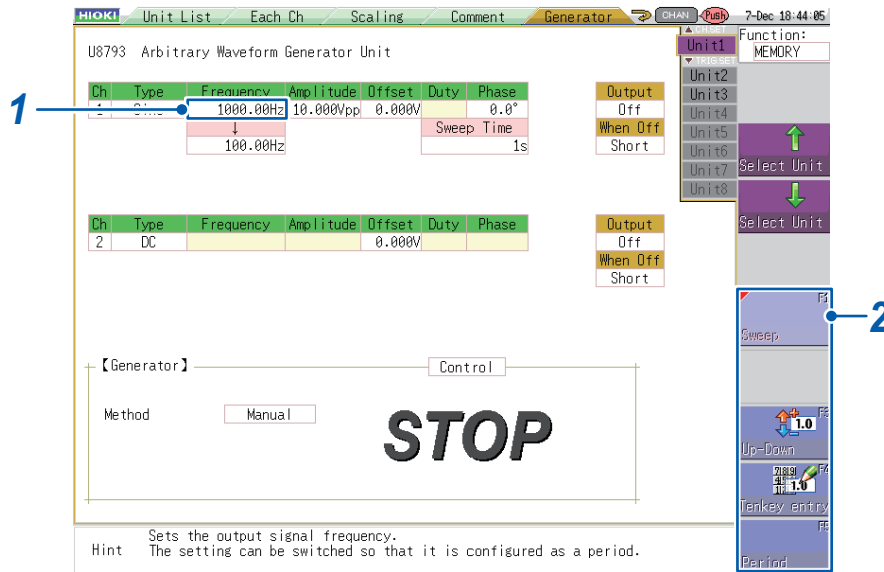

- 1 Select the start value setting.
- 2 Press a function key (**F1** to **F5**) or select a button with the mouse.

Up-Down	p. 18
Tenkey entry	p. 19
Period	Allows you to enter the setting as a period instead of a frequency. This value can be set only by means of numeric keypad input. (p. 19)

When the frequency is set to the sweep setting, you can set the period with the function key (**F5**). When you do so, the end value will also switch to the period setting. Values can only be set with numeric key input.

Valid frequency setting range: 0 Hz to 100 kHz (in 0.01 Hz increments)

Valid period setting range: 0 sec. to 100 sec.

The period can be set as desired within the above range. However, the period of the waveform that is actually output will be the period of the waveform corresponding to the valid frequency setting that would produce the period closest to the user-entered period value.

For duty-ratio sweeping, an error may become larger between a duty-starting value of a pulse waveform outputted and the set value.

The smaller the difference is between the period of the set pulse waveform and the sweeping time, the larger the error becomes.

## 6.3 Setting the End Value

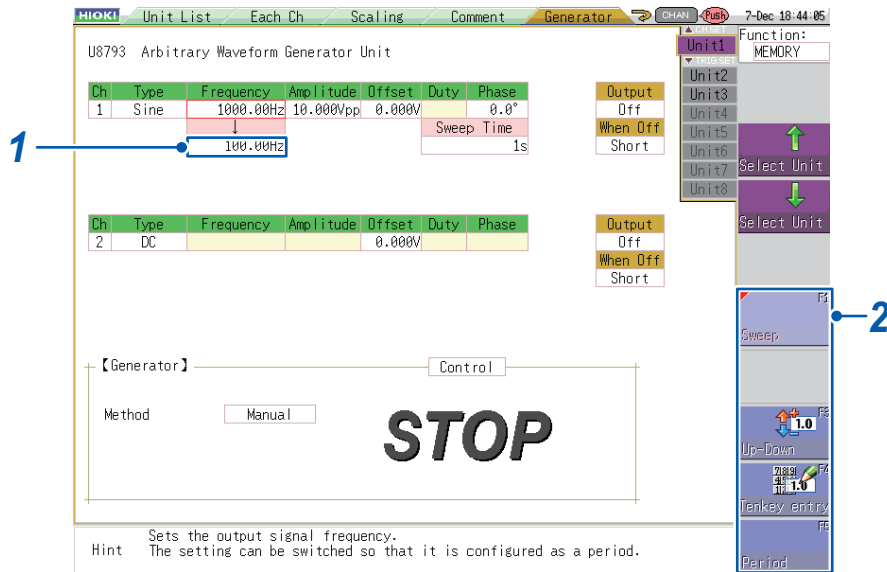

- 1 Select the end value setting.
- 2 Press a function key (**F1** to **F5**) or select a button with the mouse.

Up-Down	p. 18
Tenkey entry	p. 19
Period	Allows you to enter the setting as a period instead of a frequency. This value can be set only by means of numeric keypad input. (p. 19)

Valid frequency setting range: 0 Hz to 100 kHz (in 0.01 Hz increments)  
 Valid period setting range: 0 sec. to 100 sec.

The period can be set as desired within the above range. However, the period of the waveform that is actually output will be the period of the waveform corresponding to the valid frequency setting that would produce the period closest to the user-entered period value.

For duty-ratio sweeping, an error may become larger between a duty-ending value of a pulse waveform outputted and the set value.  
 The smaller the difference is between the period of the set pulse waveform and the sweeping time, the larger the error becomes.

## 6.4 Setting the Sweep Time

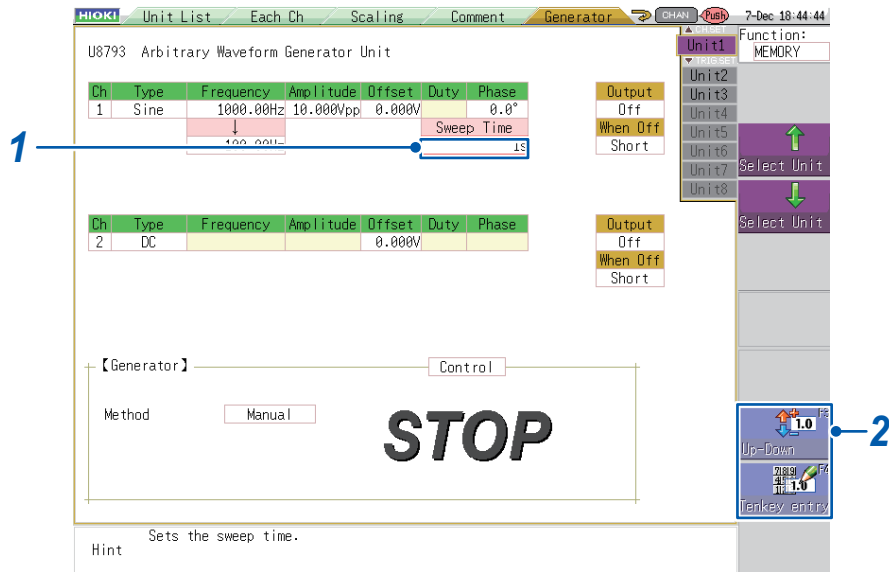

- 1 Select the [Time] setting.
- 2 Press a function key (F1 to F5) or select a button with the mouse.

Up-Down	p. 18
Tenkey entry	p. 19

Valid sweep time setting range: 0.01 ms to 1000 sec. (in 0.01 ms increments)

# 7

## Arbitrary Waveform Settings (U8793)

This section describes the settings that are available when a U8793 Arbitrary Waveform Generator Unit is selected on the Generator screen (signal generation settings screen) (p. 15) and the waveform type is set to **[Arbitrary]**

### 7.1 Setting the Waveform Type

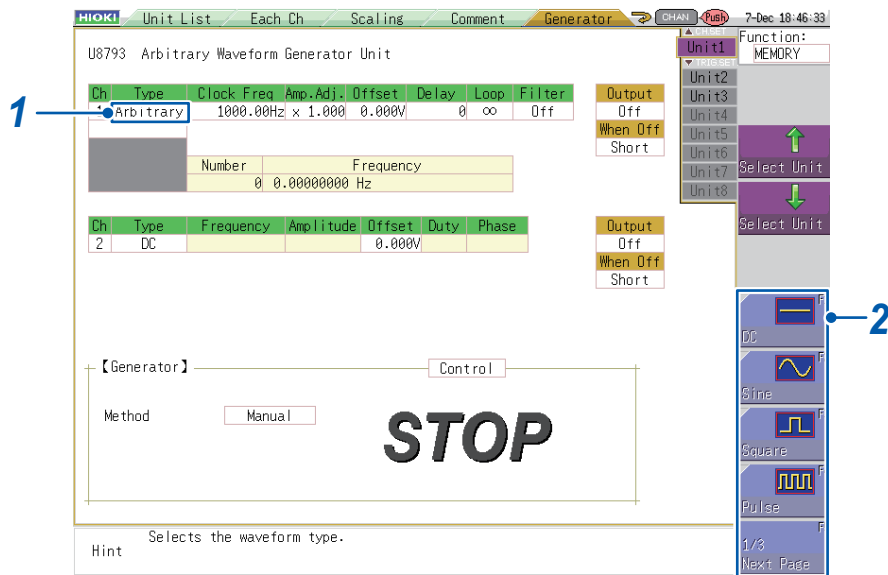

- 1 Select the **[Type]** setting.
- 2 Press a function key (**F1** to **F5**) or select the **[Arbitrary]** button (2/3 pages) with the mouse.

## 7.2 Registering a Waveform

This section describes how to register the desired waveform data in the U8793's memory. You can register either data created using the SF8000 Waveform Maker or data measured with a Memory HiCorder. For more information about how to create waveforms with the SF8000 Waveform Maker, see "13 Waveform Maker" (p.85).

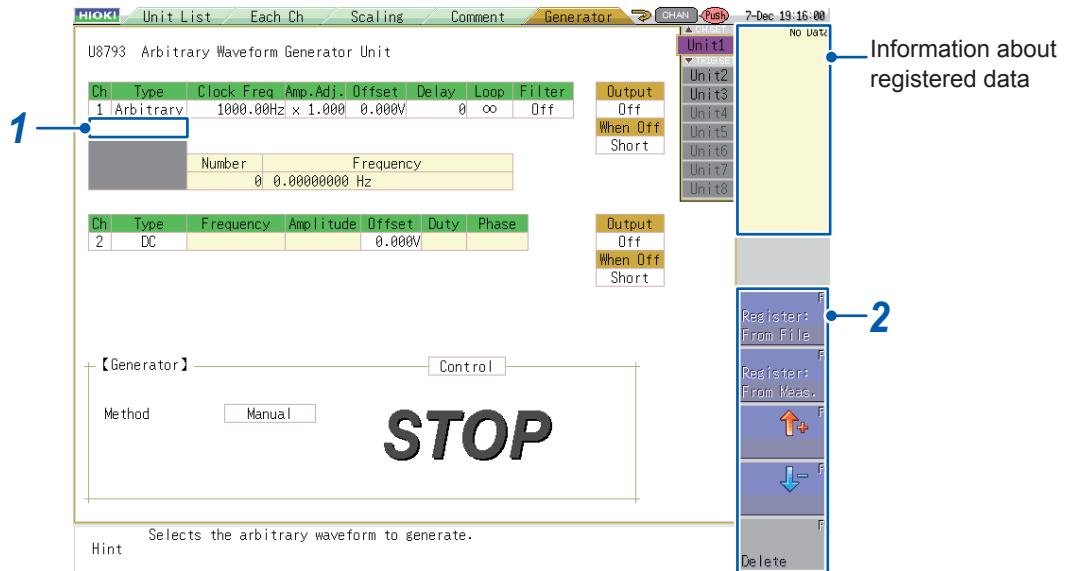

- 1 Select the setting under [Type].
- 2 Press a function key (F1 to F5) or select a button with the mouse.

Register: From File	Registers data saved on external media. (p.49)
Register: From Meas.	Registers data measured using the memory function. The data can be registered once the MEM file is loaded into the Memory HiCorder from external media. (p.47)
Delete	Deletes data that has been registered in the U8793's memory. If the maximum eight waveforms have already been registered, you must delete one of the previously registered waveforms before you can register a new waveform.

- Data for up to eight arbitrary waveforms can be registered for each channel.
- If deleted arbitrary waveform data is used in program function (p.59) steps, those steps will also be deleted.

## Registering data measured with a Memory HiCorder

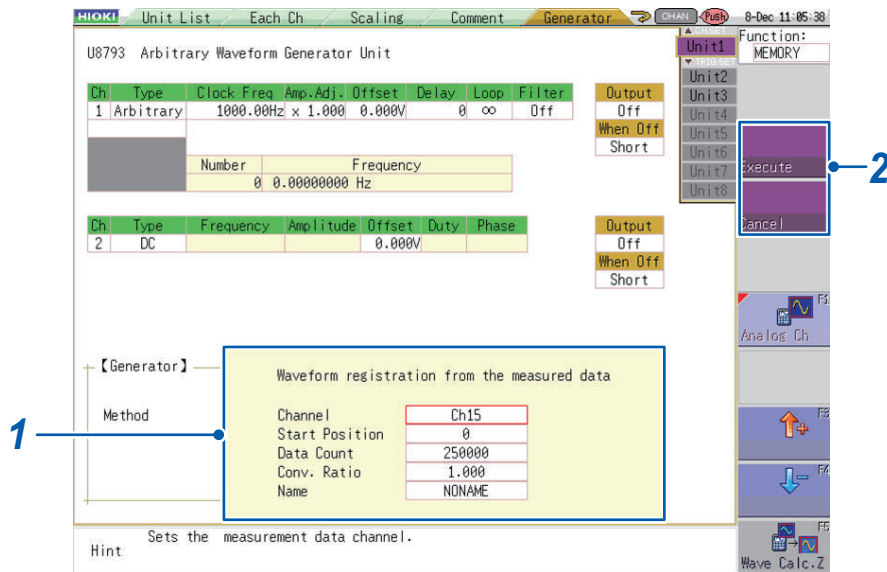

**1** Set information about the measurement data to be registered.

Channel	Sets the measurement channel number for the measurement data being registered (Analog waveform: Ch, Waveform calculation: Z). This parameter can be set by function key ( <b>F3</b> , <b>F4</b> ).
Start Position	Sets the start position for the range of measurement data to be registered. This parameter can be set by function key ( <b>F1</b> : entire waveform; <b>F2</b> : waveform between A and B; <b>F3</b> : up-down; <b>F4</b> : numeric keypad input). Selecting [ <b>F1</b> : Entire waveform] will cause the start position to be set to 0, while selecting [ <b>F2</b> : Waveform between A and B] will cause the start position to be set to the position of the A cursor.
Data Count	Sets the number of data points in the measurement data to be registered. This parameter can be set by function key ( <b>F1</b> : entire waveform; <b>F2</b> : waveform between A and B; <b>F3</b> : up-down; <b>F4</b> : numeric keypad input). Selecting [ <b>F1</b> : Entire waveform] will cause the data count to be set to the total number of measured data points, while selecting [ <b>F2</b> : Waveform between A and B] will cause the data count to be set to the number of data points between the A and B cursors (or if only the A cursor is displayed, the number of data points occurring after the A cursor).
Conv. Ratio	Sets the scaling factor to apply to the voltage values in the measurement data to be registered when registering the data. The valid setting range for this parameter is 0.001× to 100.000×. The parameter can be set by function key ( <b>F3</b> : up-down; <b>F4</b> : numeric keypad input).
Name	Sets the name of the data. Up to 16 single-byte characters or 8 double-byte characters can be entered.

**2** **CH.SET** Press (**CH.SET**) to register the data in the unit's memory. To cancel the operation without registering any data, press **TRIG.SET** (**TRIG.SET**) or **ESC** (**ESC**).

**After registering data**

Name of the registered arbitrary waveform

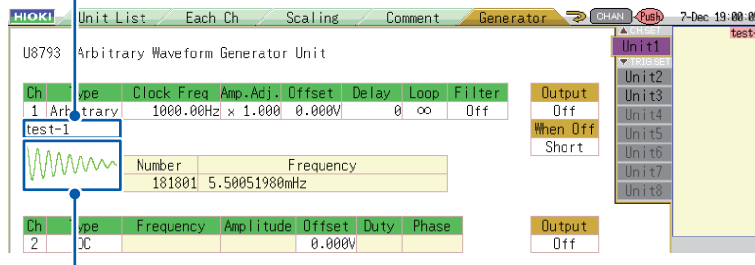
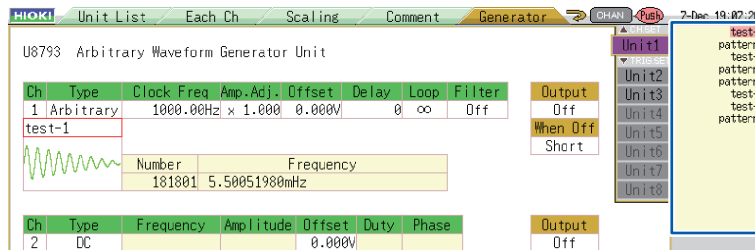

Image of the registered waveform

To change the arbitrary waveform data that is output, select the desired waveform from the list of registered arbitrary waveform data. To do so, move the cursor to the data name field and press a function key (**F3**, **F4**).



List of registered arbitrary waveform data

It takes approximately 30 seconds to register arbitrary waveform data with 250,000 data points.

**About the data count**

Measurement data containing up to 250,000 data points can be registered. If you attempt to register measurement data containing more than this maximum number of data points, only 250,000 data points will be registered.

**About the conversion ratio**

The range of voltages that can be output by the U8793 is -10 V to 15 V. If the measurement data being registered contains voltage values that exceed this range, a conversion ratio can be set so that the registered waveform remains within the -10 V to 15 V range.

Example:

You wish to register measurement data describing an anomalous waveform for a 100 V AC power supply and then output it via an amplifier connected to the U8793's output.

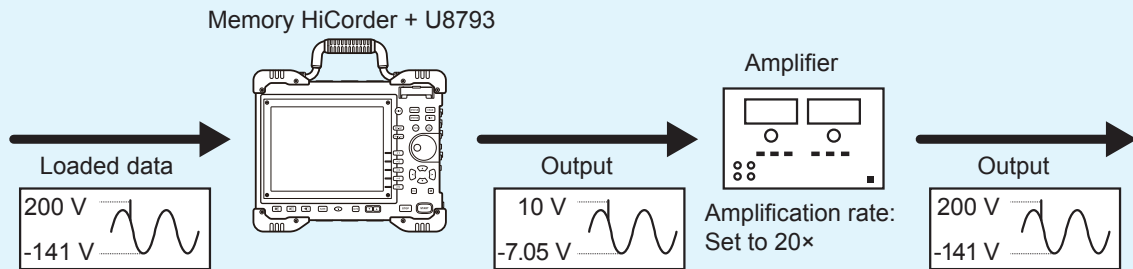

Measured data is registered into the U8793's memory after being multiplied by a conversion rate of 0.05.

(Use an amplifier with an input resistance of at least 2 kΩ for external signal input.)

## Registering data created with the SF8000 Waveform Maker

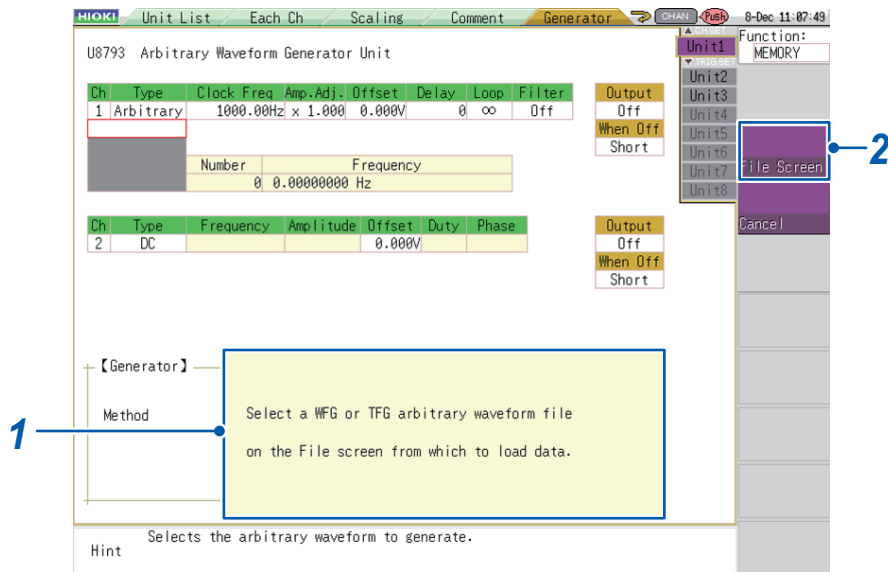

- 1 Verify that the confirmation window is being displayed.
- 2 Press **CH.SET** (**CH.SET**). (The File screen will be displayed.)

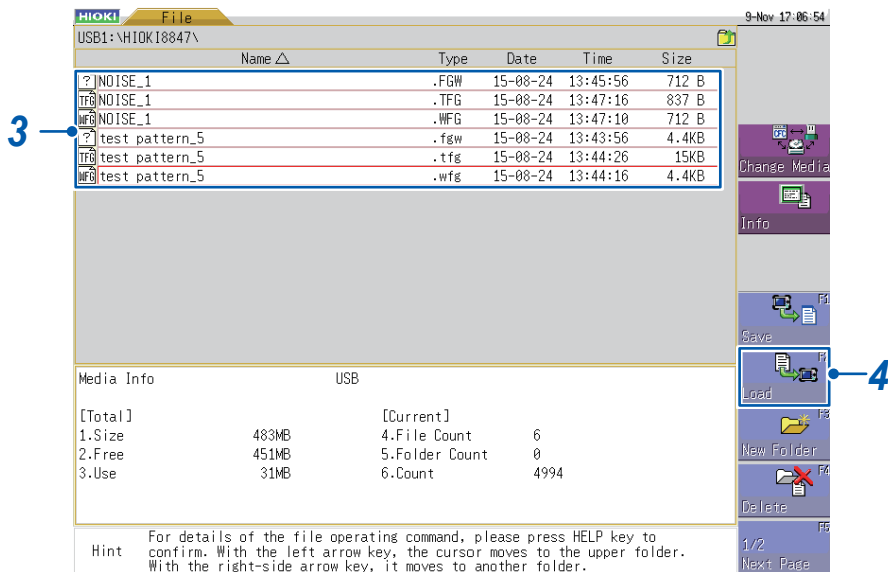

- 3 Select the data you wish to register.
- 4 Press the function key (**F2**) or select **[Load]** with the mouse. (The Register Settings screen will be displayed.)

## Registering a Waveform

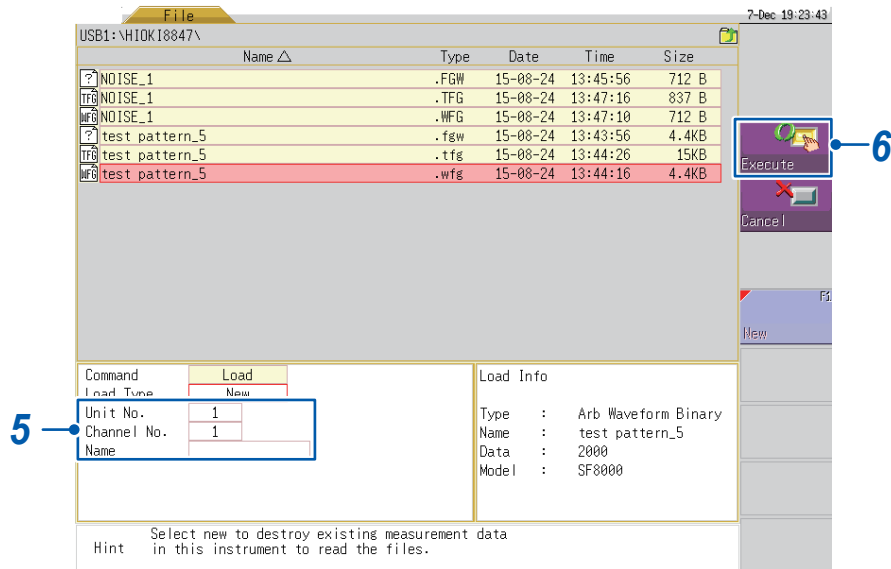

**5** Select the target unit number and channel number and enter the data name.

**6** Press **CH.SET** (**CH.SET**) (to register the data).

- Insert the media before performing any operations on the File screen.
- It takes approximately 30 seconds to register arbitrary waveform data with 250,000 data points.
- To cancel the data register operation, press **TRIG.SET** (**TRIG.SET**) or **ESC** (**ESC**).
- Only data with the extension “.wfg” or “.tfg” can be registered into the U8793’s memory. Files with the extension “.wfg” contain binary data, while files with the extension “.tfg” contain text data. Files with the extension “.fgw” can only be registered using the SF8000 Waveform Maker.

## 7.3 Setting the Clock Frequency

This section describes how to set the conversion clock frequency for the D/A converter when converting arbitrary waveform data to an analog signal with a D/A converter. The sweep setting may also be used. (p.41)

The frequency of the arbitrary waveform that is output is determined by the clock frequency and arbitrary waveform data count.

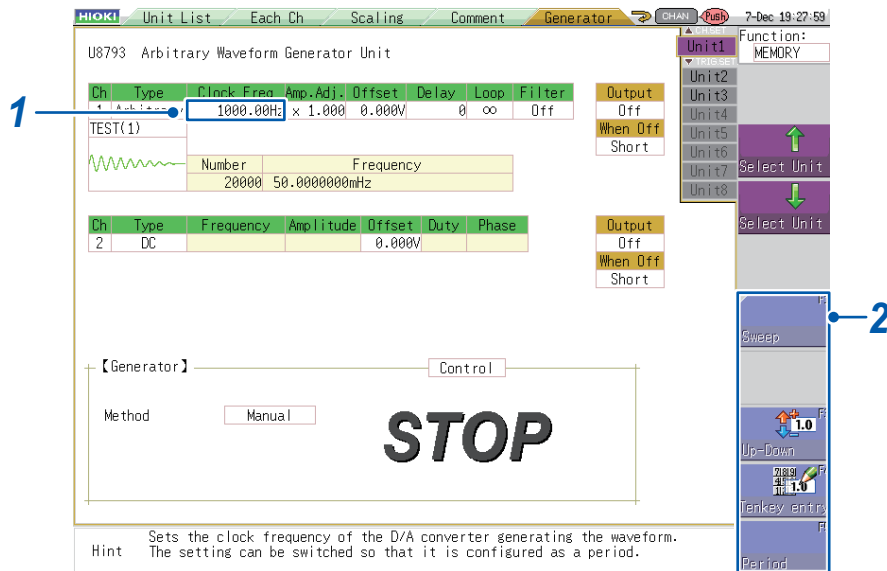

- 1 Select the **[Clock Freq.]** setting.
- 2 Press a function key (**F1** to **F5**) or select a button with the mouse.

Sweep	p.41
Up-Down	p.18
Tenkey entry	p.19
Period	Allows you to enter the setting as a period instead of a frequency. This value can be set only by means of numeric keypad input. (p.19)

- A low clock frequency may result in a stepped output waveform, which can be smoothed by applying a filter. (p.56)

Valid clock frequency setting range: 0 Hz to 2 MHz (in 0.01 Hz increments)

Valid clock period setting range: 0 sec. to 100 sec.

- The clock period can be set as desired within the above range. However, the clock period of the waveform that is actually output will be the clock period of the waveform corresponding to the valid clock frequency setting that would produce the clock period closest to the user-entered clock period value.
- Because the maximum clock frequency that can be set is 2 MHz (clock period: 500 ns), outputting measurement data that was measured at sampling speed of greater than 500 ns/S will cause the frequency of the output waveform to be less than the frequency of the measurement waveform.

## 7.4 Setting Amplitude Adjustment

This section describes how to set the amplitude of the arbitrary waveform being output. The amplitude can be adjusted prior to output, for example when you wish to vary the amplitude minutely. A sweep setting may also be used. (p.41)

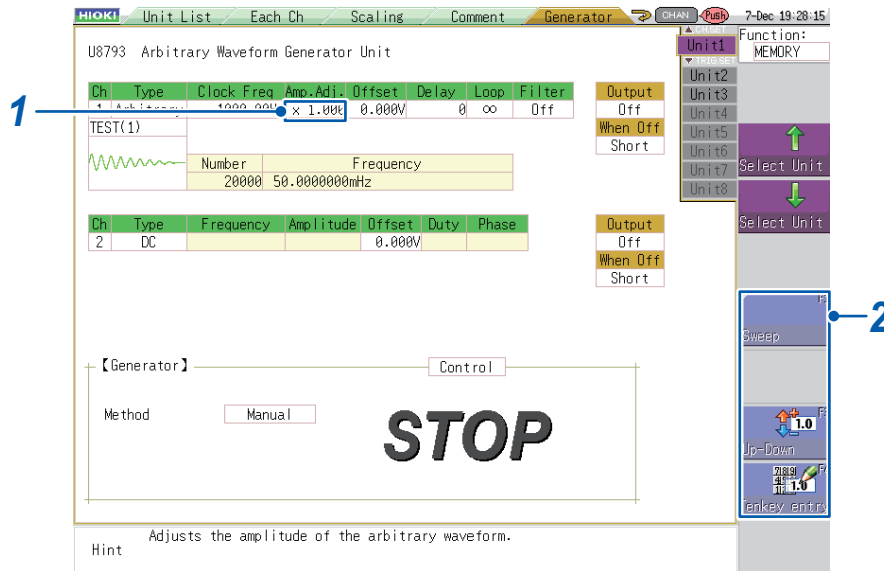

- 1 Select the [Amp Adj] setting.
- 2 Press a function key (F1 to F5) or select a button with the mouse.

Sweep	p.41
Up-Down	p.18
Tenkey entry	p.19

Valid amplitude adjustment setting range:  $\times 0$  to  $\times 2$  (in 0.001 increments)

- For the U8793, accuracy is guaranteed for output voltages within the range of -10 V to +15 V. If the amplitude of the arbitrary waveform to be output is increased using amplitude adjustment so that the range within which accuracy is guaranteed is exceeded, part of the output waveform will be clamped as follows:  
Upper limit of +16 V, lower limit of -11 V

# 7.5 Setting the Offset

This section describes how to set the offset for registered arbitrary waveform data. The offset is added to the arbitrary waveform data before it is output. The sweep setting may also be used. (p.41)

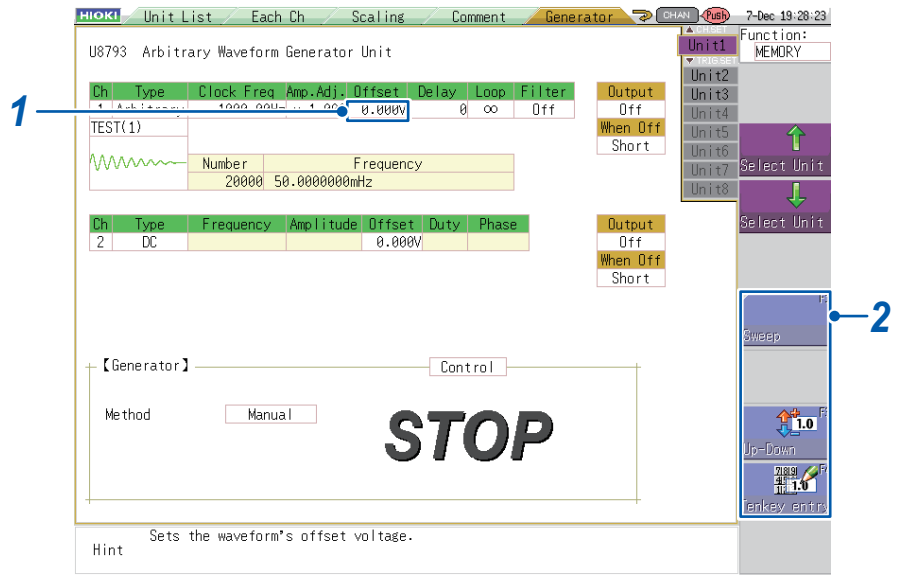

- 1 Select the **[Offset]** setting.
- 2 Press a function key (**F1** to **F5**) or select a button with the mouse.

Sweep	p.41
Up-Down	p.18
Tenkey entry	p.19

Valid offset setting range: -10 V to +15 V (in 1 mV increments)

- For the U8793, accuracy is guaranteed for output voltages within the range of -10 V to +15 V. If the value obtained by adding the arbitrary waveform amplitude and offset exceeds the range within which accuracy is guaranteed, part of the output waveform will be clamped as follows: Upper limit of +16 V, lower limit of -11 V

# 7

## 7.6 Setting the Delay

This section describes how to set the delay (phase) for the arbitrary waveform being output as a data position. Output will start from the set data position.

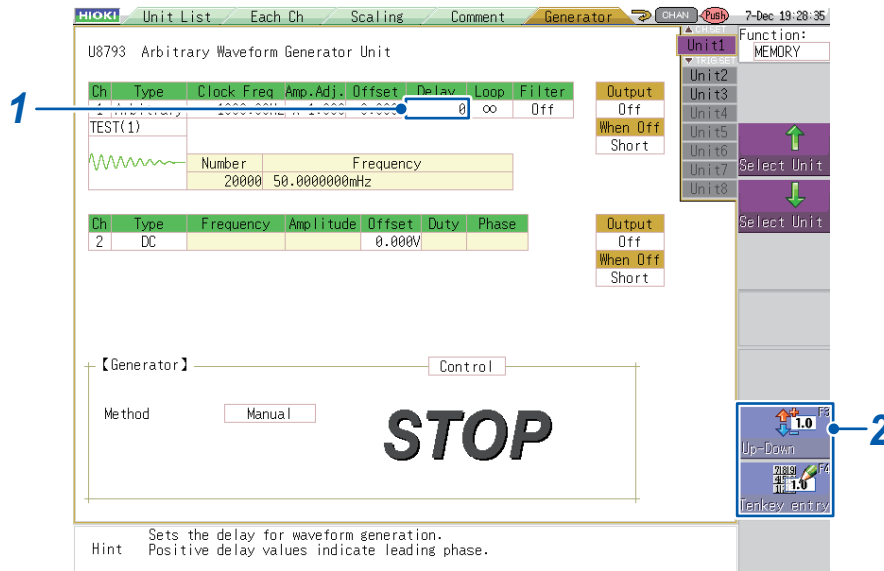

- 1 Select the **[Delay]** setting.
- 2 Press a function key (**F1** to **F5**) or select a button with the mouse.

Up-Down	p. 18
Tenkey entry	p. 19

The delay can be set within the range of -250,000 to 250,000 in increments of 1 data point. Positive delay values indicate leading phase.

Registered arbitrary waveform data

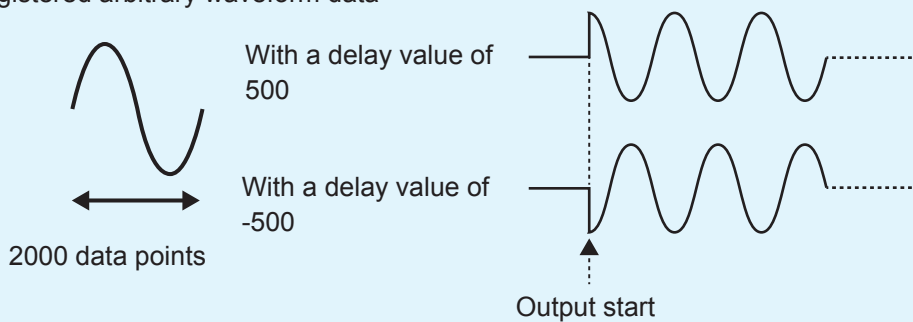

## 7.7 Setting the Number of Loops (When Sweep Is Disabled)

This section describes how to set the number of times to repeat the arbitrary waveform being output. Once output starts, the waveform will be output the set number of times.

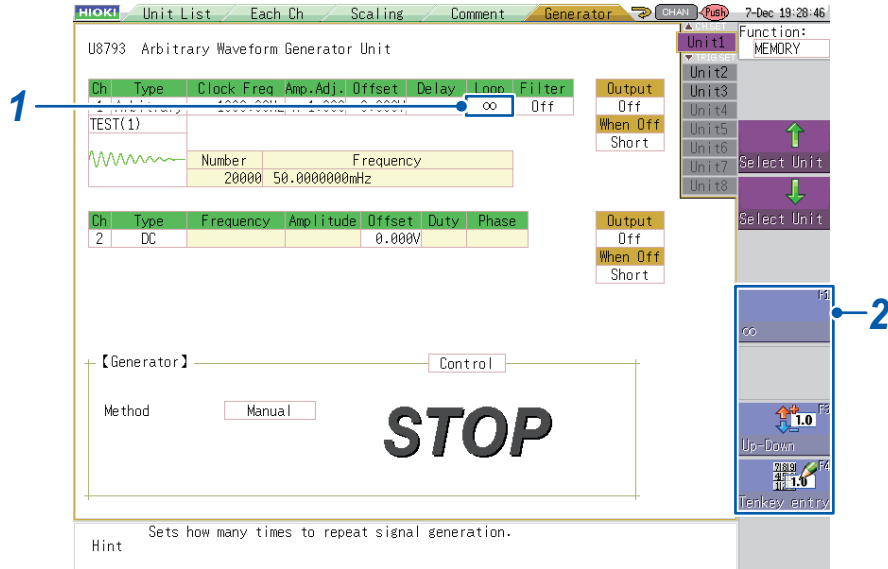

- 1 Select the [Loop] setting.
- 2 Press a function key (F1 to F5) or select a button with the mouse.

∞	Continues to repeat the arbitrary waveform until output is stopped.
Up-Down	p. 18
Tenkey entry	p. 19

- Valid number of loops setting range: 1 to 50,000
- After the waveform is output the set number of times, a 0 V signal will be output.
- If the clock frequency, amplitude adjustment, or offset is set to sweep, the number of loops setting cannot be configured.
- If a delay has been set, the repeat output waveform will be generated as follows:

2000 data points

Output settings  
Delay: 500  
Number of loops: 5

Start of output

## 7.8 Setting the Filter

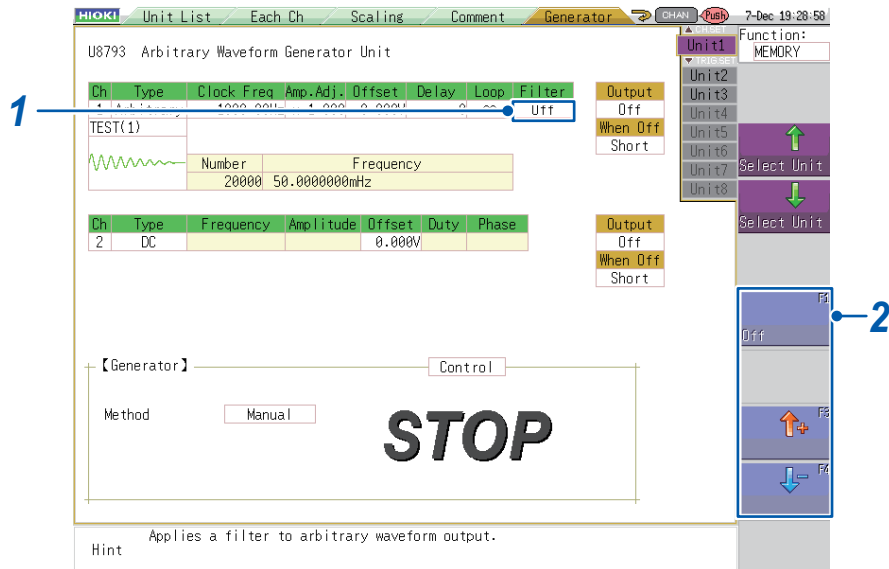

- 1 Select the **[Filter]** setting.
- 2 Press a function key (**F1** to **F5**) or select **[Off]** with the mouse.

**OFF** (default value), **50 Hz**, **100 Hz**, **200 Hz**, **500 Hz**, **1 kHz**, **2 kHz**, **5 kHz**, **10 kHz**, **20 kHz**, **50 kHz**, **100 kHz**, **200 kHz**, **500 kHz**, **1 MHz**

- The unit provides a two-stage low-pass filter.
- The tighter the set filter (i.e., the lower the cutoff frequency), the smaller the amplitude of the waveform that is actually output will be compared to the arbitrary waveform data's amplitude value.
- The filter setting is not available when Generator Control (p.71) is set to **[RUN]** or **[PAUSE]**.

## 7.9 Setting the Output to ON or OFF

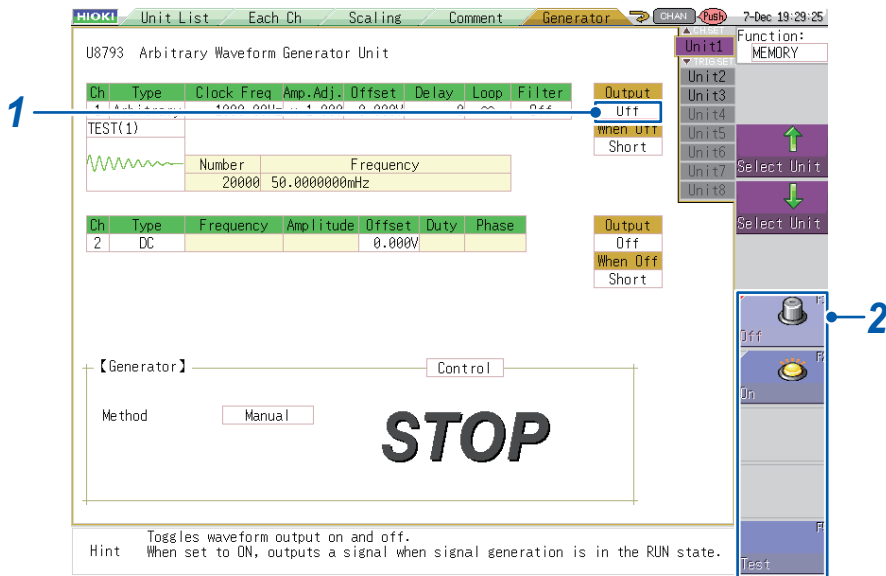

- 1 Select the **[Output]** setting.
- 2 Press a function key (**F1** to **F5**) or select a button with the mouse.

Off	Does not output the arbitrary waveform, regardless of the state of Generator Control (p.71). (Output indicator: Off)
On	Outputs the set arbitrary waveform when Generator Control (p.71) is <b>[RUN]</b> . (Output indicator: Red)
Test	Generates the set test output. (Output indicator: Red)

### After selecting **[Test]**

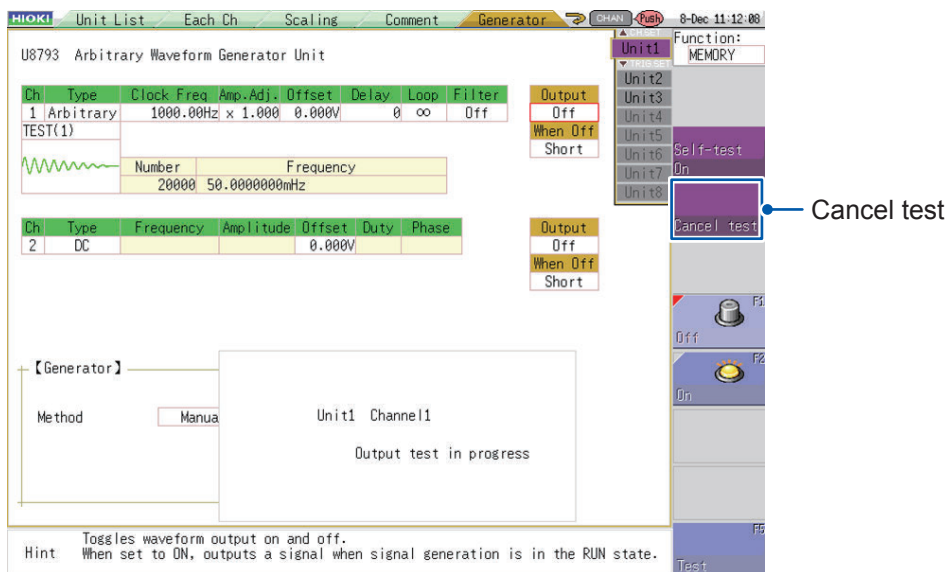

Pressing **(TRIG.SET)** (**TRIG.SET**) will stop test output.

This test mode does not provide functionality for judging test results with the unit. You are responsible for determining whether the set arbitrary waveform is being properly output during the output test.

# 7.10 Setting Behavior When Output is OFF

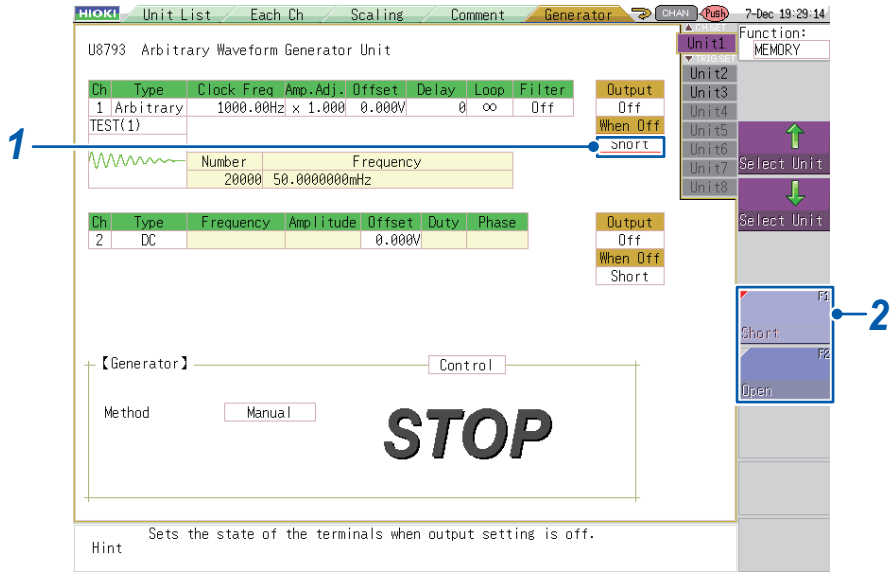

- 1 Select the **[When Off]** setting.
- 2 Press a function key (**F1** to **F5**) or select a button with the mouse.

Short	<p>When the output (p.57) is OFF, places the output terminal in a shorted state by separating it from the unit's internal circuitry and introducing resistance.</p>
Open	<p>When the output (p.57) is OFF, places the output terminal in an open state by separating it from the unit's internal circuitry.</p>

# 8

## Program Settings (U8793)

This section describes the settings that are available when an U8793 Arbitrary Waveform Generator Unit is selected on the Generator screen (signal generation settings screen) (p. 15) and the waveform type is set to **[Program]**.

The program function can be used to output waveforms by combining up to 128 steps. An FG waveform, arbitrary waveform, or sweep waveform can be specified for each step.

### 8.1 Switching to the Program Settings Screen

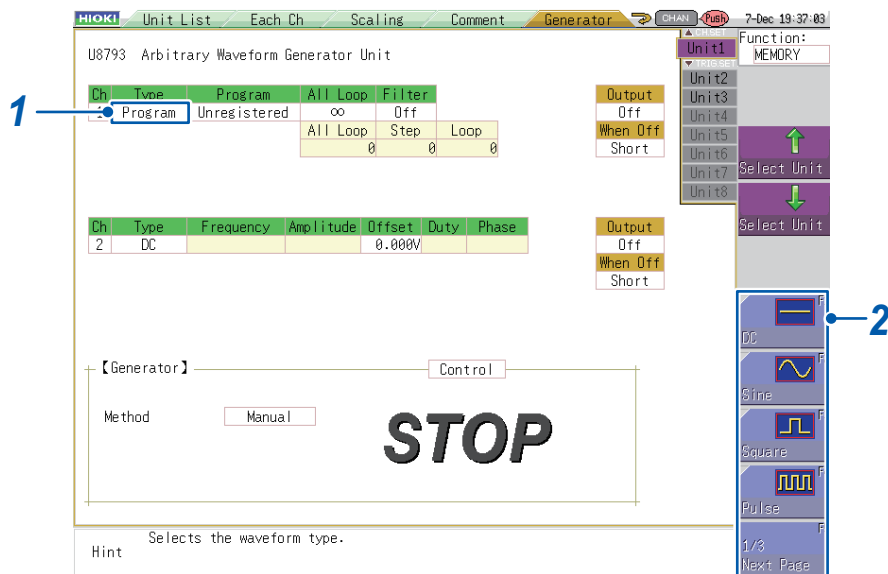

- 1 Select the **[Type]** setting.
- 2 Press a function key (**F1** to **F5**) or select **[Program]** (3/3 pages) with the mouse.

## 8.2 Editing the Program

### Opening the Edit screen

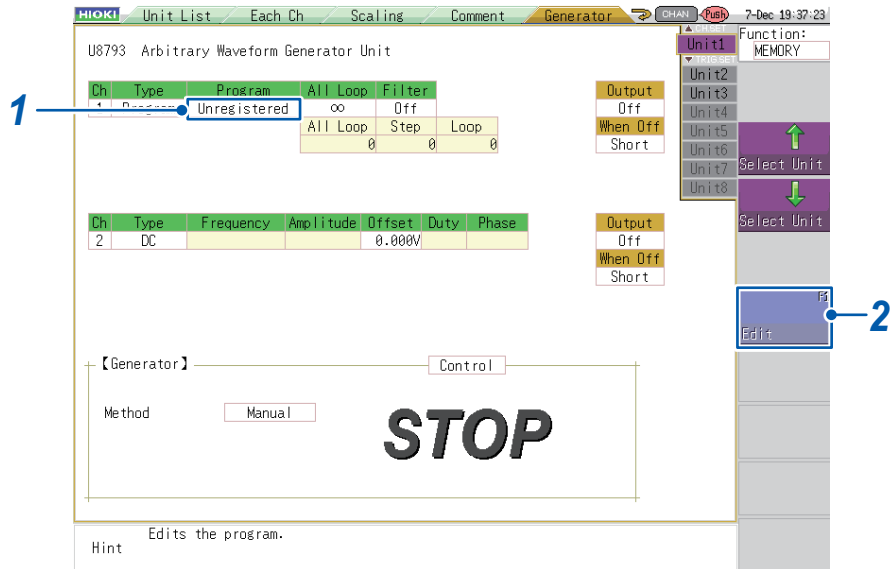

- 1 Select the **[Program]** setting.
- 2 Press the function key (**F1**) or select **[Edit]** with the mouse.  
(A setting screen will be displayed for each step.)

## Configuring each step

A program can consist of up to 128 steps.

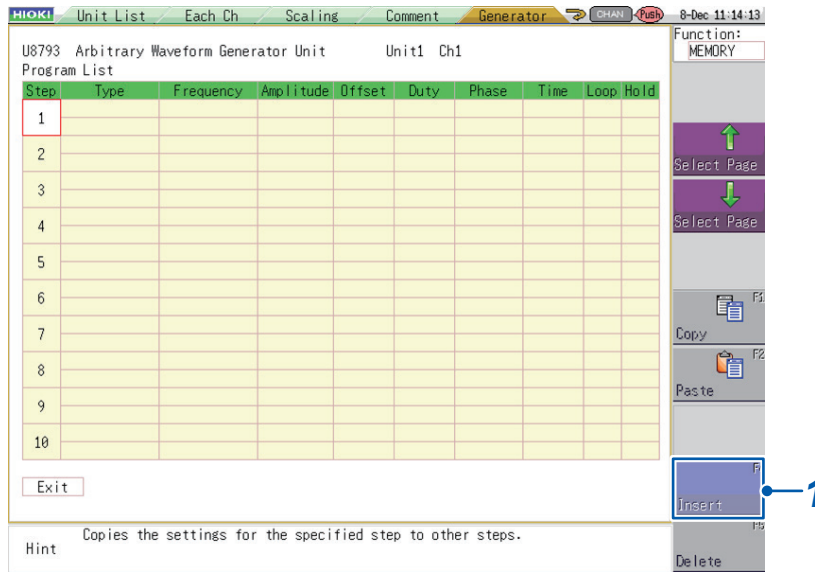

- 1 Press the function key (**F4**) or select **[Insert]** with the mouse. (You will be able to edit Step 1.)

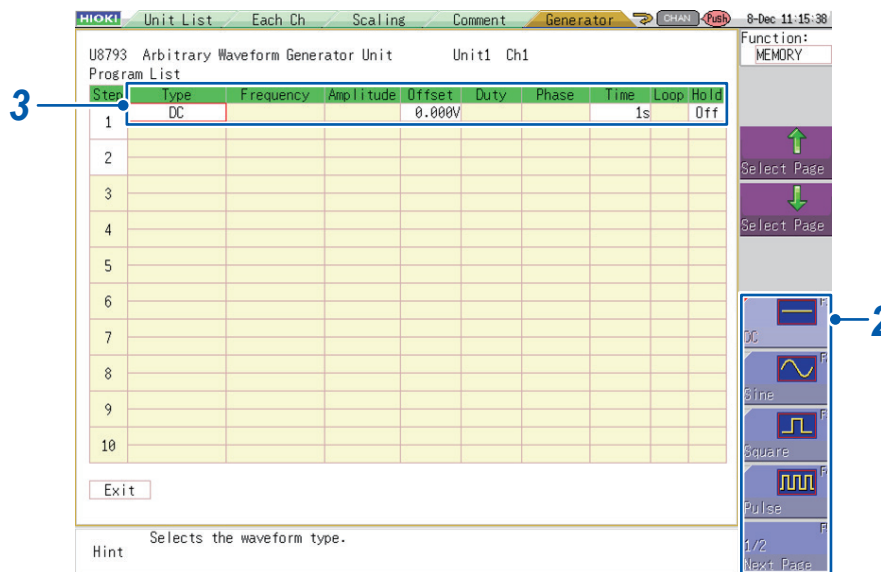

- 2 Press a function key (**F1** to **F5**) or select a waveform type with the mouse.
- 3 Set the parameters for the waveform you selected.

Type	Selects the waveform type. (p.20)
Frequency	Sets the frequency. (p.21)
Amplitude	Sets the amplitude. (p.22)
Offset	Sets the offset. (p.23)
Duty	Sets the duty. (This setting is available only when a pulse waveform is selected.) (p.24)
Phase	Sets the phase at the start of output. (This setting is available only when a waveform other than a DC or arbitrary waveform is selected.) (p.25)
Time	Sets the time at which to output each step's waveform. When using the sweep setting, sets the sweep time.
Loop	Sets the number of times to repeat the sweep waveform. The valid setting range is 1 to 1000. (This setting is available only when using the sweep setting.)
Hold	Sets the processing to perform at the end of each step. To maintain the end state of each step after that step completes instead of moving on to the next step, set this parameter to ON. When set to OFF, the program will proceed to the next step.

- 4 To edit Step 2 after you have finished editing Step 1, move the cursor to the Step 2 position and press the function key (**F4**) or select **[Insert]** with the mouse. Repeat this process for each step in order. To edit Step 11 and subsequent steps, press **(TRIG.SET)** (**TRIG.SET**) to display the editing screen for those steps.

- To delete a step, move the cursor to the step number you wish to delete and press the function key (**F5**) or select **[Delete]** with the mouse.
- You can use copy and paste to copy the settings of one step to another step. (p.16)
- The start and end values for the sweep setting are displayed on the upper and lower rows. The sweep time controls how long the sweep operation lasts.

**When using the sweep setting for an FG waveform**

**When using the sweep setting for a user waveform**

## Ending program editing



- 1 Select the **[Exit]** setting.
- 2 Press a function key (**F1** to **F5**) or select a button with the mouse.

Save	Saves the edited program and exits.
Close	Exits without saving the edited program.

### Hold setting operation

- While the hold function is in effect, HIGH-level output will be generated from the external control terminal's OUT pin (p. 14, p.83)
- When the hold parameter for a step is set to **[On]**, the waveform set by the that step will be output until the hold is canceled.
- When a step for which the hold parameter is set to **[On]** contains a sweep waveform, the waveform defined by the end value for each sweep parameter will be output after repeating the sweep waveform the set number of loops, and that output will continue until the hold state is canceled.

### Sweep waveform setting

Example

The waveform defined by the sweep end values will be output while the hold function is in effect.

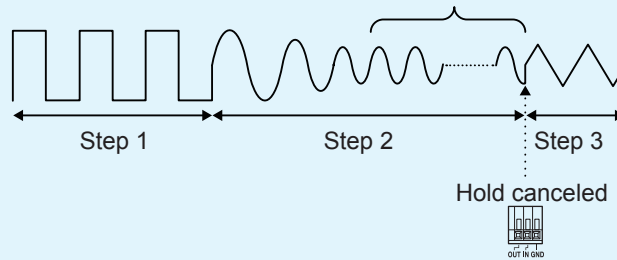

A LOW-level signal is input to the IN external control terminal.

- To cancel the hold state, input a LOW-level signal to the unit's IN external control terminal. It takes about 100  $\mu$ s to cancel the hold from the time a LOW-level signal is inputted. (p. 14, p.82)

### Switching steps

- It takes approximately 20  $\mu$ s to switch to the next step once the previous step ends. The output voltage during that interval will be the voltage at the time the previous step completed.

# 8.3 Setting the Overall Number of Loops

This section describes how to set the number of times to execute the edited program.

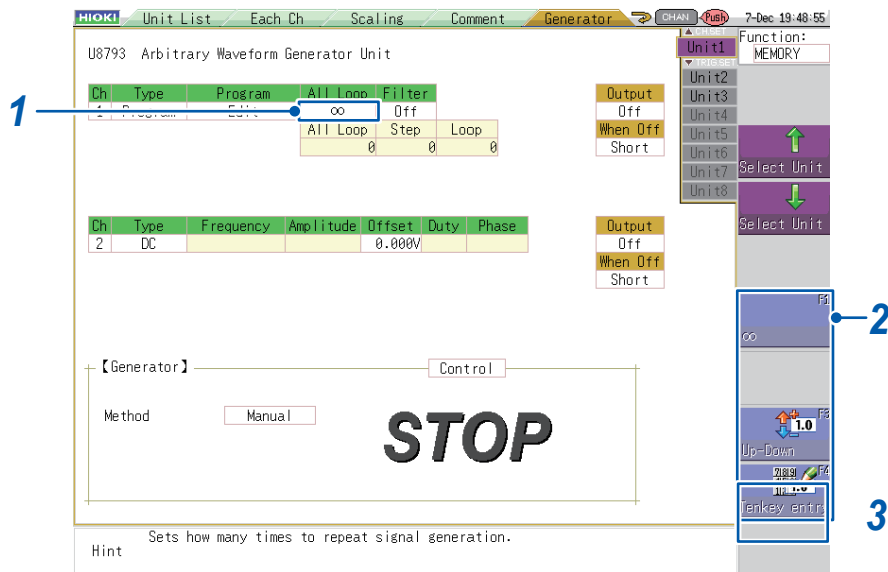

- 1 Select the **[All Loop]** setting.
- 2 Press a function key (**F1** to **F5**) or select a button with the mouse.

∞	Continues to repeat the program waveform until output is stopped.
Up-Down	p. 18
Tenkey entry	p. 19

Valid overall number of loops setting range: 1 to 50,000

When the overall number of loops has been set, approximately 20 μs will elapse from the time program execution completes until the instrument transitions to the next program execution. The output voltage during that interval will be 0 V.

## 8.4 Setting the Filter

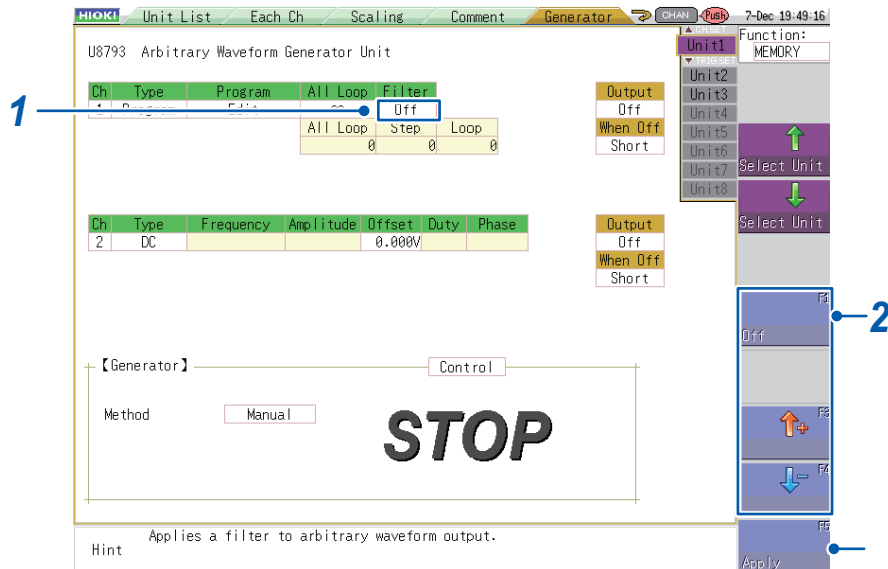

- 1 Select the **[Filter]** setting.
- 2 Press a function key (**F1 to F5**) or select **[Off]** with the mouse.

**OFF** (default value), **50 Hz**, **100 Hz**, **200 Hz**, **500 Hz**, **1 kHz**, **2 kHz**, **5 kHz**, **10 kHz**, **20 kHz**, **50 kHz**, **100 kHz**, **200 kHz**, **500 kHz**, **1 MHz**

- 3 Press the function key (**F5**) or select **[Apply]** with the mouse.  
(The set cutoff frequency will be enabled.)

- The unit provides a two-stage low-pass filter.
- The filter is enabled only for arbitrary waveforms to which program steps have been set.
- The tighter the set filter (i.e., the lower the cutoff frequency), the smaller the amplitude of the waveform that is actually output will be compared to the arbitrary waveform data's amplitude value.
- The filter setting is not available when Generator Control (p.71) is set to **[RUN]** or **[PAUSE]**.
- When changing the filter setting, press **[Apply]**. The filter setting will not take effect unless you do so.

## 8.5 Saving the Edited Program

This section describes how to save the edited program as a file.

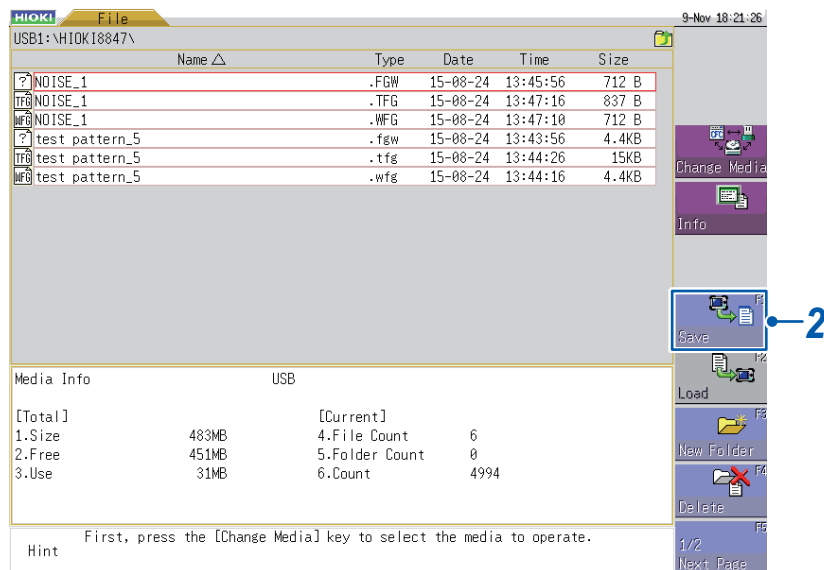

- 1 Press **FILE** (**FILE**).
- 2 Press the function key (**F1**) or select **[Save]** (1/2 pages) with the mouse.

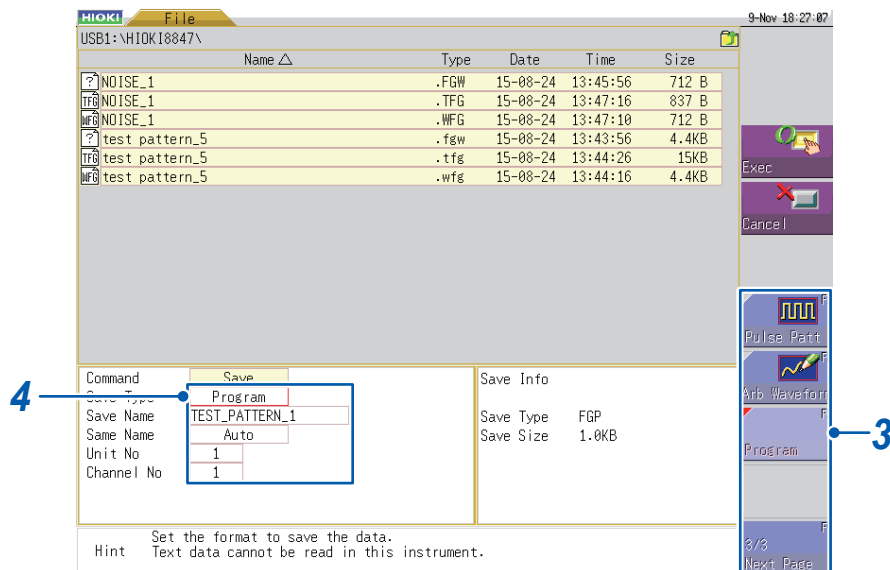

- 3 Press a function key (**F1** to **F5**) or select **[Program]** (3/3 pages) with the mouse.
- 4 Set the information to save with a function key (**F1** to **F5**) or the mouse.

Save Name	Allows you to enter the program name.
Same Name	Sets the processing to perform if a file with the same name exists in the save folder.
Unit No.	Sets the U8793 unit number to which the program being saved has been registered.
Channel No.	Sets the U8793 channel number to which the program being saved has been registered.

- 5 Press **CH.SET** (**CH.SET**).  
(The program will be saved as a file with the extension ".fgp.")

## 8.6 Checking Program Progress

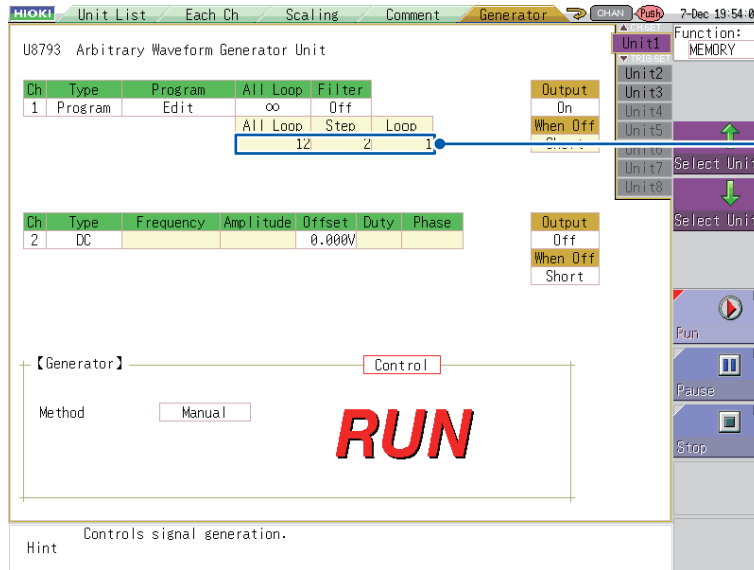

Number of loops and steps completed and total number of loops

You can check the number loops and steps completed and the total number of loops.

When the total number of loops is set to ∞, the total number of loops display will be fixed to [∞] if more than 50,000 loops have been completed.

# 9

# Outputting Signals

## 9.1 Setting the Control Method

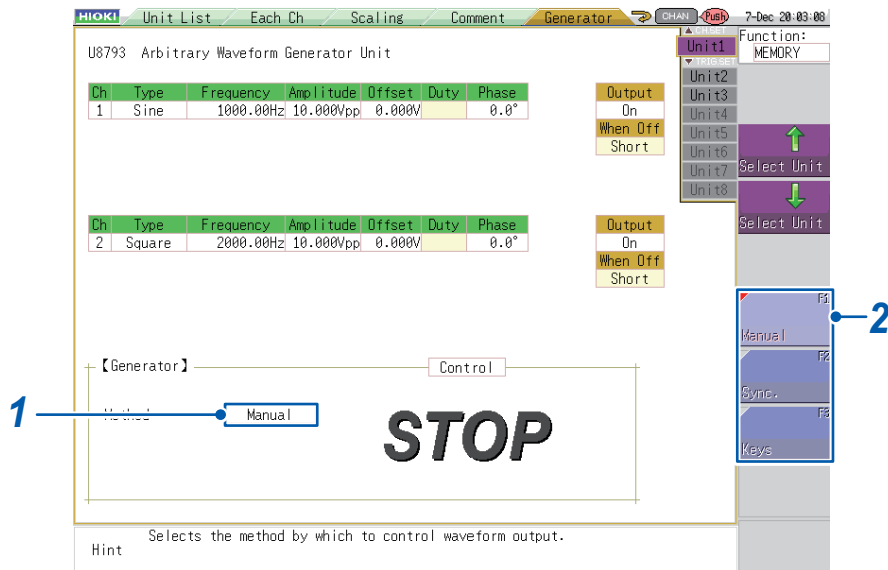

- 1 Select the **[Method]** setting.
- 2 Press a function key (**F1** to **F5**) or select a button with the mouse.

Manual	Restricts control of signal output to this Generator screen (signal generation settings screen).
Sync.	Augments manual control with signal output in synchronization with the start and end of measurement. <div style="display: flex; align-items: center; margin-bottom: 10px;"> <span><b>(START)</b>: Starts output when measurement starts.</span> </div> <div style="display: flex; align-items: center;"> <span><b>(STOP)</b>: Stops output when measurement stops.</span> </div>
Keys	Augments manual control by allowing signal output to be manipulated using the Memory HiCorder's keys. <div style="display: flex; align-items: center; margin-bottom: 10px;"> <span><b>(START)</b>: Starts output.</span> </div> <div style="display: flex; align-items: center; margin-bottom: 10px;"> <span><b>(STOP)</b>: Stops output.</span> </div> <div style="display: flex; align-items: center; margin-bottom: 10px;"> <span>: Pauses output.</span> </div> <p>Since this screen is dedicated to use by the output function, the  <b>(START)</b> and  <b>(STOP)</b> keys cannot be used to start or stop measurement.</p>

When the control method is **[Sync.]**, output will start approximately 3 ms before the start of measurement.

## 9.2 Setting Output When Measurement Completes

This setting is available after selecting **[Sync.]**.

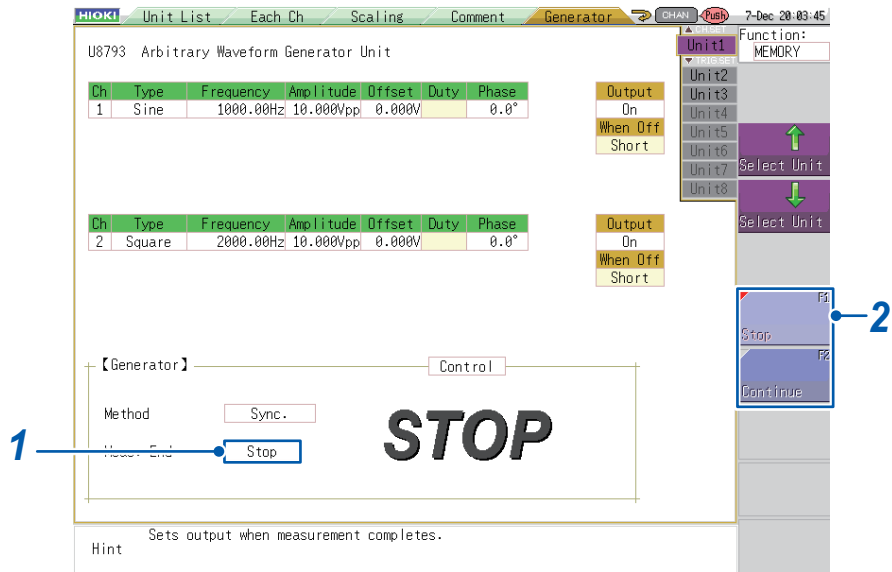

- 1** Select the **[Meas. End]** setting.
- 2** Press a function key (**F1** to **F5**) or select a button with the mouse.

Stop	Stops output when measurement completes.
Continue	Continues output even when measurement completes.

# 9.3 Controlling Signal Output

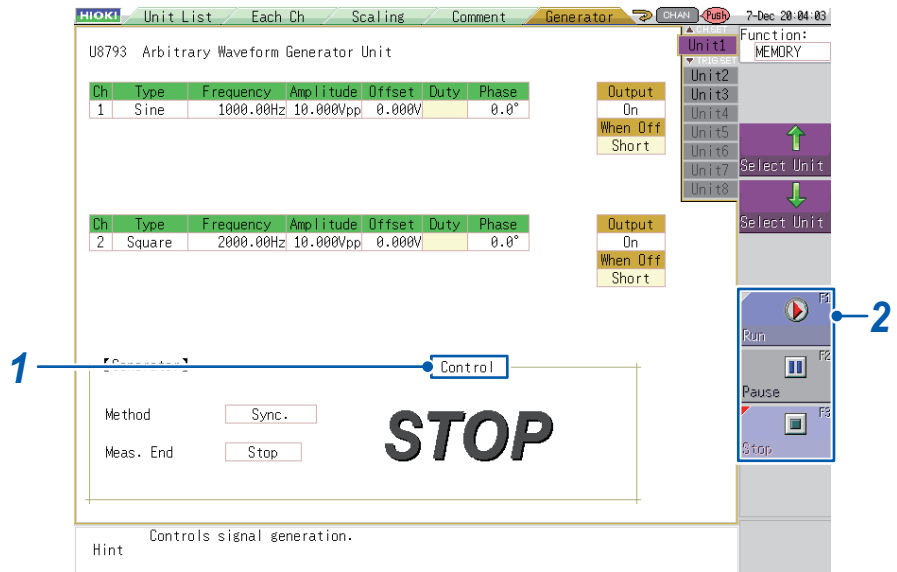

- 1 Select the **[Control]** setting.
- 2 Press a function key (**F1** to **F5**) or select a button with the mouse.

Run	Starts output. (Output indicator: Red)
Pause	Pauses output. While output is paused, the output at the time <b>[PAUSE]</b> was pressed will be output. (Output indicator: Red)
Stop	Stops output. (Output indicator: Off)

The current output status is displayed underneath the **[Control]** setting.

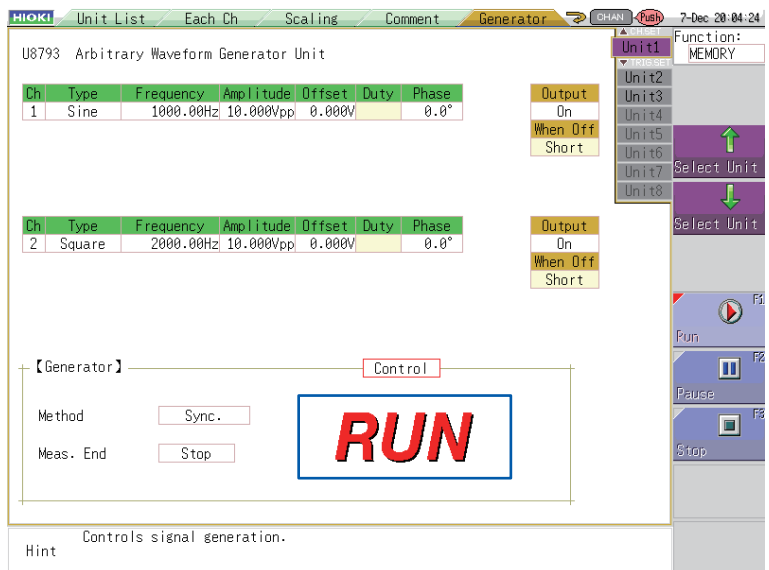

- Pressing **[RUN]** or **[STOP]** may cause the output waveform to exhibit undershoot or overshoot.
- When control is set to **[RUN]** or **[PAUSE]**:
  - U8793: The type of waveform being output cannot be changed. The parameters for the selected waveform type can be changed. (However, the parameters cannot be changed if any parameter has been set to “sweep.”)
  - MR8790: The type of waveform being output as well as associated parameter settings can be changed.
  - MR8791: The output mode cannot be changed. Associated parameter settings can be changed.
- When **[PAUSE]** is pressed, the unit will continue to output the voltage at the time **[PAUSE]** was pressed. Subsequently, pressing **[RUN]** will cause output to resume from the phase at the time that **[PAUSE]** was pressed.

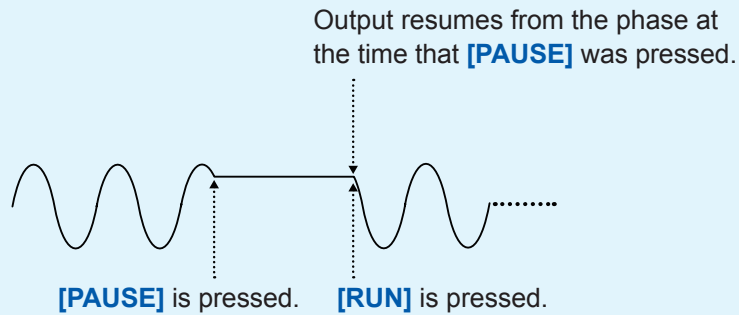

- While in the **[PAUSE]** state, HIGH-level output will be generated from the external control terminal's OUT pin (p. 14, p. 83).
- When output (p. 25, p. 33, p. 57) is set to OFF while in the **[PAUSE]** state:
  - U8793: Output will be 0 V. When output is turned back on, output will remain 0 V.
  - M8790: Output will be 0 V. When output is turned back on, output will return to the voltage in effect while in the **[PAUSE]** state.
  - MR8791: When operating in pulse mode, output will be LOW-level. When output is turned back on, output will remain LOW-level.
- When in pattern mode, output will be at the same level as the first pattern. When output is turned back on, output will remain at the same level as the first pattern.
- When control is set to **[RUN]** or **[PAUSE]**, output can be turned on and off (p. 27, p. 33, p. 39, p. 57), but there may be a disturbance in the waveform when output is turned on or off due to the output relay's response.

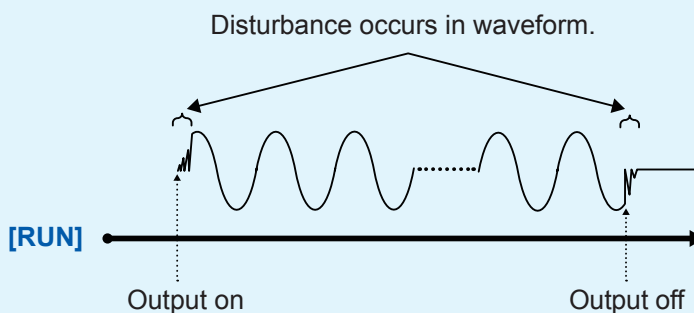

- After turning output on, no disturbance will occur in the waveform when setting control to **[RUN]** or **[STOP]**.

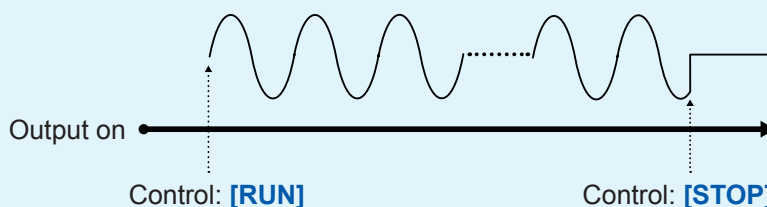

# 10

## Configuring Settings on the Waveform Screen

### 10.1 Setting Output Waveform Parameters

Parameters (frequency, amplitude, and offset) for the output waveform that was configured on the Generator screen (signal generation setting screen) (p. 15) can be changed on the Waveform screen. The ability to configure and change these settings while outputting and measuring the resulting waveform provides a convenient way to measure a waveform while varying its parameters.

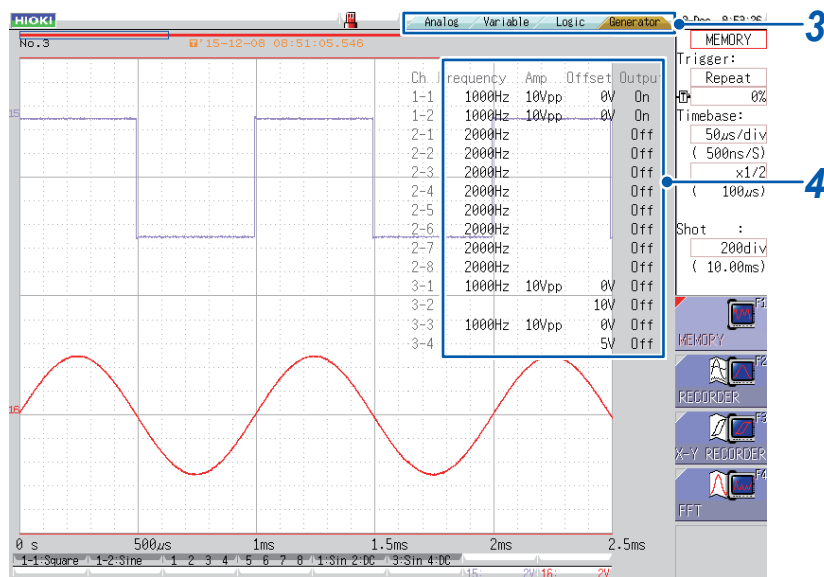

- 1 Display the Waveform screen (if viewing another screen, press **DISP** (**DISP**) to display the Waveform screen).
- 2 Press **CH.SET** (**CH.SET**) (to display the tabs).
- 3 Press **CH.SET** (**CH.SET**) or select the **[Generator]** tab with the mouse.
- 4 Set the following parameters as desired.

Frequency	Sets the frequency. (p.21)
Amp	Sets the amplitude. (p.22)
Offset	Sets the offset. (p.23)
Output	Turns output on or off. (p.27)

## To display the waveform and output parameter settings in separate windows

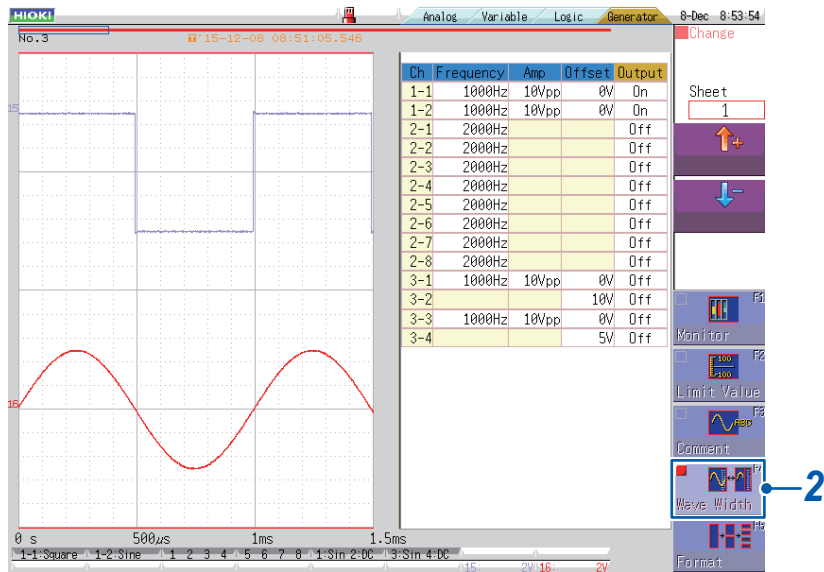

- 1 Press **DISP** (**DISP**) (to show the display menu on the right side of the screen).
- 2 Press the function key (**F4**) or select **[Wave Width]** with the mouse.

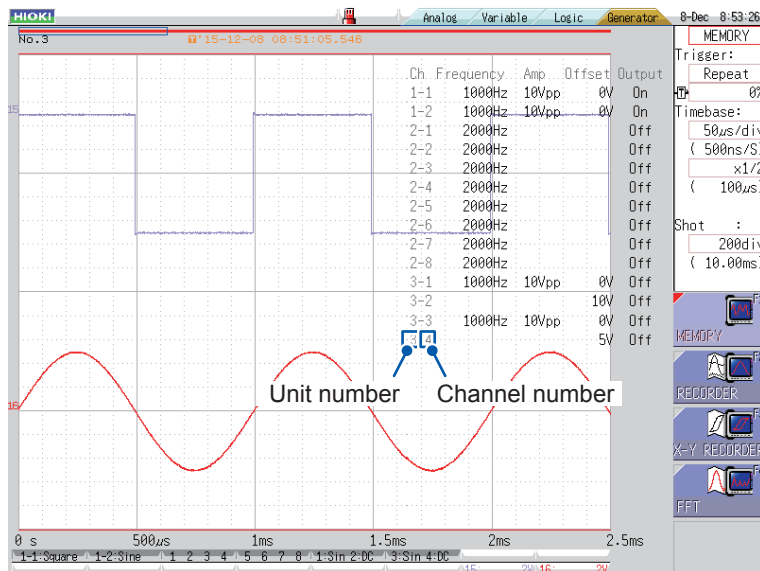

- 3 Press **DISP** (**DISP**) twice (so that you can move the cursor to the output parameter settings).

- In addition to turning output on or off, you can set the frequency, amplitude, and offset (or output DC voltage when the waveform type is DC). When the waveform type is arbitrary waveform, you can set the clock frequency, amplitude adjustment, and offset.
- Only the integer portion of the frequency, amplitude, and offset settings is shown. Even if a setting has a decimal portion, it will be rounded to the nearest whole number for display purposes. (Although each setting is shown as an integer, its decimal portion remains valid.)
- Even if output is set to ON, the waveform will not be output unless generator control (p. 71) (p.75) is set to **[RUN]**. Set Generator Control to **[RUN]** in advance on the Generator screen.
- Depending on the waveform type, the output parameter settings will be shown as follows:

**U8793**

	Ch	Frequency	Amp	Offset	Output
When set to DC	1-1			15V	0n
When set to FG Wave	1-2	1000Hz	10Vpp	0V	0n

	Ch	Frequency	Amp	Offset	Output
When set to Arb. Wave	1-1	1000Hz	x1.000	0V	0n
When set to Program	1-2	Program			0n

	Ch	Frequency	Amp	Offset	Output
When set to sweep	1-1	Sweep			0n
	1-2			15V	0n

**MR8790**

	Ch	Frequency	Amp	Offset	Output
When set to DC	1-1			10V	0n
When set to Sine Wave	1-2	1000Hz	10Vpp	0V	0n
When set to DC	1-3			5V	0n
When set to Sine Wave	1-4	10000Hz	10Vpp	0V	0n

**MR8791**

Output mode: Pulse

Ch	Frequency	Amp	Offset	Output
1-1	10000Hz			0n
1-2	10000Hz			0n
1-3	10000Hz			0n
1-4	10000Hz			0n
1-5	10000Hz			0n
1-6	10000Hz			0n
1-7	10000Hz			0n
1-8	10000Hz			0n

Output mode: Pattern

Ch	Frequency	Amp	Offset	Output
1	10000Hz			0n

# 10.2 Waveform Type and Output Status Display

The output waveform type and output status are shown on the bottom of the Waveform screen.

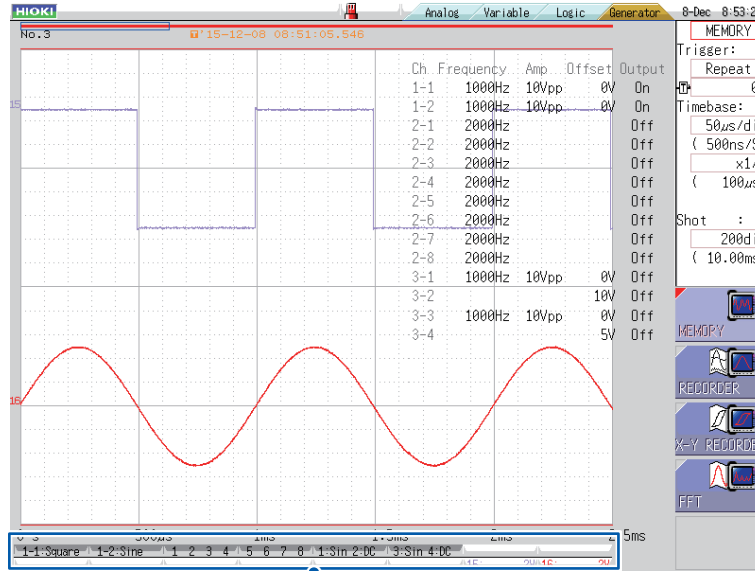

Waveform type and output status display

### Unit display positions

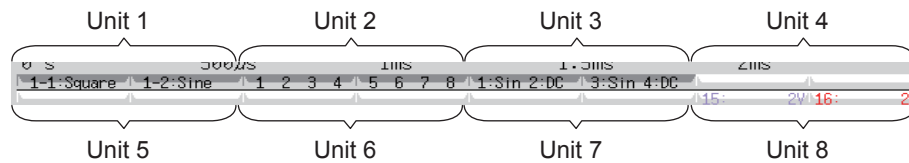

### Status display

Output inactive	Output active
1-1: Square   1-2: Sine	1-1: Square   1-2: Sine (Red background)

### Waveform type display

U8793 (2ch/unit)	<table border="0"> <tr> <td>1-1: DC DC</td> <td>1-2: Sine Sine</td> <td>1-1: Square Square</td> <td>1-2: Pulse Pulse</td> </tr> <tr> <td>1-1: Tri Triangle</td> <td>1-2: Ramp-up Ramp-up</td> <td>1-1: Ramp-dn Ramp-down</td> <td>1-2: TEST(1) Arbitrary (Filename display Uppercase: 3 letters Lowercase: 7 letters)</td> </tr> <tr> <td colspan="2">1-1: Program Program</td> <td colspan="2">1-2: DC</td> </tr> </table>	1-1: DC DC	1-2: Sine Sine	1-1: Square Square	1-2: Pulse Pulse	1-1: Tri Triangle	1-2: Ramp-up Ramp-up	1-1: Ramp-dn Ramp-down	1-2: TEST(1) Arbitrary (Filename display Uppercase: 3 letters Lowercase: 7 letters)	1-1: Program Program		1-2: DC	
1-1: DC DC	1-2: Sine Sine	1-1: Square Square	1-2: Pulse Pulse										
1-1: Tri Triangle	1-2: Ramp-up Ramp-up	1-1: Ramp-dn Ramp-down	1-2: TEST(1) Arbitrary (Filename display Uppercase: 3 letters Lowercase: 7 letters)										
1-1: Program Program		1-2: DC											
MR8790 (4ch/unit)	<table border="0"> <tr> <td>1: Sin Sine</td> <td>2: DC DC</td> <td>3: Sin</td> <td>4: DC</td> </tr> </table>	1: Sin Sine	2: DC DC	3: Sin	4: DC								
1: Sin Sine	2: DC DC	3: Sin	4: DC										
MR8791 (8ch/unit)	<table border="0"> <tr> <td>1</td><td>2</td><td>3</td><td>4</td><td>5</td><td>6</td><td>7</td><td>8</td> </tr> </table>	1	2	3	4	5	6	7	8				
1	2	3	4	5	6	7	8						

# 11

# Self-test Function

## 11.1 Monitoring Output Values with Test Output

# 11

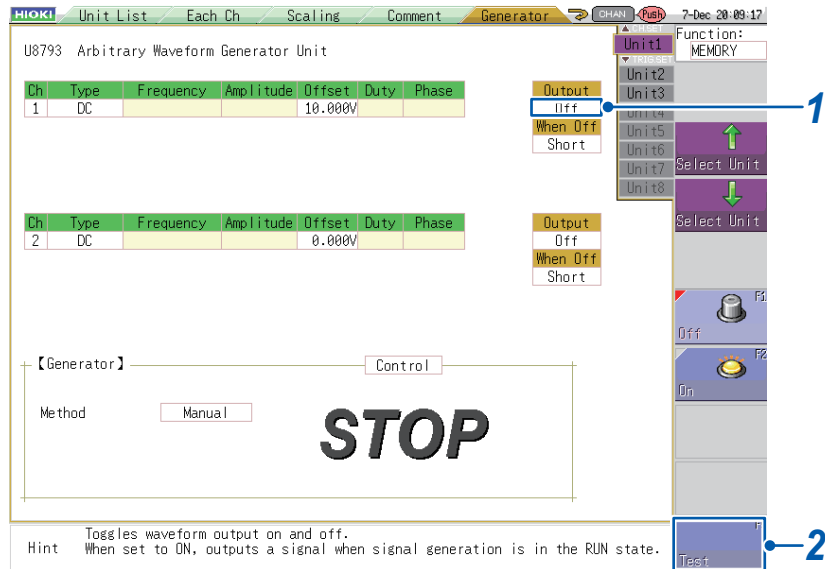

- 1 Select the **[Output]** setting.
- 2 Press a function key (**F5**) or select **[Test]** with the mouse.

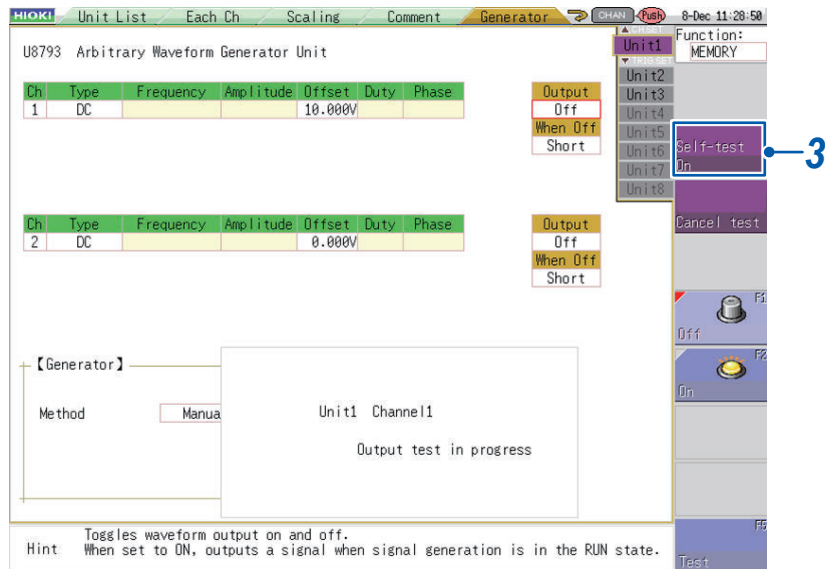

- 3 Press  (**CH.SET**) (to display monitor values).

**U8793**

U8793 Arbitrary Waveform Generator Unit

Ch	Type	Frequency	Amplitude	Offset	Duty	Phase
1	DC		10.000V			
2	DC		0.000V			

Output test in progress  
Voltage: 10.01 V

Hint: Toggles waveform output on and off. When set to ON, outputs a signal when signal generation is in the RUN state.

The output voltage monitor value will be displayed.

**MR8790**

MR8790 Wave Generator Unit

Ch	Type	Frequency	Amplitude	Offset	Output	When Off
1	DC		0.000V		Off	Short
2	DC		10.000V		Off	Short
3	DC		0.000V		Off	Short
4	DC		0.000V		Off	Short

Output test in progress  
Voltage: 10.01 V  
Current: 2.56mA

Hint: Toggles waveform output on and off. When set to ON, outputs a signal when signal generation is in the RUN state.

The output voltage and output current monitor values will be displayed.

**MR8791**

**Output mode: Pulse**

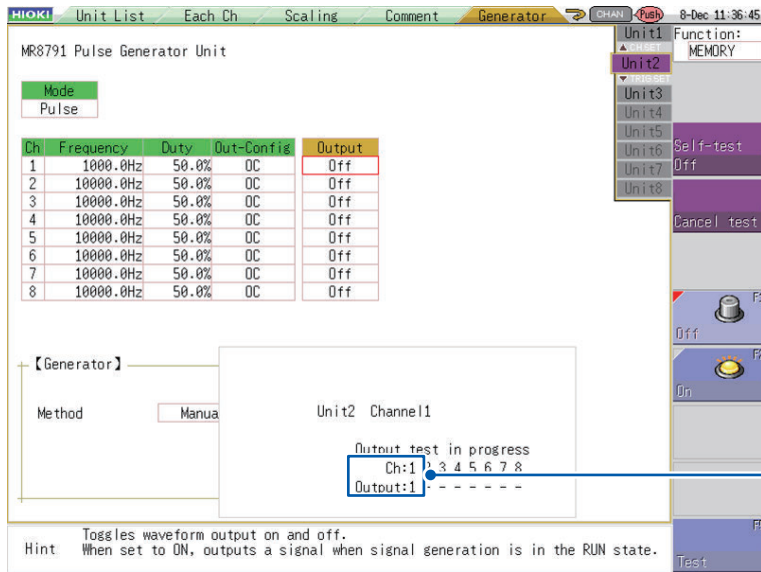

The pulse monitor value will be displayed (1: HIGH level; 0: LOW level).

**Output mode: Pattern**

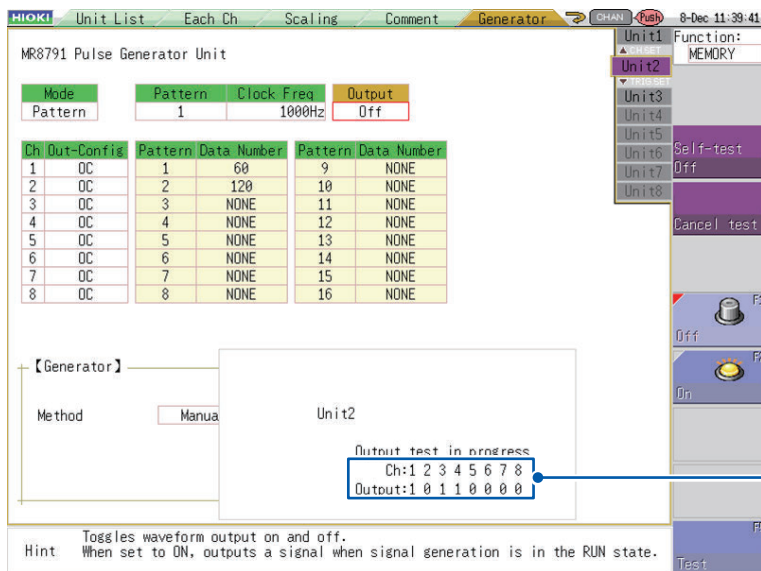

Monitor values for all channels will be displayed (1: HIGH level; 0: LOW level).

To toggle the display of monitor values, press **CH.SET** (**CH.SET**) again.

Press **TRIG.SET** (**TRIG.SET**) to end test output.

- Monitor values using test output cannot be displayed when Generator Control is set to **[RUN]** or **[PAUSE]**.
- A waveform will be output from the output terminal during test output.
- Pressing **CH.SET** (**CH.SET**) will toggle the display of monitor values on and off.



# 12

## External Output Terminal (U8793)

### DANGER

To avoid electrical hazards and damage to the unit, do not apply voltage exceeding the rated maximum to the input terminals.



	I/O terminal	Maximum input voltage
U8793	IN	-0.5 to 7 V DC
	OUT	30 V DC/50 mA

### WARNING

To avoid electric shock or damage to the equipment, always observe the following precautions when connecting to external terminals or connectors:



- Always turn off the power to the unit and to any devices to be connected before making connections.
- Be careful to avoid exceeding the ratings of external terminals and connectors.
- Ensure that devices and systems to be connected to the external control terminals / EXT I/O terminals/ signal input/output terminals are properly isolated.

### CAUTION



Use a common ground for both the external control terminal and the connected equipment. Using different ground circuits will result in a potential difference between the external control terminal's ground and the connected equipment's ground. If the cable or cord is connected while such a potential difference exists, it may result in equipment malfunction or failure.

# 12.1 External Input

Inputting a LOW-level signal from an external device cancels hold operation if the program function is being used and transitions to the next step.

### Signal input method

- 1 Wire the IN and GND pins to the external signal sources.  
See “Connecting Wires to the External Control Terminals (U8793)” (p. 14).
- 2 Short the IN and GND pins or input a HIGH-level (3.5 V to 5.0 V) and LOW-level (0 V to 0.8 V) pulse wave or rectangular wave to the pins.  
The hold will be canceled at the input waveform’s LOW level, and the program will transition to the next step.

Input voltage range	HIGH level: 3.5 V to 5.0 V; LOW level: 0 V to 0.8 V
Pulse width	LOW level: 100 $\mu$ s or greater
Maximum input voltage	-0.5 V to 7 V

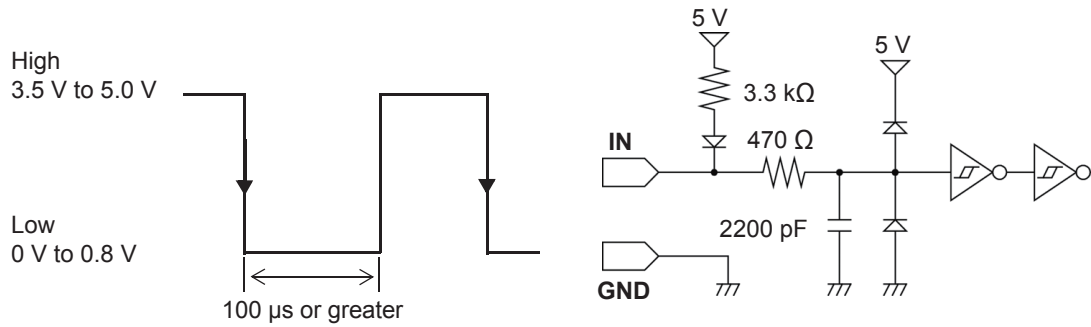

## 12.2 External Output

This section describes how to output a LOW-level signal during waveform output.

### Signal output method

- 1 Wire the OUT and GND pins to the device being controlled.  
See "Connecting Wires to the External Control Terminals (U8793)" (p.14).
- 2 The unit will output a LOW-level signal during waveform output.

Output format	Open-drain output (with 5 V voltage output), low active
Output voltage levels	HIGH level: 4.0 V to 5.0 V LOW level: 0 V to 0.5 V
Maximum switching capacity	5 V DC to 30 V, 50 mA

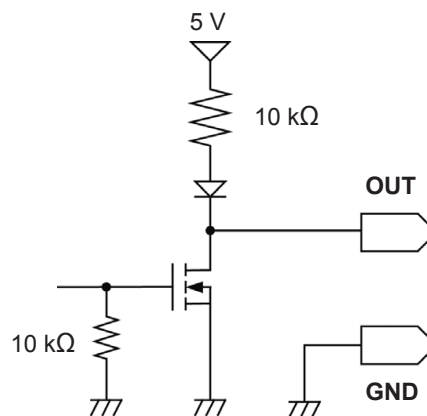

- When the output waveform is a program waveform (p.59), a LOW-level signal will be output from the OUT pin approximately 2.5 ms before the start of waveform output. When the output waveform is not a program waveform, a LOW-level signal will be output from the OUT pin approximately 0.6 ms before the start of waveform output.
- When the program function step is being held or when the control state is **[PAUSE]**, a HIGH-level signal will be output from the OUT pin.



# 13 Waveform Maker

## 13.1 Overview of the SF8000 Waveform Maker

### Operating environment

Operating system	Personal computer (PC) capable of running Windows 7 (32-bit/64-bit) or Windows 8.1 (32-bit, 64-bit) Windows 10 (32-bit, 64-bit) (with English and Japanese language support) (Microsoft .NET Framework Ver. 4 or later must be installed.)
CPU	Pentium (1 GHz) or better
RAM	2 GB or more
Monitor resolution	1024 × 768 or higher
Interfaces	Ethernet port (in order to send and receive created data)

### Functional specifications

Arbitrary waveforms	Waveform input	Support for waveform input, function input, step input, interpolation input
	Waveform input	Input from a file 8847, MR8847, MR8847A, MR8827, MR8740, MR8741 formats PW3198 format CSV format (format used by Memory HiCorders and this application)
		Input by specifying a basic waveform Sine wave, rectangular wave, triangular wave, ramp wave, SIN (x)/x wave, EXP wave, noise, DC (with variable duration, amplitude, offset, cycle count, and phase)
		Input using a drawing tool Free-form curve or straight line
	Function input	14 types of functions ABS (absolute value), SIN (sine), COS (cosine), DIFF (differential), INTG (integration), CINT (conversion to integer), EXP (exponent), LOG (natural logarithm), NRND (random number), SQUR (square root), RMPD (ramp-down), RAMPU (ramp-up), TRI (triangular wave), INV (inverse)
		7 control words AREA, END, FOR, NEXT, PERIOD, PI, STEP, T, TO, V
	Step input	Input by setting a waveform for each step (max. 100 steps)
		Selection of basic waveforms Sine wave, rectangular wave, triangular wave, ramp wave, SIN(x)/x wave, EXP wave, noise, DC
	Interpolation Input	Maximum number of dots that can be entered: 200
		Dot interpolation method Curve Straight
	Editing of inputted waveforms	Cut, copy, paste, and clear functions
	Calculations using inputted waveforms	Addition, subtraction, multiplication, normalization, size modification, absolute value, inversion, mirror
Modification of waveform display	Zoom in, zoom out, scroll, TIME/DIV display, V/DIV display, point display (time axis, voltage axis), percent display (voltage axis)	

	Modification of waveform display	Zoom in, zoom out, scroll, TIME/DIV display, V/DIV display, point display (time axis, voltage axis), percent display (voltage axis)
	Loadable file formats	SF8000 format (FGW) 7990, 7075 format (WFG) 8847, MR8847, MR8847A, MR8827, MR8740, MR8741 format (MEM,CSV) PW3198 format (EVT)
Arbitrary waveforms	Save file format	SF8000 format (FGW) 7990, 7075 format (WFG)
Pulse patterns	Input	Input using dedicated editor Select range, copy, paste, delete, and other editing functions are supported in the editor.
	Loadable file formats	SF8000 format (PLS) CSV format
	Save file format	SF8000 format (PLS)
Data transfer	Interface	LAN
	Arbitrary waveforms	Arbitrary waveform data can be transferred to the selected save block (numbered 1 through 8) in the recorder's memory.
	Pulse patterns	Data can be transferred to the selected pattern (numbered 1 through 16) in the recorder's memory.

## 13.2 Installing the SF8000 Application

This section describes how to install the SF8000 application. The following procedure uses a Windows 8.1 installation as an example but messages and steps may vary depending on the operating system and settings in use.

### IMPORTANT

Exit any anti-virus or similar software before installing the application. Anti-virus software may prevent the application from being properly installed.

- 1 Start up Windows®.**  
Exit any other software that is running.
- 2 Place the included CD-R disc in the CD-ROM drive.**  
Display the SF8000 software installation window and click the **[Install]** icon at the top right of the screen. Click the **[RUN]** button on the confirmation dialog box to launch the installer.
- 3 Click the **[Next>]** button.**

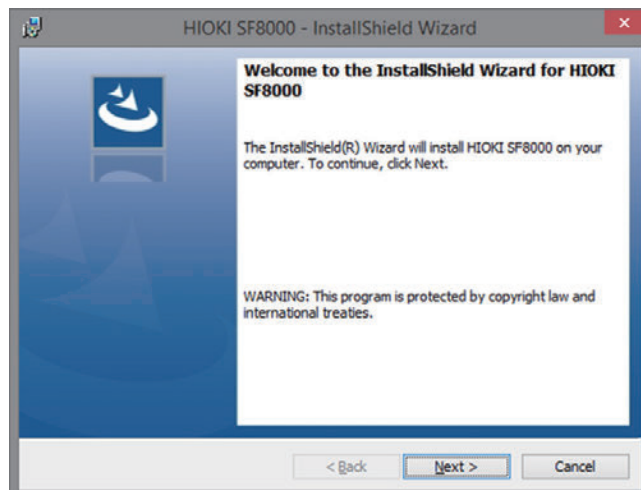

- 4 Click the **[Next>]** button once you have accepted the software license.**



- 5** To change the installation location, click **[Change]**.  
Click **[Next>]**.

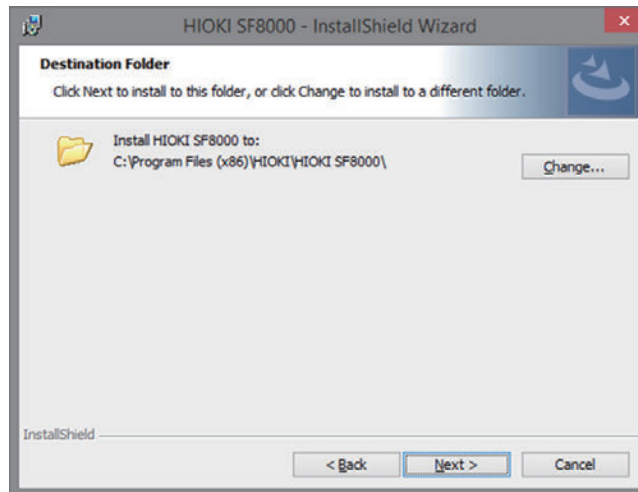

- 6** If the user account control is displayed, click **[Install]**.  
The installation will begin.

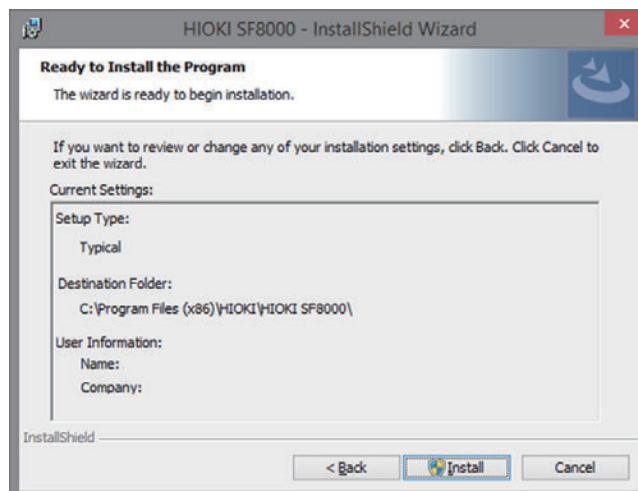

- 7** Click the **[Finish]** button.  
The installation is complete.

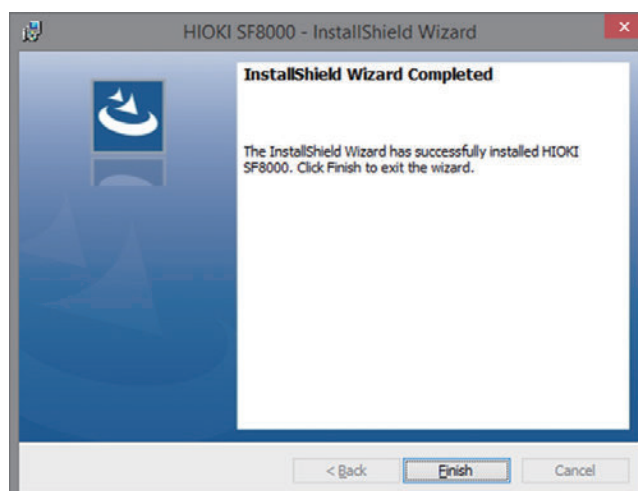

## 13.3 Launching and Exiting the SF8000 Application

### Launching the application

Example: Windows 8.1

- 1 Click **[Start]** on the charm bar.

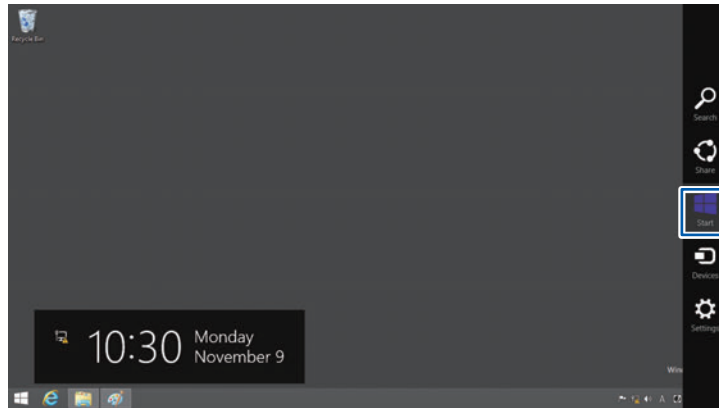

- 2 Click **[SF8000]** on the Start menu.

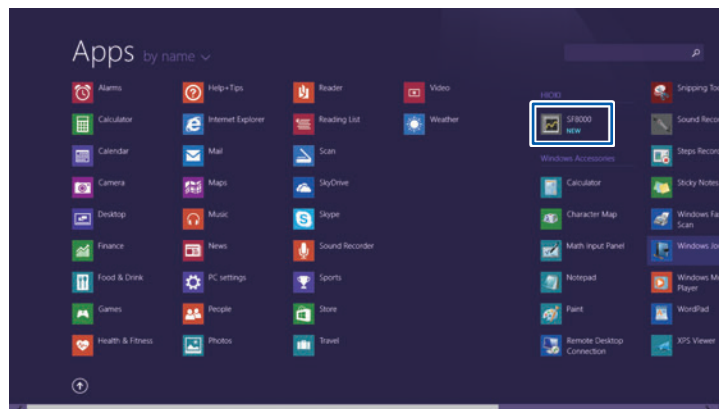

## Exiting the application

### Example: Windows 8.1

Click **[Exit]** on the “File” menu on the main window or click the close button **[×]** at the top right of the main window.

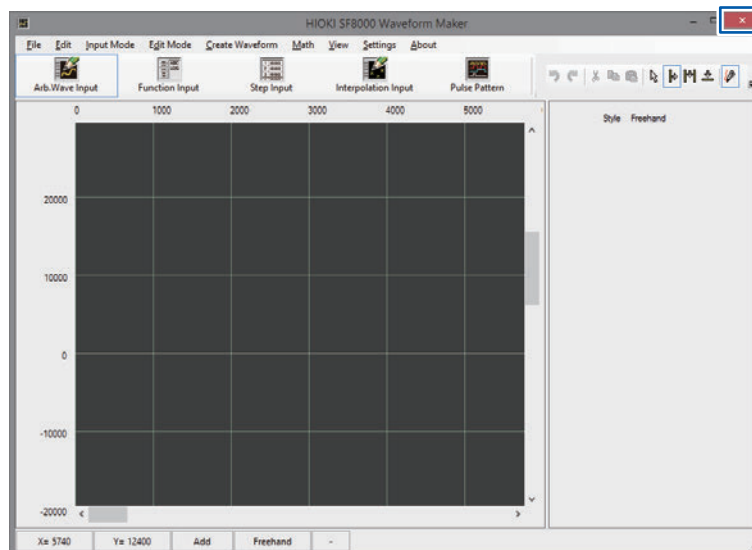
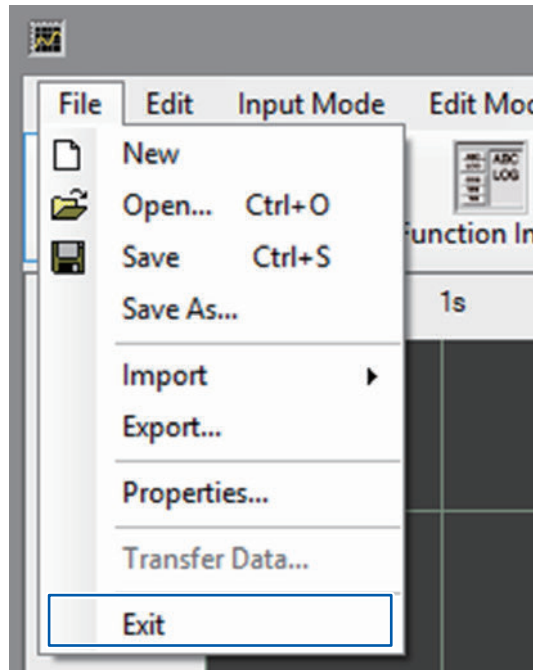

## 13.4 Uninstalling the SF8000 Application

- 1 Double-click on **[Uninstall a program]** on the Control Panel.

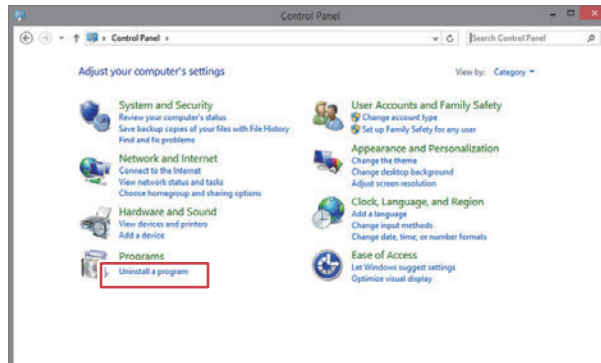

- 2 Select **[HIOKI SF8000]** from the list of currently installed programs and delete it.

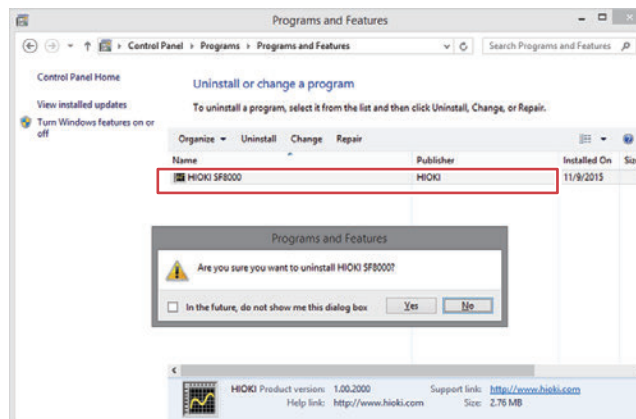

- 3 The installer will be launched automatically to uninstall the program.

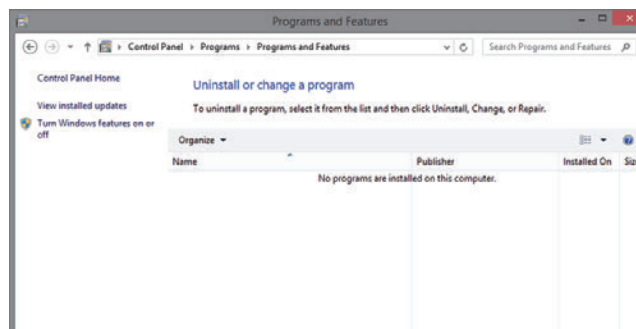

## 13.5 SF8000 Screen

The SF8000 provides a total of four modes, three for creating waveforms to be output from the U8793 (arbitrary waveform input mode, function input mode, and step input mode) and one for creating pulse patterns to be output from the MR8791. Each mode has its own screen. Each screen includes a waveform input mode selection button, menu bar, toolbar, and status bar, allowing the user to accomplish such tasks as selecting the application mode, creating waveforms, and saving and transferring data.

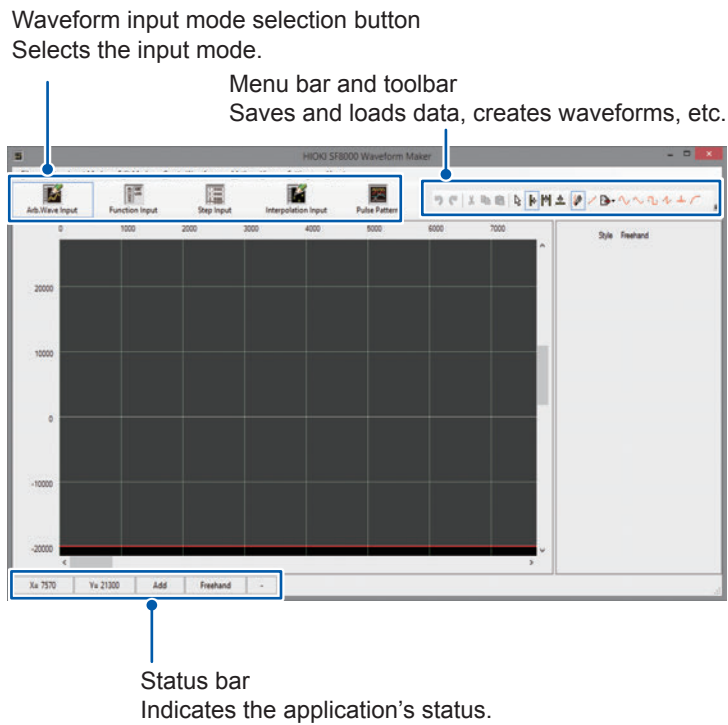

## Setting the display format

Set the format used in the waveform display area under **[View]** on the menu bar.

X-axis▶	–
Time/Div	Displays as the output time.
Point	Displays as the number of data points.
Y-axis▶	–
V/Div	Displays as the voltage axis.
Point	Displays as the number of data points.
%	Displays as a percentage of the maximum value.
Grid▶	–
ON	Displays grid lines.
OFF	Hides grid lines.
Expand X-axis	Enlarges the waveform's X-axis display.
Shrink X-axis	Shrinks the waveform's X-axis display.
Expand Y-axis	Enlarges the waveform's Y-axis display.
Shrink Y-axis	Shrinks the waveform's Y-axis display.
Properties▶	–
Show	Displays property information for the waveform being edited.
Hide	Hides property information for the waveform being edited.
	–

## Setting the time axis range

Select **[Settings - Range]** from the menu bar to change the time axis scale used in the waveform display area. The time axis range is determined by the combination of the value selected as the range and the units, with 1 div. equivalent to 100 points.

## Input mode screens

### Arbitrary waveform input mode

In this mode, arbitrary waveforms are created using drawing tools.

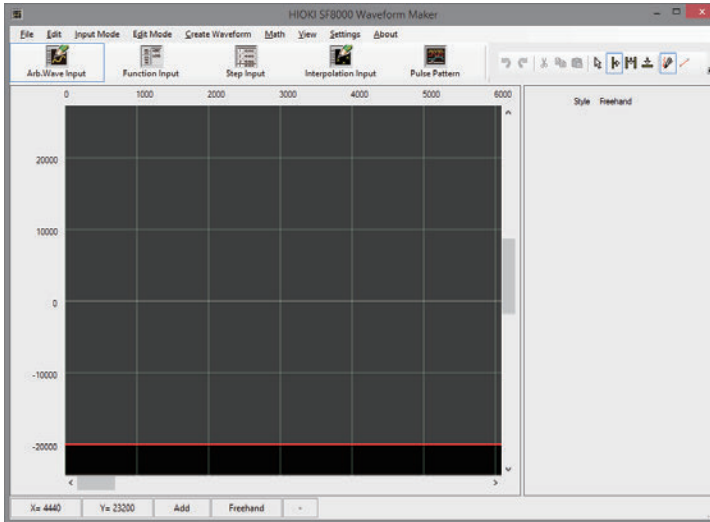

### Function input mode

In this mode, arbitrary waveforms are created by entering functions.

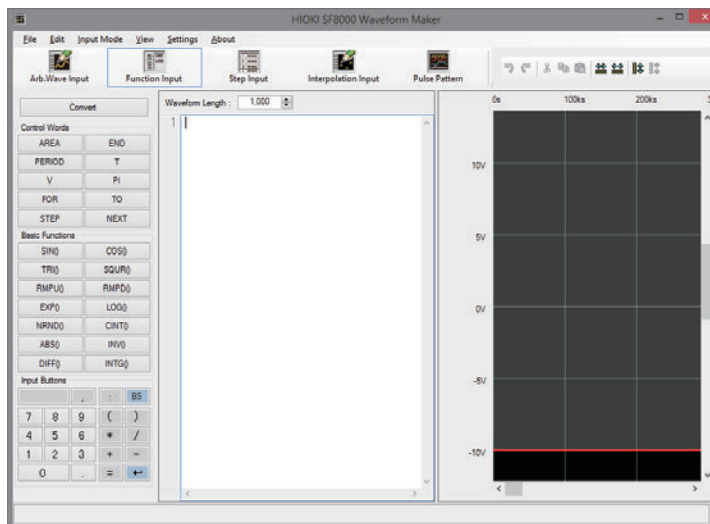

**Step input mode**

In this mode, arbitrary waveforms are created by entering waveform settings for each step (on one line at a time).

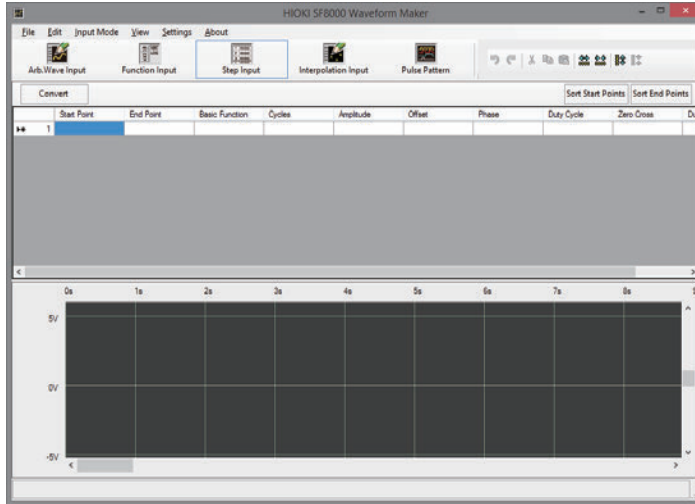

**Interpolation Inputmode**

This mode is used to create a user-defined waveform by interpolating between entered dots.

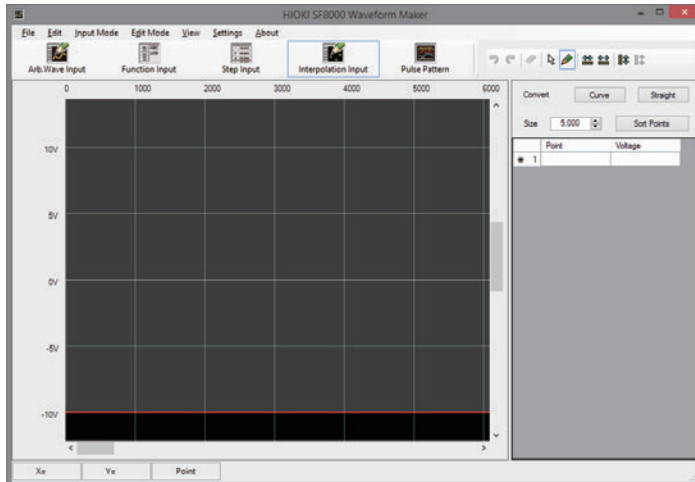

**Pulse pattern mode**

In this mode, pulse patterns that are output from the MR8791 are created.

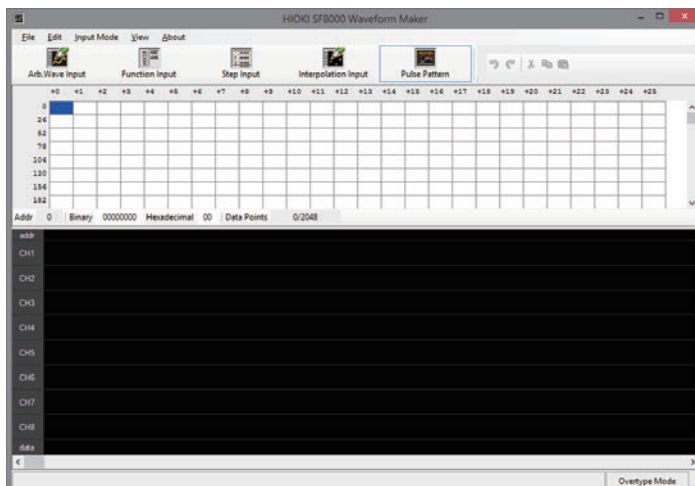

## 13.6 Arbitrary Waveform Input Mode

Click the **Waveform Input** button or select **[Waveform Input Mode - Arb. Wave Input]** from the menu bar to enable arbitrary waveform input mode.

### Basic instructions

#### Entering waveforms with the mouse

In general, waveforms are created by dragging with the mouse. The position at which the left mouse button is pressed becomes the start point, and the position at which the button is released becomes the end point. The waveform's phase can be reversed by changing the direction in which the mouse is dragged.

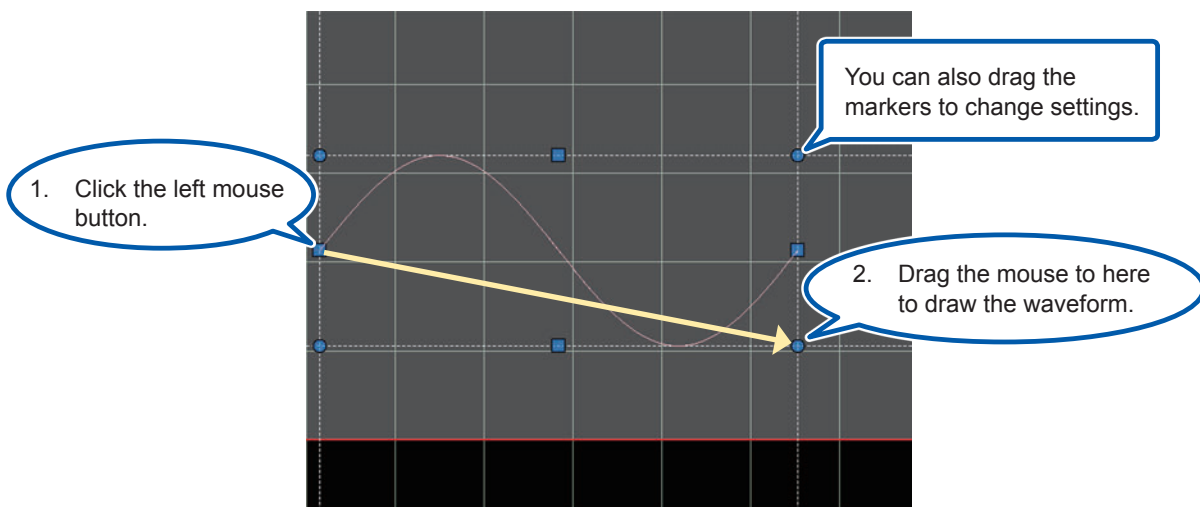

Even after you release the mouse button, you can change settings such as the points and scale by dragging the ● and ■ markers. At this time, clicking an area other than the markers will cause the markers to disappear, finalizing waveform input. Clicking the left mouse button once while the markers are displayed will cause the input to be finalized, and the markers will disappear.

#### Changing settings by entering properties

Settings also can be changed after waveform input has been finalized in the property entry area on the right side of the screen.

#### Waveform input range

The horizontal red lines at the top of the screen indicate the upper and lower limits of the range within which waveforms can be input. Data that exceeds this range will be clipped at the upper and lower limits.

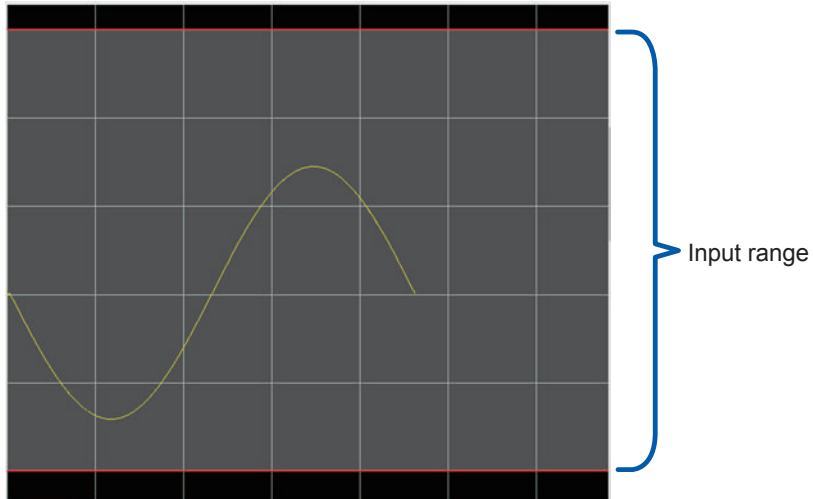

## Editing mode

Select the waveform input method.

### Select

Selects the position or range of the input waveform. The selection range varies with mouse operation.

- Left single click: Selects the position.
- Drag using left button: Selects a range.
- Left double click: Selects one waveform period.

### Add

Adds the waveform to the end of the input waveform. If space is left between the end position of the already created waveform, the software will interpolate with a straight line.



### Insert

Inserts a waveform between two segments of the previously input waveform.



### Overwrite

Overwrites a previously input waveform with a new waveform.









## Waveform creation

Select the type of waveform to input. If the waveform is stored in a file, load one of the waveform data file types listed below.

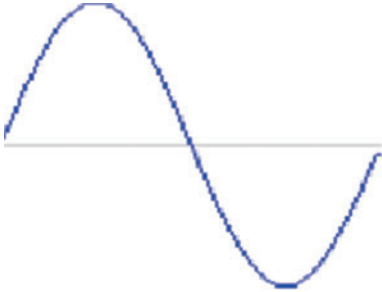
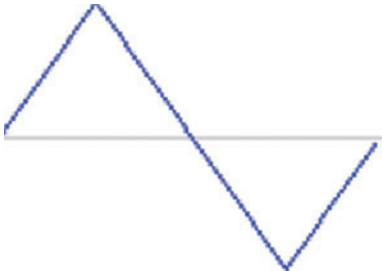
File...	
Power Meter Data...	PW3198 format
Memory HiCorder Data...	MR8740/MR8741/MR8827/MR8847 format
SF8000 Data...	7990/7075 format

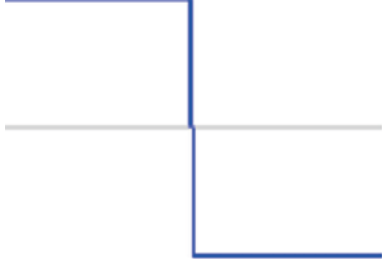
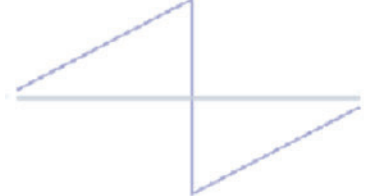
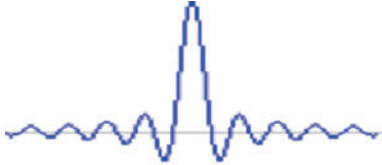

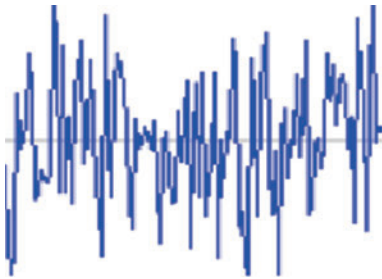
The following waveform types are available. Property values should be set based on the type of waveform selected.

Waveform type	Example of drawn waveform	Properties to set
Freehand		None (Curve is drawn based on mouse movements.)
Straight Line		Start point, number of points
Sine Wave		Start point, number of points, amplitude, offset, period, phase
Triangle Wave		Start point, number of points, amplitude, offset, period, phase

Waveform type	Example of drawn waveform	Properties to set
Pulse Wave		Start point, number of points, amplitude, offset, period, phase, duty ratio
Ramp Wave		Start point, number of points, amplitude, offset, period, phase
Sin (X)/X		Start point, number of points, amplitude, offset, period, phase, zero-cross
Exp		Start point, number of points, amplitude, offset, period, phase, attenuation rate
Noise		Start point, number of points, amplitude, offset
DC		Start point, number of points, offset

## Properties

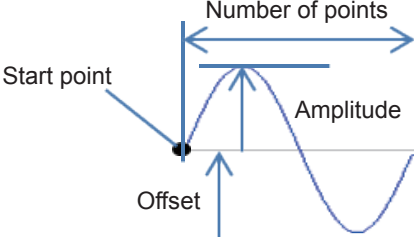
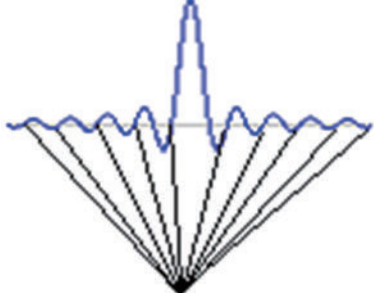
Set the properties described below according to the type of waveform you selected.

Property	Description
Start Point Number of Points Amplitude Offset Period	 <p>The diagram shows a sine wave starting from a point labeled 'Start point'. A vertical arrow labeled 'Offset' indicates the distance from the start point to the horizontal center line. A vertical arrow labeled 'Amplitude' indicates the height from the center line to the peak. A horizontal double-headed arrow labeled 'Number of points' spans the width of the wave.</p>
Phase	Number of waveforms
Zero-cross	 <p>The diagram shows a series of waveforms of varying amplitudes and phases, all originating from a single point at the bottom. A horizontal line represents the zero-crossing point. The text below the diagram reads 'Number of intersections with Y = 0 line'.</p>
Attenuation rate	 <p>The diagram shows two curves on a coordinate system. The left curve is a downward-opening parabola, labeled 'When value &lt; 0'. The right curve is an upward-opening parabola, labeled 'When 0 &lt; value'.</p>

## Calculations using previously input waveforms

Calculations can be performed using previously input waveforms. First, set the editing mode to “Select” and then select the calculation range.

Add	Adds a basic waveform or constant to a previously input waveform. The basic waveform or constant can be set in the properties area.
Subtract	Subtracts a basic waveform or constant from a previously input waveform. The basic waveform or constant can be set in the properties area.
Multiply	Multiplies a previously input waveform by a basic waveform or constant. The basic waveform or constant can be set in the properties area.
Normalize	Adjusts a waveform's peak value to the range's maximum value.
Resize	Changes a waveform's size.
Absolute Value	Calculates a waveform's absolute value.
Invert	Inverts a waveform's polarity.
Mirror	Flips data around the time axis.

## 13.7 Function Input Mode

This section describes how to generate waveform data by creating a function formula and then performing waveform conversion. Click the **Function Input** button or select **[Waveform Input Mode - Function Input]** from the menu bar.

### Basic instructions

After first setting the waveform size, create a function expression by combining control words and basic functions. Pressing the **Convert** button will display the waveform on the Waveform Display Preview screen.

### Example of program creation

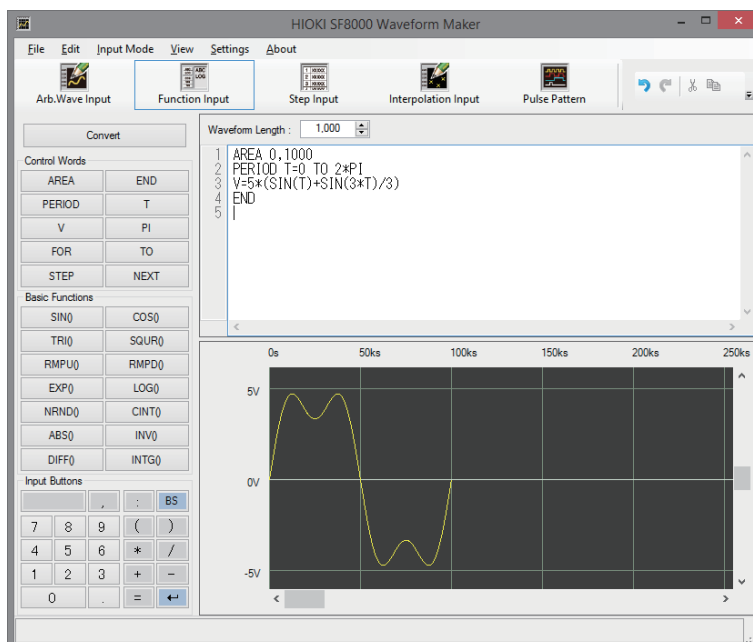

Line	Program code	Meaning
1	AREA 0,1000	Sets the editing range to a value that is less than or equal to the waveform size. Since the waveform size is 1000, this line declares the editing range to be from 0 to 1000.
2	PERIOD T=0 TO 2*PI	Sets the time constant T for a function with a time variable. Without this line, the range of T would be 0 to 2PI.
3	V=5*(SIN(T)+SIN(3*T))/3	Stores the data obtained from the formula on the right side of the equation in V.
4	END	Declares the end of the program. Once this command appears, subsequent commands will not be used in waveform conversion.

## Expressions and operations

“Expression” is a general term for standard formulas that join constants and variables with operators (special symbols used in calculations) or simply indicate a value, variable, or function. “Operation” refers to the execution of the operations included in an expression that consists of operators or functions. Calculations include arithmetic operations and functions. Arithmetic operations consist of the following operators and are performed in a predefined order:

Arithmetic operator	Description of calculation performed	Example
$\wedge$	Exponent (power)	$X^Y$
$-$	Sign	$-X$
$*$ , $/$	Multiplication, division	$X*Y$ , $X/Y$
$+$ , $-$	Addition, subtraction	$X+Y$ , $X-Y$

“Function” refers to an operation performed on a specified value (function argument) to obtain a result. (Not all functions require an argument.) Functions are expressed by words that are determined by the specific function performed, much like normal instructions (AREA, PERIOD, etc.). The words used to denote instructions are known as control words and are treated, along with functions, as special words.

Operations are subject to precedence. Operations are performed in the following order of precedence:

1. Expressions enclosed in parentheses
2. Functions
3.  $\wedge$  (exponents)
4.  $+$ ,  $-$  (sign)
5.  $*$ ,  $/$  (multiplication, division)
6.  $+$ ,  $-$  (addition, subtraction)

Parentheses are used to change the order of operation precedence. Operators enclosed in parentheses are executed before other operations. Expressions enclosed in parentheses are evaluated in accordance with the order of precedence.

## Control words

The following words are used to denote instructions.

AREA	
Function	Specifies the editing range.
Format	AREA <start point>, <end point>
Example	AREA 0,500
Explanation	This control word specifies the editing range for the instruction that follows it. The <start point> must be greater than or equal to 0 and less than the <end point>. The <end point> must be greater than the <start point> and less than or equal to the waveform size. If this instruction is omitted, a <start point> of 0 and an <end point> equal to the waveform size will be used. Instructions occurring between the AREA instruction and the next AREA instruction or END instruction will be valid from the <start point> to (<end point> - 1). However, the presence of a PERIOD instruction in that interval will cause data to be repeatedly generated in the specified variation domain. In this case, waveform data will be generated from the <start point> to (<end point> - 1) by the V instruction.

END	
Function	Declares the end of the program.
Format	END
Example	END
Explanation	This control word signals the end of program operations. Any instructions following this instruction will be ignored. The final END instruction in the program may be omitted.

FOR... TO... STEP to NEXT	
Function	Repeatedly executes the series of instructions included between "FOR" and "NEXT."
Format	FOR <variable name> = <Initial value> TO <end value> [STEP <increment>] ~ NEXT
Example	FOR J=0 TO 100 STEP 2 ↓ ~ NEXT
Explanation	<p>The instructions contained inside the FOR... NEXT loop will be repeatedly executed according to the conditions specified in the FOR instruction. Set the &lt;initial value&gt; to the variable's initial value. Set the &lt;end value&gt; to the variable's final value. Set the &lt;increment&gt; to the increment you wish to use between the start value and end value.</p> <p>The example above sets J to 0 before executing the instructions following the FOR instruction. When program execution reaches the NEXT instruction, the J value is increased by the increment of 2 so that it then equals 2, and the instructions following the FOR instruction are again executed. This process is repeated until J equals 100. If [STEP &lt;increment&gt;] were omitted, an &lt;increment&gt; of 1 would be used.</p> <p>If the &lt;start value&gt; or &lt;increment&gt; is greater than the &lt;end value&gt;, the instructions following the FOR instruction will only be executed with the &lt;start value&gt;.</p> <p>Caution FOR... NEXT loops cannot include AREA instructions, PERIOD instructions, other FOR... NEXT loops, or V instructions containing DIFF or INTG instructions.</p>

PERIOD	
Function	Specifies the variation domain of the period variable T.
Format	PERIOD T=<default value> TO <end value>
Example	PERIOD T=0 TO PI
Explanation	This instruction is used to specify the variation domain of the variable T, which is a reserved word. The variable T varies from the <default value> to the <end value> within the area specified with the AREA instruction. In the absence of a PERIOD instruction, or immediately after an AREA instruction, the <default value> is 0, and the <end value> is $2\pi$ . When there is a PERIOD instruction, the instructions included before the next AREA instruction, END instruction, or the last line of the program are repeated based on the AREA instruction that is valid at that time.

PI	
Function	Serves as a constant that expresses the ratio of the circumference of a circle to its diameter ( $\pi$ ).
Format	PI
Example	A=2*PI
Explanation	This instruction is used to denote the ratio of the circumference of a circle to its diameter. Its value is approximately 3.141593.

T	
Function	Used as the period variable.
Format	T
Example	AREA0,10 PERIODT=0 to 2*PI V=10*SIN(T)
Explanation	T is a variable. A PERIOD instruction must be used to change the value of T. In the above example, the SIN (sine) is calculated with $T = 0$ when the area is 0 to generate waveform data. Next, a series of substitutions are performed until the data has been generated, setting the value of T to $\pi/5$ when the area is 1, to $2\pi/5$ when the area is 2, and to $9\pi/5$ when the area is 9.

V	
Function	Serves as a variable for storing actual data.
Format	V
Example	V=10
Explanation	Although V is a variable, it differs from other variables in that it consists of an array containing the same number of elements as the length of the set waveform size, with each element in the array storing the actual waveform data. Each element in the array is set to 0 by default and stores a value as an expression. When the stored data is retrieved, it is necessary to perform calculations to evaluate the expression.

## Functions

Functions perform a predetermined calculation on a specified value (the function argument).

ABS	
Function	Calculates the absolute value.
Format	ABS (<expression>)
Example	B=ABS(-2)
Explanation	The function calculates the absolute value of the <expression>.

CINT	
Function	Converts a decimal to an integer.
Format	CINT (<expression>)
Example	A=CINT(2.5)
Explanation	The function converts <expression> to an integer by rounding off the decimal portion.

COS	
Function	Calculates the cosine.
Format	COS (<expression>)
Example	X=COS(PI/4)
Explanation	This function calculates the cosine of <expression>, which is specified in radians as a value from -2,147,483,648 to 2,147,483,647.

DIFF	
Function	Calculates the differential.
Format	DIFF (V)
Example	V=10*DIFF(V)
Explanation	This function differentiates all data in the area containing the instruction and stores the result as new data. It can only be in a V instruction (instruction starting with "V=") outside a FOR loop, and only the four basic arithmetic functions can be performed simultaneously. In addition, PERIOD instructions, FOR... NEXT instructions, and V instructions other than differentials and integrals cannot be performed from the line containing this instruction to the next AREA instruction or END instruction. A 5-degree Lagrange interpolation formula is used to calculate differentials. Data values greater than 10 V generated with this function are converted to 10 V, while data values less than -10 V generated with this function are converted to -10 V.

EXP	
Function	Calculates the value of the exponent function with e (natural logarithm base).
Format	EXP (<expression>)
Example	E=EXP(1)
Explanation	This function obtains the result of raising <expression> to the eth power, where <expression> is specified as a value from -708 to 709.

INTG	
Function	Calculates the integral.
Format	INTG (V)
Example	V=INTG(V)/2
Explanation	This function integrates all data in the area containing the instruction and stores the result as new data. It can only be used in a V instruction (i.e., an instruction starting with "V=") outside a FOR loop, and only the four basic arithmetic functions can be performed simultaneously. In addition, PERIOD instructions, FOR instructions, NEXT instructions, and V instructions other than differentials and integrals cannot be performed from the line containing this instruction to the next AREA instruction or END instruction. A trapezoidal formula is used to calculate integrals. Data values greater than 10 V generated with this function are converted to 10 V, while data values less than -10 V generated with this function are converted to -10 V.

INV	
Function	Calculates the result of reversing the sign.
Format	INV (<expression>)
Example	A=INV(B)
Explanation	This function calculates the result of reversing the sign of <expression>.

LOG	
Function	Calculates the natural logarithm value.
Format	LOG (<expression>)
Example	L=LOG(35/9)
Explanation	This function calculates the natural logarithm (logarithm with a base of e) of <expression>, which must be specified as a positive value.

NRND	
Functions	Calculates a random number.
Format	NRND (<expression>)
Example	R=RND(2)
Explanation	This function calculates a pseudo-random number that indicates a standard normal distribution (with an average of 0 and a variance of 1) that is greater than or equal to -1 and less than +1. The <expression> can be specified as an integer that is greater than or equal to 0 and less than or equal to 32767. This value can be used to change sequence of the random numbers obtained from the function.

RMPD	
Function	Calculates the value of a ramp-down wave (saw-tooth wave).
Format	RMPD (<expression>)
Example	X=RMPD(PI/8)
Explanation	This function calculates the value of a ramp-down wave (saw-tooth wave) for <expression>, which is specified in radians as a value from -214,748 to -214,747.

RMPU	
Function	Calculates the value of a ramp-up wave (saw-tooth wave).
Format	RMPU (<expression>)
Example	X=RMPU(PI/4)
Explanation	This function calculates the value of a ramp-up wave (saw-tooth wave) for <expression>, which is specified in radians as a value from -214,748 to 214,747.

SIN	
Function	Calculates the sine value.
Format	SIN (<expression>)
Example	X=SIN(PI/8)
Explanation	This function calculates the sine of <expression>, which is specified in radians as a value from -2,147,483,648 to 2,147,483,647.

SQUR	
Function	Calculates the value of a rectangular wave (square wave).
Format	SQUR (<expression>)
Example	X=SQUR(PI/8)
Explanation	This function calculates the value of a rectangular wave (square wave) function for <expression>, which is specified in radians as a value from -214,748 to 214,747.

TRI	
Function	Calculates the value of a triangular wave.
Format	TRI (<expression>)
Example	X=TRI(PI/8)
Explanation	This function calculates the value of a triangular wave function for <expression>, which is specified in radians as a value from -214,748 to 214,747.

## Usable characters

The following characters can be used:

Uppercase and lowercase alphabetical characters	A through Z and a through z	Uppercase and lowercase alphabetical letters are treated as being identical.
Numerals	0 through 9	Numerals are used to indicate a single value or character.
Period	.	The period is used as a single numeric character to indicate the decimal point.
Comma	,	The comma is used as a delimiter for AREA instruction parameters. [Example] AREA200,350↓
Arithmetic operators	*, /, +, -	Arithmetic operators are used as normal operations or to indicate the sign of a value.
Caret	^	The caret is used when raising a value to a power.
Colon	:	The colon is used as a delimiter in multiple statements (when including multiple instructions on a single line). [Example] AREA 100,200:PERIODT=0 TO 2*PI↓
Apostrophe	'	The apostrophe is used to mark the start of a comment in a program. Text from this symbol to the next return (↓) character is not recognized as program instructions. In other words, comments have no effect on the function program.
Underscore	_	The underscore is used as an alphabetical character. It can also be used as the start of an alphabetical word.
Equal sign	=	The equal sign is used as the assignment operator for V instructions and variable instructions.
Return	↓	The return character is used to indicate a line feed in the program.
Space		The space is used as a delimiter between words. It can also be used in expressions.

### Constants

Constants have fixed values and can be included directly in programs. They consist of numerals (0 through 9) and a decimal point (.). They are expressed as real, decimal numbers and must be no more than 12 numerals in length. (Neither hexadecimal nor exponential notation may be used.)

### Variables

Variables serve as containers for storing data (values and constants) in programs. A total of 128 can be used. Variables are given an alphabetical name and have the value 0 until they are used to store a value. Variable names consist of eight or fewer characters and may include alphanumerical characters (A through Z, a through z, and 0 through 9) as well as the underscore (\_) and period (.) characters. However, they must begin with a letter or underscore character. Although reserved words may not be used as variable names, variable names may contain such words. No distinction is made between uppercase and lowercase letters.

# 13.8 Step Input Mode

In step input mode, waveform data is created by setting and combining step waveforms. Click the step input button or select **[Waveform Input Mode - Step Input]** from the menu bar.

## Basic instructions

Enter the start and end point for each step as well as the waveform type and settings. Once you have entered one step, the waveform will be drawn in the waveform preview area of the screen. Up to 100 steps can be entered.

## Example of waveform creation

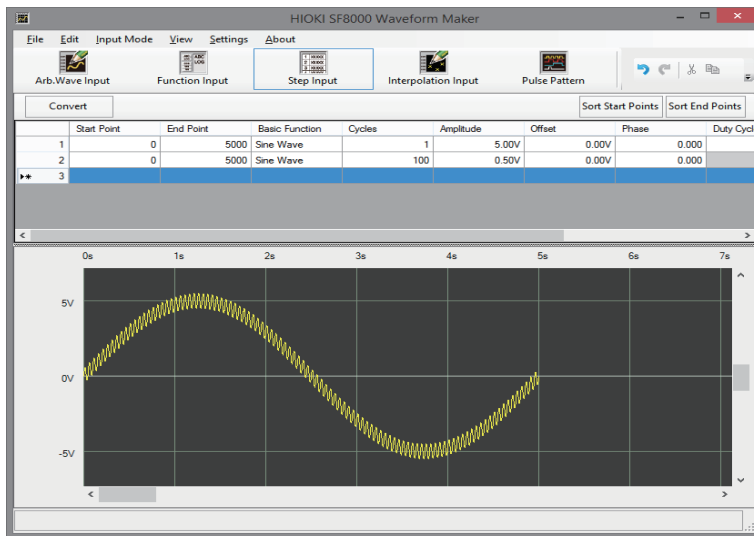

Start point	End point	Basic function	Period	Amplitude	Offset	Phase
0	5000	Sine wave	1	5 V	0 V	0
0	5000	Sine wave	100	0.5 V	0 V	0

## Start and end point settings

Specify the waveform's start point and end point as a number of points. The data will include position data for the start point and end point. The valid input range is 0 to 249999.

## Waveform type and settings

The table below lists the settings associated with each waveform type. The waveform types and properties are the same as for arbitrary waveform creation mode.

	Sine wave	Pulse wave	Triangle wave	Ramp wave	SIN (X)/X wave	EXP wave	Noise	DC
Cycles	✓	✓	✓	✓	✓	✓	–	–
Coefficient	✓	✓	✓	✓	✓	✓	✓	–
Offset	✓	✓	✓	✓	✓	✓	✓	✓
Phase	✓	✓	✓	✓	✓	✓	–	–
Duty Cycle	–	✓	–	–	–	–	–	–
Zero-cross	–	–	–	–	✓	–	–	–
Attenuation ratio	–	–	–	–	–	✓	–	–

## Editing steps

You can select steps as desired and delete, copy, and paste them. Steps are selected by clicking on the numeral shown to the left of each step. These operations are accessible from **[File - Edit]** on the toolbar.

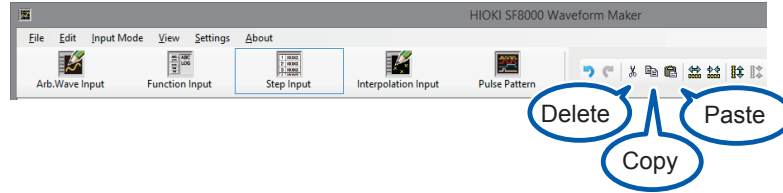

## Reordering the display

Pressing the Sort Start Points button reorders the list of steps in ascending order by start point value. Pressing the button again toggles between ascending and descending order.

Pressing the Sort End Points button reorders the list of steps in ascending order by end point value. Pressing the button again toggles between ascending and descending order.

	Sort Start Points	Sort End Points
Duty Cycle	Zero Cross	Dump Fact
50.000	10	-5.000
50.000	10	-5.000

# 13.9 Interpolation Input Mode

Waveform data is created by interpolating between multiple entered dots. Click the [Interpolation Input] button or select [Input Mode] – [Interpolation Input] from the menu bar.

## Basic instructions

### Setting the waveform size

Set the waveform size.(100 to 250,000)

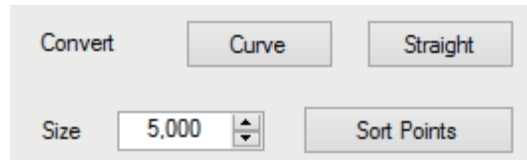

### Dot input with the mouse

Clicking the waveform creation area with the left mouse button causes a dot to be entered at that point. Enter only the necessary number of dots.

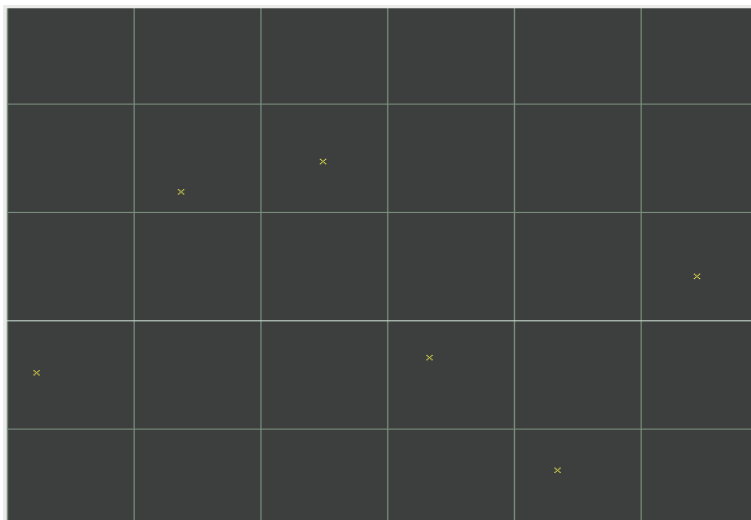

### Selecting the conversion method

Click the [Convert] button on the screen to select whether to use curves or straight lines to interpolate between dots.

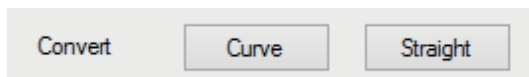

**Performing interpolation**

Interpolation will be performed using the selected method.

Interpolation with curves

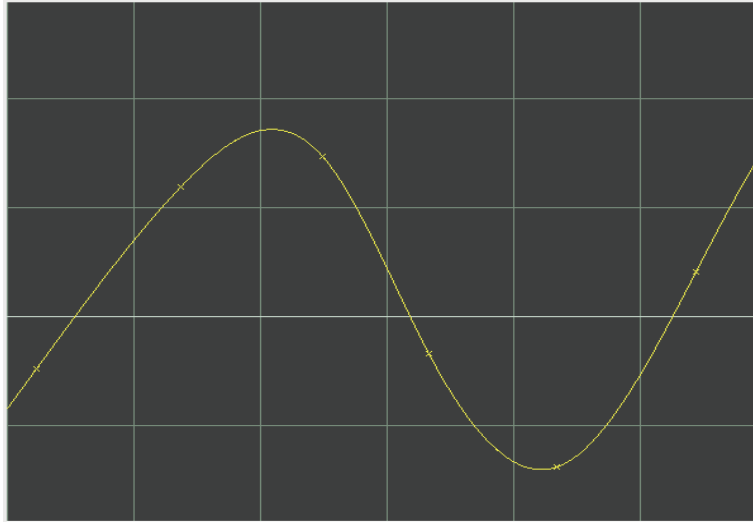

Interpolation with straight lines

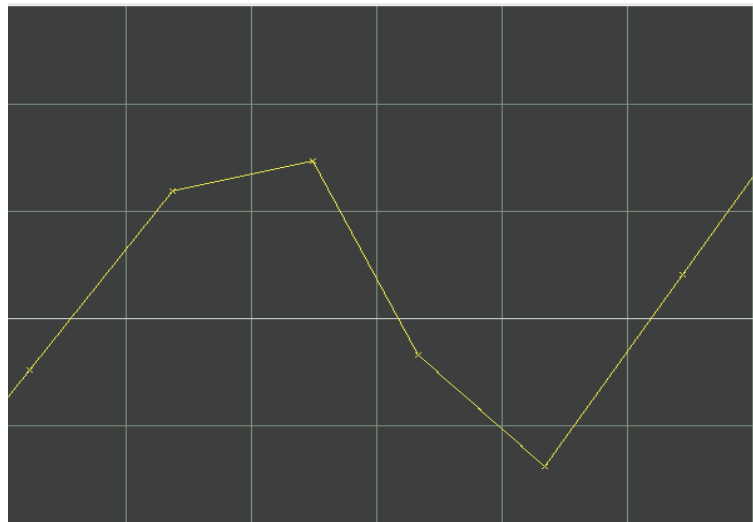

## Editing mode

Select the operation to perform when the mouse button is clicked.  
 Select **[Edit Mode]** on the menu bar or select the operation on the toolbar.

### Select

Select the range over which to interpolate between dots.



Left button click: Selects the start position. A vertical broken line will be displayed at the clicked position.  
 Right button click: Selects the range. A vertical broken line will be displayed at the clicked position, which will serve as the endpoint of the range.

The dots enclosed within the range defined by the two vertical broken lines will be interpolated.  
 (Dots in excess of the waveform size will be treated as outside the scope of interpolation.)

Clicking the left button while the two vertical broken lines are displayed will cancel the selected range.

### Dot input (default)



A dot will be entered at the position at which you click the left button. Up to 200 dots can be entered. In dot input mode, the selected range will be canceled, and dots within the waveform size will be subject to interpolation.

## Dot data list

Data for the entered dots will be shown in the dot data list on the right side of the screen. The time-axis position (number of points) and voltage value for each dot will be shown in the list.

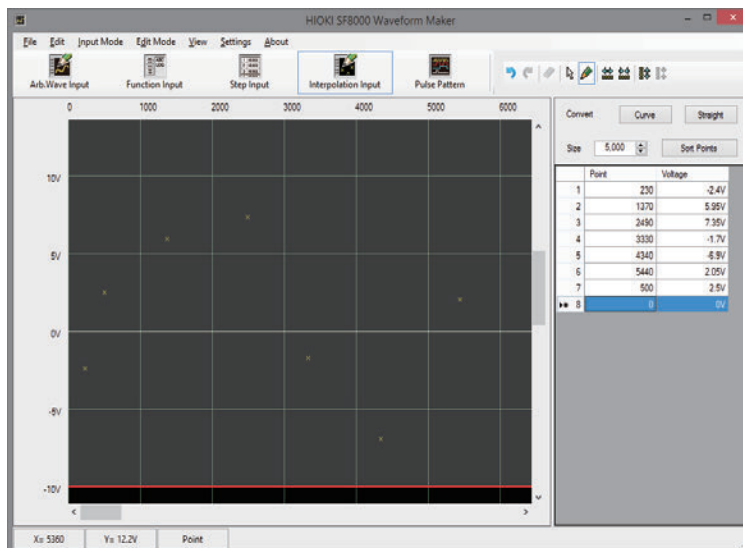

You can change dot data values and add and delete dots in the list.

### Changing the list

Click the value you wish to change with the mouse and enter the desired value using the keyboard. Finally, press the RETURN key to change the value.

### Adding the list

Enter a value on the bottommost row in the list to add it as a data for a new dot.

### Deleting the list

Click the row you wish to delete with the mouse and either select **[Edit] – [Clear]** on the menu bar or click the “Clear” button on the toolbar.

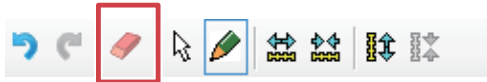

### Sorting the list

Click the **[Sort Points]** button above and to the right of the list to sort the dot data into ascending order based on point value.

## Interpolation method

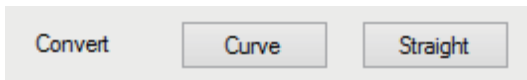

Click the **[Curve]** or **[Straight]** conversion button at the top of the screen to interpolate between the dots. Interpolation is performed as follows according to the type of interpolation and the number of target dots.

the type of interpolation	the number of target dots			
	0	1	2	3 or more
curves	None	DC (DC waveform at the dot position)	straight lines	Tertiary spline interpolation
straight lines	None	DC (DC waveform at the dot position)	straight lines	straight lines

When an interpolation range has been selected, only the dots within that range are subject to interpolation. However, if the start of the selected range does not intersect the line, straight-line interpolation will be performed with the endpoint of the line lying before the start position.

In addition, if there is no line data at the start position of the selected range, straight-line interpolation is performed with the coordinate (0,0).

Example: If there is no line data before the selected range

Before execution

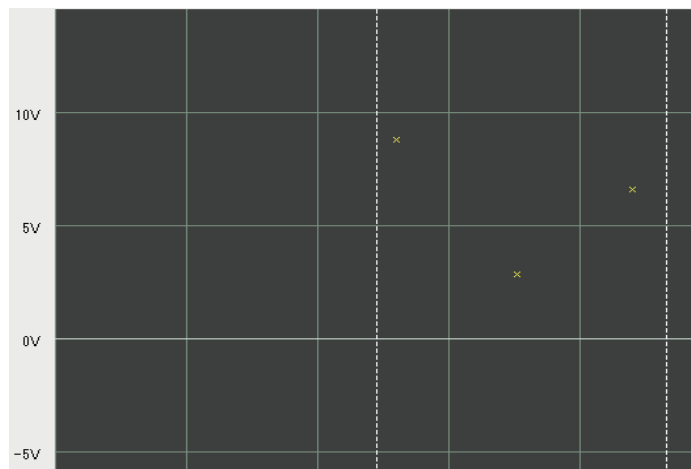

After execution

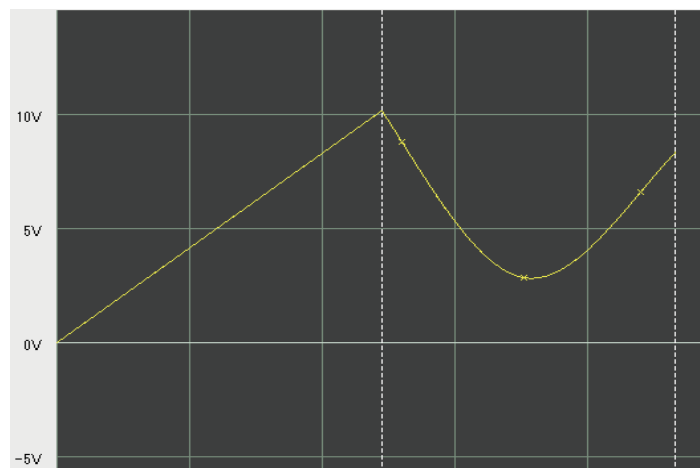

## 13.10 Pulse Pattern Mode

Pulse pattern mode is used to create pulse patterns for use with the MR8791. Pulse pattern data consists of 8 bits, each of which is allocated to one MR8791 channel (the device has a total of eight channels). (The LSB corresponds to Ch. 1, while the MSB corresponds to Ch. 8.)

The value 0 indicates the OFF state, while the value 1 indicates the ON state.

### Basic instructions

Up to 2048 data points can be configured. The top left corner of the data input area corresponds to the first data position and with the cell to its right to the second position, with the position increasing as you move to the right. Once the right side of the grid is reached, the data continues from the left side of the next line.

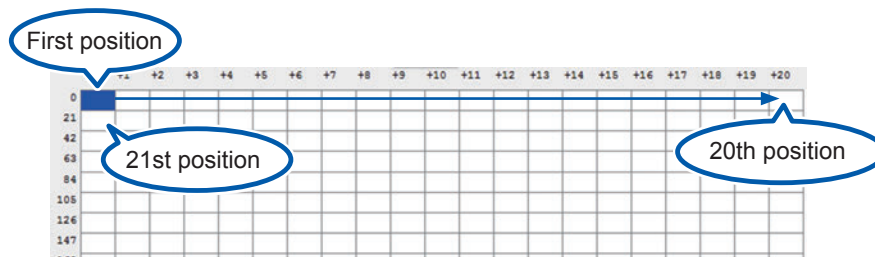

When you select the position at which you wish to enter data, the cell's background color will turn blue. Enter a hexadecimal value with the keyboard and press the return key to accept the entered value and display the waveform.

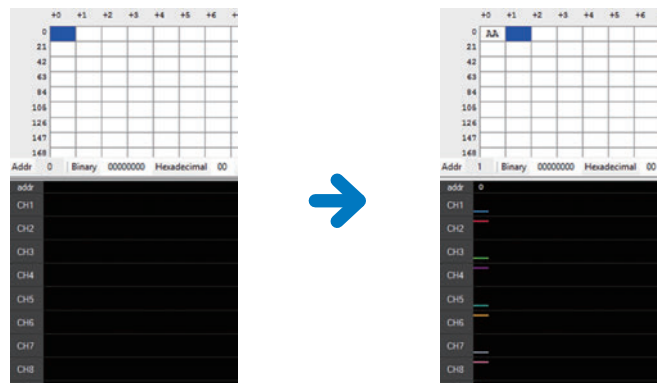

In addition to entering values directly at the desired positions, you may also enter values into the input text box underneath the grid, in which case you can also enter binary values.

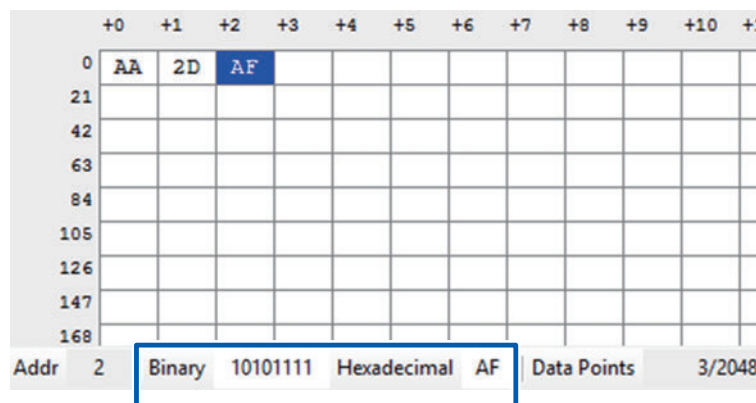

You can also select a range of data to copy and paste into other cells.

Drag the mouse to select the desired range and click the copy button.

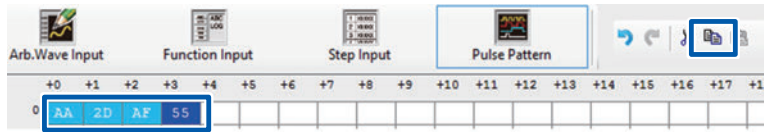

Select the position at which you wish to paste the data and click the paste button.



The copied data will be pasted.

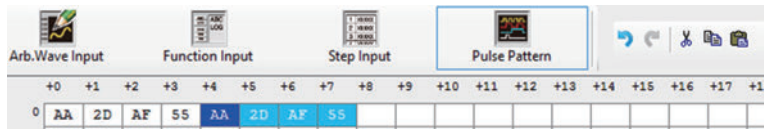

## Example of waveform creation

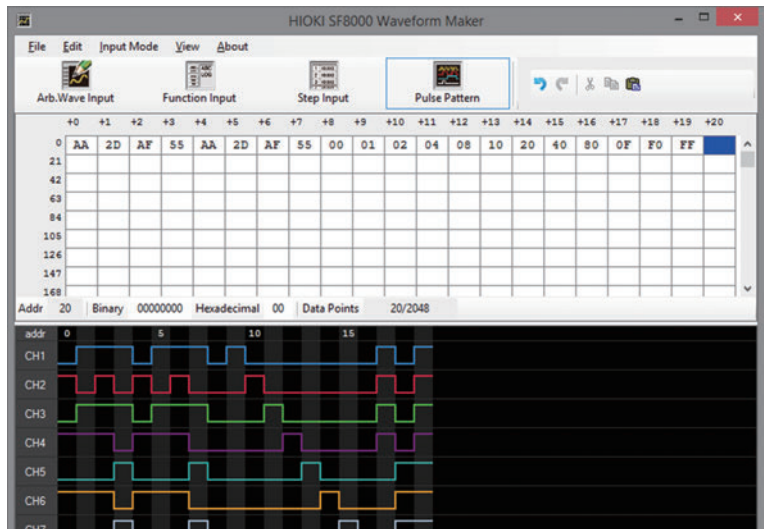

## 13.11 Transferring Data

This section describes how to transfer data to a LAN-connected Memory HiCorder.

- 1 Click “File - Export” from the Main screen’s menu bar.

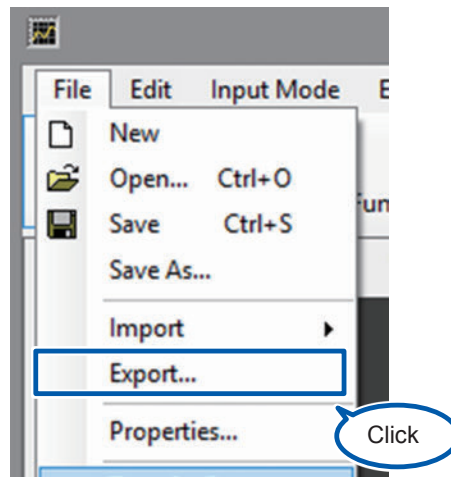

- 2 Enter the destination Memory HiCorder’s IP address and LAN port number.

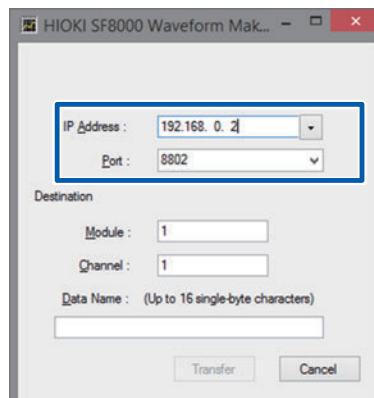

- 3 The destination instrument settings depend on the input mode. Arb. Wave Input, Function Input, or Step Input mode: Enter the unit number (Module), channel number (Channel), and data name and click the transfer button.

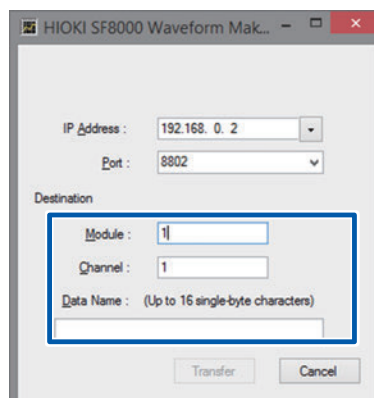

- 4** **Pulse pattern input mode:**  
Select the unit number (**Module**) and pattern number (**Pattern**) and click the transfer button.

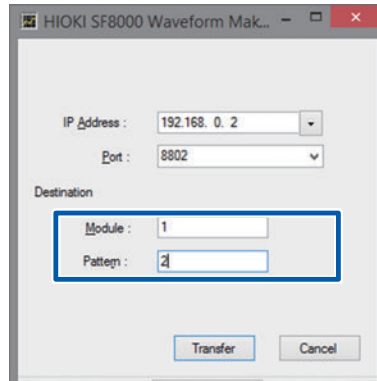

## 13.12 Saving and Loading Data

This section describes how to save created data and settings as files and how to load data and settings from files. You can save data and settings for all input modes together, or you can save waveform data alone for an individual input mode.

### Saving and loading all data

Click “File-Save As...” from the main screen’s menu bar. When the Save File dialog box is displayed, specify the destination and filename and save the data.

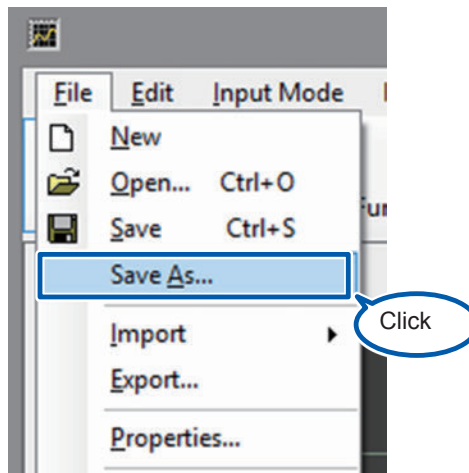

The saved file, which will have the extension “.fgw,” can only be loaded by the SF8000 application. To load a file, select the “File-Open” command.

To load created data into a recorder, use the export function.

## Saving and loading data for an individual input mode (import, export)

To save or load waveforms for individual input modes, use the import and export function. Import is used to load data, while export is used to save data. Both are accessible from the File menu.

Depending on the input mode, you can load data saved by a recorder or power meter. To load created data into a recorder, use the export function.

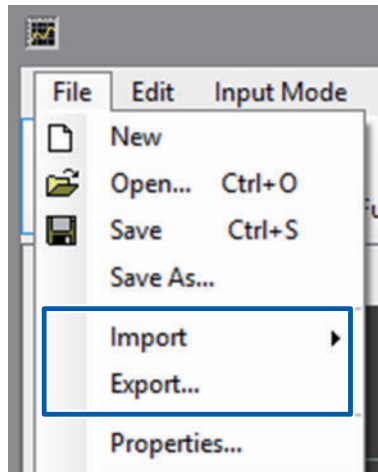

The following table lists the file types that are supported by each input mode:

Input mode	Ext.	Description	Format	SF8000		Recorder	
				Export (Save)	Import (Load)	Save	Load
Arb. Wave Input	WFG	Arbitrary waveform data	Binary	✓	✓	✓	✓
	TFG		Text	✓	✓	-	✓
	MEM	8847, MR8847, MR8827, MR8740, MR8741 waveform file*	Binary	-	✓	✓	✓
	CSV		Text	-	✓	✓	-
	EVT		PW3198 event file	Binary	-	✓	-
Function Input	WFG	Arbitrary waveform data	Binary	✓	✓	✓	✓
	TFG		Text	✓	-	-	✓
	PGM	Function formula data	Text	✓	✓	-	-
	PRG	Function formula data (Legacy format)	Text	-	✓	-	-
Step Input	WFG	Arbitrary waveform data	Binary	✓	✓	✓	✓
	TFG		Text	✓	-	-	✓
	STP	Step settings data	Text	✓	✓	-	-
Interpolation	WFG	Arbitrary waveforms data	Binary	✓	✓	✓	✓
	TFG		Text	✓	-	-	✓
	STP	Dot data	Text	✓	✓	-	-
Pulse Pattern	PLS	Pulse pattern data	Binary	✓	✓	✓	✓
	CSV		Text	✓	✓	-	-

\*Waveform data measured at a sampling speed of greater than 500 ns/S cannot be imported.

# 14 Specifications

## 14.1 U8793 Arbitrary Waveform Generator Unit

### General specifications

<b>Operating environment</b>	As per Memory HiCorder in which U8793 is installed
<b>Operating temperature and humidity</b>	As per Memory HiCorder in which U8793 is installed
<b>Storage temperature and humidity</b>	-20°C to 50°C (-4.0°F to 122°F), 80% RH or less (no condensation)
<b>Standards</b>	Safety: EN61010 EMC: EN61326 Class A
<b>Dielectric strength</b>	350 V AC (sensed current: 1 mA) (between individual output channels and enclosure/external I/O terminals as well as between individual output channels)
<b>Dimensions</b>	Approx. 106W × 19.8H × 196.5D mm (4.17" W × 0.78"H × 7.74"D) (excluding protrusions)
<b>Mass</b>	Approx. 250 g (8.8 oz.)
<b>Product warranty period</b>	3 years
<b>Options</b>	L9795-01 Connection Cable (terminal type: SMB terminal/mini-alligator clip) L9795-02 Connection Cable (terminal type: SMB terminal/BNC terminal)

### Output specifications

#### Basic specifications (common for both FG function and arbitrary waveform generation function)

<b>Conditions of guaranteed accuracy</b>	Guaranteed accuracy period: 1 year Guaranteed accuracy period after adjustment made by Hioki: 1 year Temperature and humidity for guaranteed accuracy: 23°C ±5°C (73°F ±9°F), 80% RH or less Warm-up time: At least 30 min. Power supply frequency range for Memory HiCorder in which U8793 is installed: 50 Hz/60 Hz ±2 Hz
<b>Number of output channels</b>	2 channels
<b>Output terminals</b>	SMB terminals
<b>Output type</b>	Unbalanced output (floating)
<b>Maximum rated voltage to earth</b>	33 V AC rms or 70 V DC (between individual output channels and enclosure/external I/O terminals as well as between individual output channels) Anticipated transient overvoltage: 330 V
<b>Maximum output voltage</b>	-10 V to 15 V
<b>Amplitude setting range</b>	0 V p-p to 20 V p-p (setting resolution: 1 mV)
<b>DC offset setting range</b>	-10 V to 15 V (setting resolution: 1 mV)
<b>Output impedance</b>	1 Ω or less

<b>Maximum output current</b>	±10 mA (per channel)
<b>Allowable load resistance</b>	1.5 kΩ or greater
<b>Output format</b>	Waveform output/open/short

### FG function specifications

<b>Output waveform</b>	Sine wave, rectangular wave, pulse wave (variable duty ratio), triangular wave, ramp wave, DC
<b>Output frequency range</b>	0 Hz to 100 kHz (setting resolution: 10 mHz)
<b>Output frequency accuracy</b>	±0.015% of setting
<b>DC output accuracy</b>	±0.05% of setting ±10 mV
<b>DC output temperature characteristics</b>	(±0.005% of setting ±1 mV)/°C
<b>Amplitude accuracy</b>	±0.5% of setting ±10 mV p-p (not lower than 10 mHz but not higher 10 kHz) ±0.8% of setting ±10 mV p-p (higher than 10 kHz but not higher than 50 kHz) ±1.0% of setting ±10 mV p-p (higher than 50 kHz but not higher than 100 kHz)
<b>Amplitude temperature characteristics</b>	(±0.05% of setting ±1 mV p-p)/°C
<b>DC offset accuracy</b>	±0.5% of setting ±10 mV
<b>DC offset temperature characteristics</b>	(±0.05% of setting ±1 mV)/°C
<b>Phase difference setting range</b>	-360° to 360° (setting resolution: 0.1°)
<b>Jitter</b>	Within 50 ns p-p (rectangular waves, pulse waves, triangular waves, ramp waves)
<b>Pulse wave duty ratio setting range</b>	0.1% to 99.9% (setting resolution: 0.1%) Valid with a pulse width of 500 ns or greater
<b>Pulse wave duty ratio accuracy</b>	±0.1% of period (not lower than 10 mHz but not higher than 5 kHz) ±0.5% of period (higher than 5 kHz but not higher than 20 kHz) ±1.0% of period (higher than 20 kHz but not higher than 100 kHz)

### Arbitrary waveform generation function specifications

<b>Output waveform</b>	Waveforms measured with the 8847, MR8847, MR8847A, MR8827, MR8740, or MR8741 Memory HiCorder (Logic waveforms are not supported.) Waveforms measured with the PW3198 Power Quality Analyzer (via SF8000) Waveforms saved by the 7075 Waveform Generator (via SF8000) Waveforms created in CSV format (via SF8000) Waveforms created with the SF8000 Waveform Maker
<b>Voltage axis resolution</b>	16 bits
<b>Waveform memory capacity</b>	256 kW/channel × 8 blocks
<b>Low-pass filter</b>	2nd-order LPF, 50 Hz to 1 MHz (14 steps in 1-2-5 progression)
<b>D/A refresh rate</b>	Max. 2 MHz (setting resolution: 10 mHz)
<b>Clock frequency accuracy</b>	±150 ppm

<b>Clock frequency jitter</b>	Within 50 ns p-p
<b>Delay</b>	-250,000 to 250,000 (settable in increments of 1 data point)
<b>Loop count</b>	1 to 50,000 or $\infty$

## Sweep function specifications

<b>Sweep waveform</b>	Non-DC FG waveforms, arbitrary waveforms
<b>Sweep form</b>	Linear
<b>Sweep targets</b>	FG waveforms: Frequency, amplitude, offset, duty ratio (pulse waves only) (Simultaneous sweeping of frequency, amplitude, and offset) Arbitrary waveforms: Clock frequency, amplitude, offset (Simultaneous sweeping of clock frequency, amplitude, and offset)
<b>Sweep time setting range</b>	10 $\mu$ s to 1000 s (setting resolution: 10 $\mu$ s)

## Program functional specifications

<b>Sequence length</b>	Output by connecting up to 128 steps
<b>Step control</b>	Ability to set an FG waveform, sweep waveform, or arbitrary waveform for each step Ability to set the number of loops (for sweep waveforms) or output time (for FG and arbitrary waveforms) for each step
<b>Hold setting</b>	ON/OFF setting for each step
<b>Output time setting range</b>	10 $\mu$ s to 1000 s (for FG and arbitrary waveforms)
<b>Step loop count setting range</b>	1 to 1,000 (for sweep waveforms)
<b>Overall loop count setting range</b>	1 to 50,000 or $\infty$
<b>Monitor function</b>	Display of step number being executed, step loop count, and overall loop count

## Other specifications

<b>Channel synchronization</b>	Ability to set the phase between channels on the same module (unit) and between modules (units)
<b>Self-test function</b>	Ability to monitor output voltage value Monitor resolution: 10 mV Monitor accuracy: $\pm 3.0\%$ f.s. (f.s. = 15 V)
<b>Output start/stop</b>	By operating key on the Memory HiCorder or applying a signal to the unit's external control terminal
<b>External input</b>	Cancel hold and transition to next step on LOW-level signal input from an external source while using the program function. Control voltage level: 3.5 V to 5.0 V (HIGH level), 0 V to 0.8 V (LOW level) Response pulse width: 100 $\mu$ s or greater (LOW level)
<b>External output</b>	Output during waveform output Output format: Open-drain output (with 5 V voltage output, active low) Output voltage level: 4.0 V to 5.0 V (HIGH level), 0 V to 0.5 V (LOW level) Maximum switching capacity: 5 V to 30 V DC, 50 mA
<b>External I/O terminals</b>	Push-button type terminal block
<b>Waveform output indicator</b>	Red LED on during waveform output and off when output is off

## 14.2 MR8790 Waveform Generator Unit

Accuracy figures assume installation in a Memory HiCorder and operation after a 30-minute warm-up period at 23°C ±5°C (73°F ±9°F) and 80% RH (no condensation).

### General specifications

<b>Product warranty period</b>	3 years
<b>Guaranteed accuracy period</b>	1 year
<b>Guaranteed accuracy period after adjustment made by Hioki</b>	1 year
<b>Number of output channels</b>	4 channels (all channels isolated from each other and from the enclosure and outputs)
<b>Self-test function</b>	Included (with voltage and current monitor)
<b>Voltage and current monitor function (switchable)</b>	Resolution: 5 µA (current monitor) 10 mV (voltage monitor) Monitor accuracy: ±3.0% f.s. (f.s. = 10 V [voltage monitor] or 5 mA [current monitor])
<b>Maximum output current</b>	±5 mA
<b>Allowable load resistance</b>	2 kΩ or greater
<b>Output terminals</b>	SMB terminals
<b>Output configuration</b>	Waveform output/open/short circuit
<b>Output relay switching time</b>	5 ms or less
<b>Output protection</b>	Output current limited to 40 mA (when output is shorted)
<b>Maximum rated voltage to earth</b>	33 V AC rms or 70 V DC (between individual output channels and enclosure as well as between individual output channels) Anticipated transient overvoltage: 330 V
<b>Dielectric strength</b>	350 V AC (sensed current: 1 mA) (between individual output channels and enclosure as well as between individual output channels)
<b>Operating temperature and humidity</b>	As per Memory HiCorder into which the MR8790 is installed
<b>Operating environment</b>	As per Memory HiCorder into which the MR8790 is installed
<b>Storage temperature and humidity</b>	Temperature: -20°C to 50°C (-4.0°F to 122°F) Humidity: 90% RH or less (no condensation)
<b>Dimensions</b>	Approx. 106W × 19.8H × 196.5D mm (4.17"W × 0.78"H × 7.74"D) (excluding protrusions)
<b>Mass</b>	Approx. 230 g (8.1 oz.)
<b>Standards</b>	Safety: EN61010 EMC: EN61326 Class A
<b>Effect of radiated radio-frequency electromagnetic field</b>	±3% f.s. (max.) at 3 V/m (f.s. = 10 V)

<b>Effect of conducted radio-frequency electromagnetic field</b>	±1% f.s. (max.) at 3 V (f.s. = 10 V)
<b>Options</b>	L9795-01 Connection Cable (terminal type: SMB terminal/mini-alligator clip) L9795-02 Connection Cable (terminal type: SMB terminal/BNC terminal)

## Voltage output specifications

<b>Maximum output voltage</b>	±10 V
<b>Resolution</b>	16 bits
<b>Output frequencies</b>	Output frequencies: DC, 0 Hz to 20 kHz (sine wave) Setting resolution: 1 Hz Frequency accuracy: ±0.01% of setting
<b>Amplitude</b>	Setting range: 0 V p-p to 20 V p-p Setting resolution: 1 mV Amplitude accuracy: ±0.25% of setting ±2 mV p-p (not lower than 1 Hz but not higher than 10 kHz) ±0.6% of setting ±2 mV p-p (higher than 10 kHz but not higher than 20 kHz)
<b>DC offset</b>	Setting range: -10 V to 10 V Peak value including amplitude and DC offset is limited to ±10 V. Setting resolution: 1 mV Offset accuracy: ±3 mV
<b>DC output</b>	Output accuracy: ±0.6 mV

## 14.3 MR8791 Pulse Generator Unit

### General specifications

<b>Temperature and humidity for guaranteed accuracy</b>	23°C ±5°C (73°F ±9°F), 80% RH or less (no condensation) (when installed in Memory HiCorder)
<b>Guaranteed accuracy period</b>	1 year
<b>Product warranty period</b>	3 years
<b>Operating temperature and humidity</b>	As per Memory HiCorder in which MR8791 is installed
<b>Operating environment</b>	As per Memory HiCorder in which MR8791 is installed
<b>Storage temperature and humidity</b>	-20°C to 50°C (-4.0°F to 122°F), 90% RH or less (no condensation)
<b>Maximum rated voltage to earth</b>	33 V AC RMS or 70 V DC (between output channels and enclosure) Anticipated transient overvoltage: 330 V
<b>Dielectric strength</b>	350 V AC (sensed current: 1 mA) (between output channels and enclosure) (between output units)
<b>Dimensions</b>	Approx. 106W × 19.8H × 196.5D mm (4.17"W × 0.78"H × 7.74"D) (excluding protrusions)
<b>Mass</b>	Approx. 230 g (8.1 oz.)
<b>Number of output channels</b>	8 (output channels and enclosure isolated; output units isolated) (channels not isolated from each other [common GND]) (channels not isolated from output connector frame [common GND])
<b>Output mode 1</b>	Pattern output/pulse output (switched for all 8 channels at once)
<b>Output mode 2</b>	Logic output/open-collector output (set separately for each of 8 channels)
Logic output:	Output voltage level: 0 V to 5 V (HIGH level 3.8 V or greater, LOW level 0.8 V or less) Rated current: ±5 mA
Open-collector output:	Collector/emitter absolute maximum rated voltage: 50 V Overcurrent protection: 100 mA
<b>Output mode 3</b>	Output/open (=self-test) (switched for all 8 channels at once)
<b>Open-collector output definition (rising time [10% to 90%])</b>	5 μs (max.) (load capacity of 1000 pF, pull-up resistance of 1 kΩ)
<b>Self-test function</b>	Detected voltages: HIGH level 3.4 V or greater, LOW level 1.6 V or less
<b>Relay switching time</b>	5 ms or less (logic/open collector switching, output/open [self-test] switching)
<b>Standards</b>	Safety: EN61010 EMC: EN61326 Class A

## Pulse output specifications

<b>Output frequency</b>	Setting range: 0 Hz to 20 kHz (set separately for each of 8 channels) Setting resolution: 0.1 Hz Frequency accuracy: As per time axis accuracy of Memory HiCorder in which MR8791 is installed
<b>Duty</b>	Setting range: 0.1% to 99.9%, 0, 100% (DC) Setting resolution: 0.1% Duty accuracy: As per time axis accuracy of Memory HiCorder in which MR8791 is installed
<b>Minimum pulse width</b>	1 $\mu$ s

## Pattern output specifications

<b>Clock frequency</b>	Range: 0 Hz to 120 kHz (common to all 8 channels) Setting resolution: 10 Hz Frequency accuracy: As per time axis accuracy of Memory HiCorder in which MR8791 is installed
<b>Memory (patterns)</b>	2,048 words (16,384 bits = 2,048 words $\times$ 8 bits/word)

## Output connector specifications

10250-52A2PL: Sumitomo 3M (SCSI-2 connector) (Centronics half 50-pin female)

Pin	Signal	Pin	Signal
1	I_GND	26	I_GND
2	CH1	27	I_GND
3	CH2	28	I_GND
4	CH3	29	I_GND
5	CH4	30	I_GND
6	I_GND	31	I_GND
7	CH5	32	I_GND
8	CH6	33	I_GND
9	CH7	34	I_GND
10	CH8	35	I_GND
11	I_GND	36	I_GND
12	NC	37	I_GND
13	NC	38	I_GND
14	NC	39	I_GND
15	NC	40	I_GND
16	I_GND	41	I_GND
17	NC	42	I_GND
18	NC	43	I_GND
19	NC	44	I_GND
20	NC	45	I_GND
21	I_GND	46	I_GND
22	TEST2 (DIN03)	47	I_GND
23	TEST3 (DIN02)	48	I_GND
24	NC	49	I_GND
25	NC	50	I_GND
Frame	F_GND		

CH1 to CH8: Pulse output  
I\_GND: Isolation GND (isolation GND)  
F\_GND: Non-isolation GND (instrument GND)  
NC: No connection  
TESTn: Test pin (connection prohibited)

Recommended connection cable: KB-SHH2: Sanwa Supply (SCSI-2 connector) (Centronics half 50-pin male)

# 15 Maintenance and Service

## 15.1 Cleaning the Unit

### CAUTION



Clean the unit regularly to keep dust from obstructing its air vents. If the vents become blocked, reduced cooling inside the unit may cause equipment damage or other issues..

#### Important

- To clean the unit, moisten a soft cloth with water or neutral detergent and lightly wipe it clean.
- Never use detergents or cleansers that contain benzene, alcohol, acetone, ether, ketones, paint thinner, or gasoline. Doing so may cause discoloration or deformation of shape of the unit.

## 15.2 Troubleshooting

### CAUTION



Do not attempt to modify, disassemble, or repair the unit yourself. Doing so may result in burns, electric shock, or other bodily injury.

If you believe your device may be malfunctioning, review the information in “Before having your device repaired” and contact your authorized Hioki distributor or reseller.

### Before having your device repaired

Check the following if your device is behaving in an unexpected manner.

Symptom	What to check	Solution	Refer to
The device will not output a waveform.	<ul style="list-style-type: none"> <li>• Is output set to [ON]?</li> <li>• Is Generator Control set to [RUN]?</li> </ul>	The device will not output a waveform if output is set to [OFF], even if Generator Control is set to [RUN]. Set Generator Control to [RUN] and output to [ON].	p. 26 p. 57 p. 71
The output waveform's voltage values are odd.	<ul style="list-style-type: none"> <li>• Is the connection cable properly connected to the output terminal?</li> <li>• Is an offset being added? (FG waveforms)</li> <li>• Is the amplitude adjustment setting incorrect, or is an offset not being added? (Arbitrary waveforms)</li> <li>• Has the filter been properly configured? (Arbitrary waveform)</li> </ul>	<ul style="list-style-type: none"> <li>• Verify that the cable is properly connected to the output terminal.</li> <li>• Set the offset to 0 V.</li> <li>• Set amplitude adjustment to 1× and the offset to 0 V.</li> <li>• Set the filter to OFF or set the filter's cutoff frequency to an appropriate value.</li> </ul>	p. 12 p. 13 p. 23  p. 52 p. 53 p. 56
You are unable to register arbitrary waveform data.	Does the file have an extension that can be registered?	Files that can be registered have an extension of either “.wfg” or “.tfg.” (Pulse pattern files have an extension of “.pls.”)	p. 49
The output frequency of a arbitrary waveform registered from a measured waveform does not match the output frequency of the measured waveform.	Do the sampling frequency used during measurement and the clock frequency used when outputting the arbitrary waveform match?	Use the sampling frequency at measurement as the clock frequency.	p. 51
You are unable to import files with the SF8000 application.	<ul style="list-style-type: none"> <li>• Is the file compatible with the current input mode?</li> <li>• Is the file a waveform file that was measured at a sampling rate faster than 500 ns/S?</li> </ul>	<ul style="list-style-type: none"> <li>• Import a file that is compatible with the current input mode.</li> <li>• Use a waveform file that was measured at a sampling rate of 500 ns/S or less.</li> </ul>	p. 121
You don't know what is causing the issue.	Perform a system reset on the Memory HiCorder. All settings will revert to their factory defaults.		

## 15.3 Error Messages

### U8793 Arbitrary Waveform Generator Unit

Display no.	Message	Solution
111	No space to register arbitrary waveform data.	A maximum of eight arbitrary waveforms can be registered. Delete one or more arbitrary waveforms and then register the new waveform. (p. 46)

This section lists only those messages that pertain to the U8793. For other messages and associated solutions, see the Memory HiCorder's instruction manual.

### SF8000 Waveform Maker

Message	Solution
The application is already running.	The SF8000 application is already running. Only one instance of the SF8000 application can run at a time.
Insufficient privileges to access the file <file>.	Check the file's access settings.
The number of steps exceeds tolerances.	The maximum number of steps that can be configured (100) was exceeded. Add new steps after deleting steps that are no longer necessary.
The number of pulse pattern data exceeds tolerances.	The maximum number of pulse pattern settings (2048) was exceeded. Add new pulse pattern settings after deleting data that is no longer necessary.
Unable to create the file <file>.	Check the amount of available space on the destination media as well as the file access settings.
Unable to load the file <file>.	Check whether the file is corrupt, or whether the file format is supported by the SF8000 application.
Unable to load the folder <folder>.	The necessary file could not be found in the EVT folder. Verify that all files are present.
Communications will be interrupted. Proceed?	You attempted to close the data transfer screen while communications were still in progress. Closing the screen will interrupt communications.
The work state has been updated. Save?	The changes have not been applied to the file. To apply them, save the file.
Unable to connect to Memory HiCorder.	Verify that the cable is connected firmly and that the LAN settings have been configured properly.
Unable to communicate with Memory HiCorder or unable to register additional data.	If the Memory HiCorder is performing measurement, end measurement or wait for measurement to complete. If the maximum number of data points that can be registered has been reached, delete unnecessary data before registering new data.



# Index

## A

Amplitude.....	22
Arbitrary Waveform.....	45
Clock Frequency.....	51
Delay.....	54
Filter.....	56, 66

## C

Channel.....	16
Copying and Pasting.....	16
Clock Frequency.....	
Pattern Mode.....	38
Connecting Cables.....	12

## D

Duty.....	24
-----------	----

## E

External Input.....	82
External Output.....	83
External Output Terminal.....	8, 14, 81

## F

FG Waveform.....	17
Frequency.....	21

## I

Installation.....	5
Installing the unit.....	11

## M

Mode.....	29
MR8790.....	126
Voltage Output Specifications.....	127
MR8791.....	128
Output Connector.....	129
Pattern Output Specifications.....	129
Pulse Output Specifications.....	129

## O

Offset.....	23
Output.....	
Pattern Mode.....	39
Output Connector.....	8
Output Indicators.....	8
Output Terminals.....	13

## P

Pattern Mode.....	34
Output Type.....	34
Pattern to Use.....	35
Phase.....	25
Program.....	59
Overall Number of Loops.....	65
Program Settings Screen.....	59
Saving Edited Program.....	67
Program Progress.....	
Program.....	68
Pulse.....	29
Pulse Mode.....	30
Duty.....	31
Frequency.....	30
Output.....	33
Output Type.....	32

## R

Removing the unit.....	11
------------------------	----

## S

Self-test Function.....	77
Setting Output When Measurement Completes.....	
Signal.....	70
Signal.....	69
Control Method.....	69
Signal Output Status.....	71
Signal Generation Settings Screen (Generator Screen).....	15
Specifications.....	123
Sweep.....	41
End Value.....	43
Start Value.....	42
Sweep Time.....	44

## T

Tenkey (numeric input).....	19
Troubleshooting.....	132, 133

## U

U8793.....	
General Specifications.....	123, 126, 128
Other Specifications.....	125
Output Specifications.....	123
Program Functional Specifications.....	125
Sweep Function Specifications.....	125
Up-down (arrow key input).....	18

**W**

---

Waveform Type..... 20



# HIOKI

<http://www.hioki.com>



**Our regional  
contact  
information**

## **HEADQUARTERS**

81 Koizumi, Ueda, Nagano 386-1192 Japan

## **HIOKI USA CORPORATION**

<http://www.hiokiusa.com/> [hioki@hiokiusa.com](mailto:hioki@hiokiusa.com)

## **HIOKI (Shanghai) SALES & TRADING CO., LTD.**

<http://www.hioki.cn/> [info@hioki.com.cn](mailto:info@hioki.com.cn)

## **HIOKI SINGAPORE PTE.LTD.**

[www.hioki.com.sg/](http://www.hioki.com.sg/) [info-sg@hioki.com.sg](mailto:info-sg@hioki.com.sg)  
[info-indo@hioki.com.sg](mailto:info-indo@hioki.com.sg) (Indonesia)  
[info-thai@hioki.com.sg](mailto:info-thai@hioki.com.sg) (Thailand)  
[info-vn@hioki.com.sg](mailto:info-vn@hioki.com.sg) (Vietnam)

## **HIOKI KOREA CO., LTD.**

<http://www.hiokikorea.com/> [info-kr@hioki.co.jp](mailto:info-kr@hioki.co.jp)

## **HIOKI EUROPE GmbH**

<http://www.hioki.com/> [hioki@hioki.eu](mailto:hioki@hioki.eu)

## **Taiwan Representative Office**

<http://www.hioki.com/> [info-tw@hioki.com.tw](mailto:info-tw@hioki.com.tw)

## **MEA Representative Office**

<http://www.hioki.com/> [hioki@hiokimea.ae](mailto:hioki@hiokimea.ae)

1804EN

Edited and published by HIOKI E.E. CORPORATION

Printed in Japan

- CE declarations of conformity can be downloaded from our website.
- Contents subject to change without notice.
- This document contains copyrighted content.
- It is prohibited to copy, reproduce, or modify the content of this document without permission.
- Company names, product names, etc. mentioned in this document are trademarks or registered trademarks of their respective companies.